

ISOMOVE

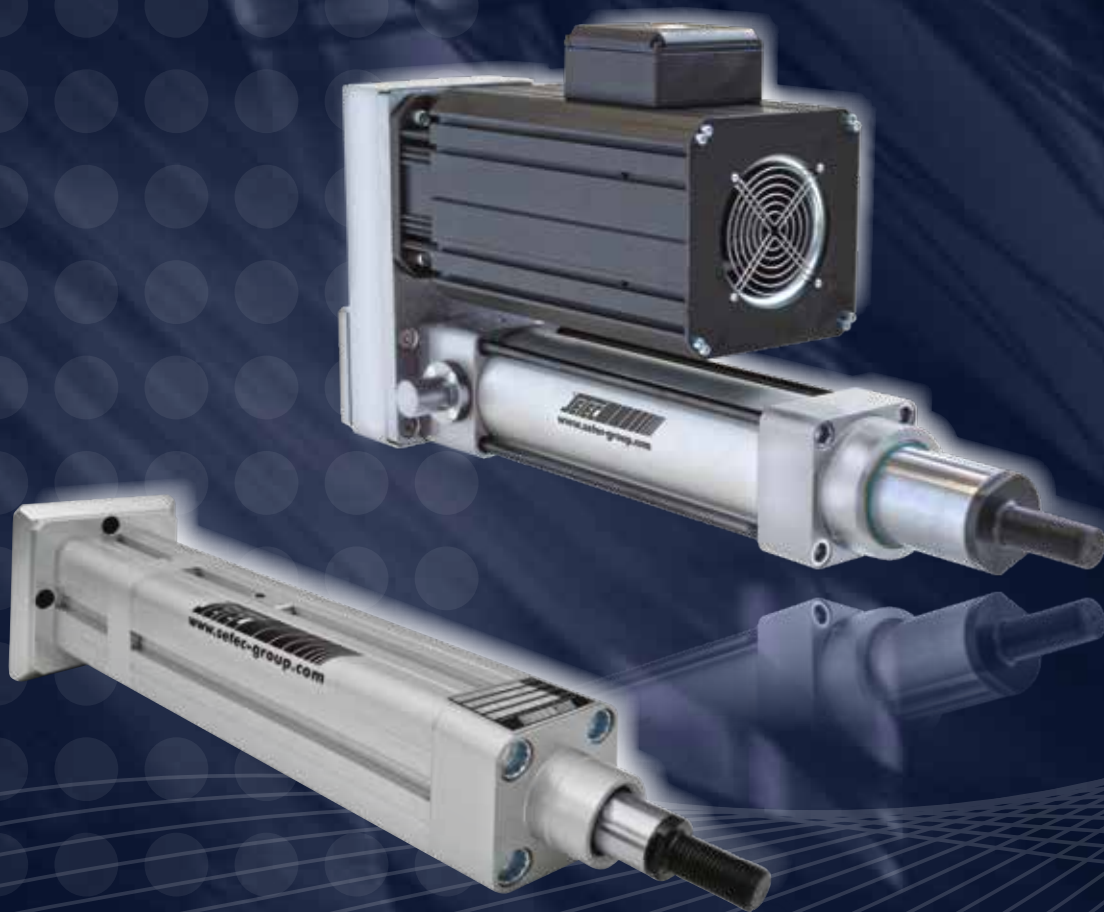

ATTUATORI LINEARI MECCANICI DI PRECISIONE PER ALTA DINAMICA
PRECISION MECHANICAL LINEAR ACTUATORS FOR HIGH DYNAMICS

[®]**JETEC**
COMPONENTS CONTROLS MOTION SYSTEMS

ISOMOVE-E the evolution
ISOMOVE-E the evolution

AVVERTENZE - RESPONSABILITÀ

- **L'ATTUATORE MECCANICO LINEARE ISOMOVE È UN COMPONENTE DI MACCHINA, ESSO STESSO NON SVOLGE ALCUNA FUNZIONE PROPRIA AUTONOMAMENTE, PERTANTO NON È DA CONSIDERARSI NÉ QUASI-MACCHINA NÉ MACCHINA.**

Esso deve essere integrato all'interno di una macchina o di una quasi-macchina nel rispetto delle Normative, delle Direttive e delle Leggi in vigore nel Paese del costruttore della macchina/impianto, a carico e cura di quest'ultimo.

- I contenuti del presente documento e di tutte le informazioni correlate fornite da SETEC S.p.A. e/o SERVOSYSTEM s.r.l. e dai Distributori autorizzati costituiscono opzioni di prodotti che dovranno essere analizzati dai Clienti/Utenti terzi esterni dotati di competenze tecniche.
- Il Cliente/Utente, attraverso suoi processi di analisi e verifica, si assume la responsabilità assoluta per la scelta finale del componente/sottosistema e si adopera per garantire che vengano soddisfatti tutti i requisiti dell'applicazione in oggetto relativamente a prestazioni richieste, attività di manutenzione, resistenze strutturali, corretta installazione e sicurezze della stessa.
- Il Cliente/Utente ha l'obbligo di fornire tutte le informazioni relative all'applicazione in oggetto a SETEC S.p.A., alle sue consociate ed ai suoi Distributori autorizzati e di attenersi agli standard di settore; inoltre deve seguire le informazioni fornite da SETEC S.p.A., dalle sue consociate e dai suoi Distributori autorizzati attraverso questo od altri documenti inerenti forniti.
- Il Cliente/Utente ha la responsabilità di verificare che tali informazioni e specifiche tecniche di prodotto siano corrette e quindi accettabili per la sua applicazione.
- IL GRUPPO SETEC SI RISERVA IL DIRITTO DI APPORTARE AL PRESENTE DOCUMENTO TUTTE LE MODIFICHE CHE SI RENDERANNO NECESSARIE SENZA ALCUN PREAVVISO E NON SI ASSUME NESSUNA RESPONSABILITÀ PER ERRATA INTERPRETAZIONE DELLO STESSO.

WARNINGS - LIABILITIES

- **THE MECHANICAL LINEAR ACTUATOR ISOMOVE IS A PURE MACHINE COMPONENT, IT DOESN'T CARRY OUT ANY FUNCTION AUTONOMOUSLY, THUS IT IS NOT A MACHINE OR A HEMI-MACHINE ITSELF.**

The actuator must be integrated into the machine or into the hemi-machine according to the Standards, the Directives and the Laws of the Country to whom the Manufacturer of the machine belongs. The Manufacturer must do it at its expenses and with great care.

- All the contents of this catalogue and all the separate information related to it supplied by SETEC S.p.A. and/or SERVOSYSTEM s.r.l. and by the Authorized Distributors are only possible options of products which will then have to be analysed very carefully by the Customers/Users with a deep technical knowledge.
- The Customer/User, through his analysis and check processes, is entirely liable for his final selection of the component/sub-assembly. He will act in order to have all the service requirements of the application met, considering the requested performances, the needed maintenance activities, the structural resistance of the parts of the machine connected to the actuator. He will take care about the proper installation of the actuator itself and of the safety devices related to it.
- The Customer/User is obliged to provide SETEC / SERVOSYSTEM / ANY AUTHORIZED DISTRIBUTOR with all the important and decisive information about the application under analysis and must respect all the Standards of his market. Furthermore the Customer/User must properly follow all the information supplied by SETEC / SERVOSYSTEM / ANY AUTHORIZED DISTRIBUTOR by this or other related documents.
- The Customer/User is liable for checking that all the supplied information and the technical specification of the products herein included are valid for his machine.
- SETEC GROUP RESERVES THE RIGHT TO MAKE ALL THE NECESSARY CHANGES/MODIFICATIONS TO THIS DOCUMENT WITHOUT ANY NOTICE. SETEC GROUP WILL NOT BE LIABLE FOR ANY WRONG UNDERSTANDING BY THE CUSTOMER/USER.



ISOMOVE - E: L'evoluzione

ISOMOVE - E: The evolution

Presentazione generale

General description

Il GRUPPO SETEC da OLTRE 40 ANNI progetta e produce una ampia gamma di attuatori lineari industriali elettromeccanici per tutti i settori dell'industria e dell'automazione in generale.

Decine di migliaia di nostri attuatori, sia STANDARD che SPECIALI sono installati sul campo, nei più svariati settori applicativi:

- SIDERURGIA
- LEGNO
- MARMO
- PIETRA
- PACKAGING
- STAMPA
- CONVERTING
- MACCHINE UTENSILI
- VETRO
- TUBO
- FILO METALLICO
- PLASTICA
- SALDATURA
- ROBOTICA
- SOLARE
- HANDLING

Gli attuatori lineari meccanici di precisione per alta dinamica ISOMOVE-E costituiscono la naturale EVOLUZIONE della prima serie, in produzione ormai da più di 20 ANNI, beneficiando quindi di tutta l'esperienza progettuale, produttiva ed applicativa su tutti i principali mercati mondiali ed in tutti i settori industriali più importanti della costruzione di macchine ed impianti.

SETEC GROUP has been designing and manufacturing for MORE THAN 40 YEARS a wide range of industrial electromechanical linear actuators for all industry and automation markets.

Many thousands of our actuators, both STANDARD and SPECIAL ones, are working in the many different industrial sectors:

- STEEL
- WOOD
- MARBLE
- STONE
- PACKAGING
- PRINTING
- CONVERTING
- MACHINE TOOLS
- GLASS
- PIPING
- METAL WIRE
- PLASTICS
- WELDING
- ROBOTICS
- SOLAR PANELS
- HANDLING

Precision mechanical linear actuators for high dynamics ISOMOVE-E are the natural EVOLUTION of the first series, produced for more than 20 YEARS; they thus have the great benefit of our long experience in conceiving, manufacturing and using them worldwide in the most demanding machine builders sectors.

La particolare cura realizzativa dei particolari fondamentali per garantire tolleranze dimensionali, di forma e di posizione molto strette e le soluzioni progettuali adottate per ottenere un assieme con linearità e concentricità degli elementi in movimento molto buone fanno sì che essi sono il miglior prodotto per le applicazioni di automazione dove sono richieste ALTE DINAMICHE ed ELEVATE PRECISIONI.

I nostri PRINCIPALI VANTAGGI sono:

- TENSIONAMENTO CINGHIA REGOLABILE
- ELEVATA PERSONALIZZAZIONE possibile
- ELEVATA DENSITÀ DI FORZE
- GRANDI VELOCITÀ LINEARI
- COMPORTAMENTO per ALTA DINAMICA
- ELEVATA PRECISIONE
- FUNZIONAMENTO IN SERVIZIO CONTINUO
- ELEVATA RIGIDEZZA ASSIALE
- CONTROLLABILITÀ tramite SERVOAZIONAMENTI
- PROGRAMMABILITÀ tramite PLC / CONTROLLI ASSE
- NUMEROSE VERSIONI STANDARD disponibili

We take extreme care to make all the parts in order to get very tight dimensional, position and form tolerances.

All this together with innovative design solutions allow us to reach very good linearity and concentricity values of the assembled unit moving parts, thus obtaining the best product for HIGH DYNAMICS and HIGH ACCURACIES in automation applications.

Our MAIN ADVANTAGES are:

- ADJUSTABLE BELT TENSIONING
- HIGH CUSTOMIZATION possible
- HIGH FORCE DENSITY
- HIGH OUTPUT LINEAR SPEED
- SUITABLE for HIGH DYNAMICS BEHAVIOUR
- HIGH ACCURACY
- CONTINUOUS DUTY CYCLE possible
- HIGH AXIAL STIFFNESS
- CONTROLLABILITY by SERVODRIVES
- PROGRAMMABLE by PLC / AXIS CONTROLS
- MANY STANDARD VERSIONS AVAILABLE

Il nuovo elemento costitutivo dell'attuatore è il MODULO BASE:

The first new element of the actuator is the BASIC MODULE:

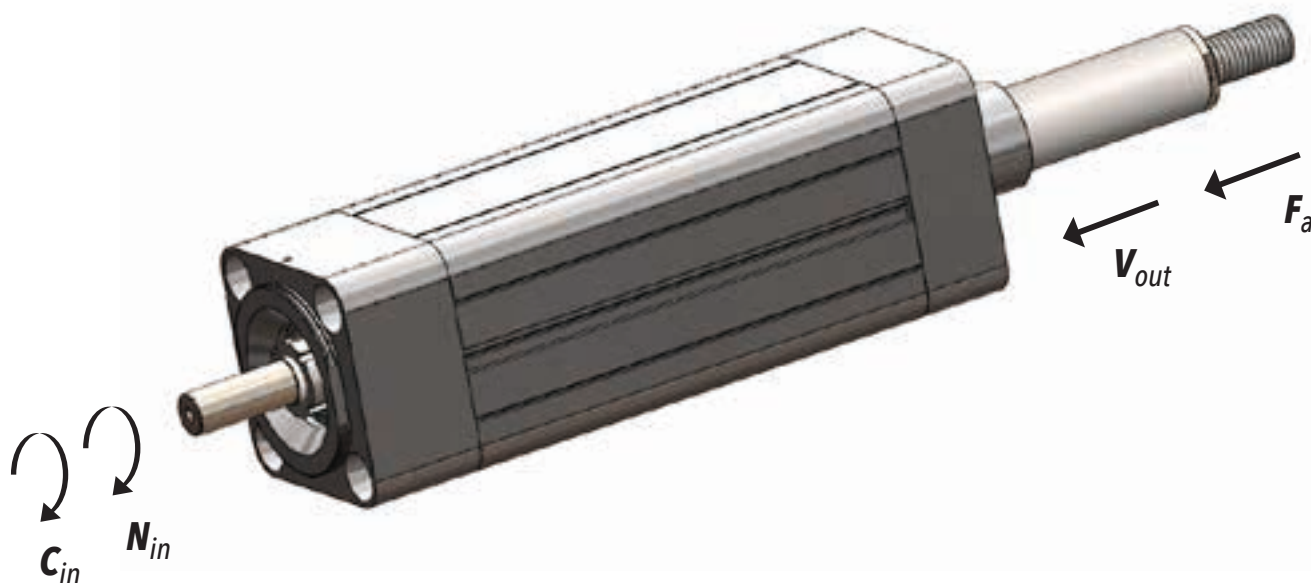

MODULO BASE
BASIC MODULE

I particolari costitutivi fondamentali del
MODULO BASE sono:

BASIC MODULE main parts are as follows:

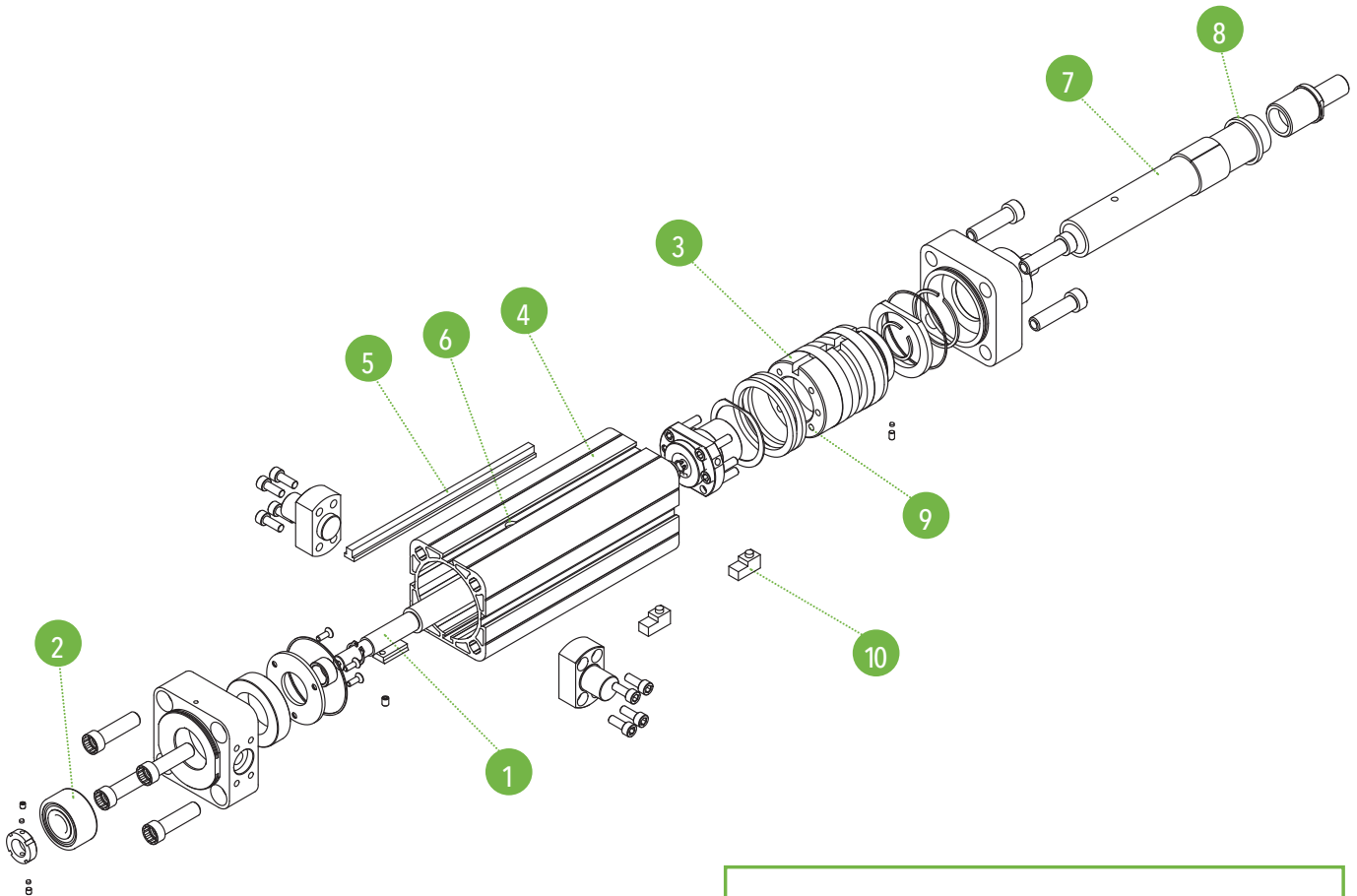

- | | | |
|----|---------------------|----------------------|
| 1 | vite a sfere | ballscrew |
| 2 | cuscinetto a sfera | ballbearing |
| 3 | pistone | piston |
| 4 | camicia | outer profile |
| 5 | asta antirotazione | antirotation device |
| 6 | foro lubrificazione | lubrication hole |
| 7 | stelo cromato | chrome push/pull rod |
| 8 | guarnizione | seal |
| 9 | magnete | magnet |
| 10 | sensore reed | reed sensor |

Per costruire, misurare e testare i nostri prodotti ci avvaliamo delle tecnologie più moderne e delle macchine ed attrezzature più sofisticate, spesso ricorrendo a soluzioni da noi progettate e costruite per avere esattamente quello che serve per garantire le migliori prestazioni:

We use the most modern technologies and the most sophisticated machines and equipments, often making them by ourselves to have exactly what is needed.

By all this we can make, measure and test all our products:



Stock semilavorati / Raw materials warehouse



Linea automatica taglio di precisione viti/cromati / Chrome tubes/screws precision cutting automated machine

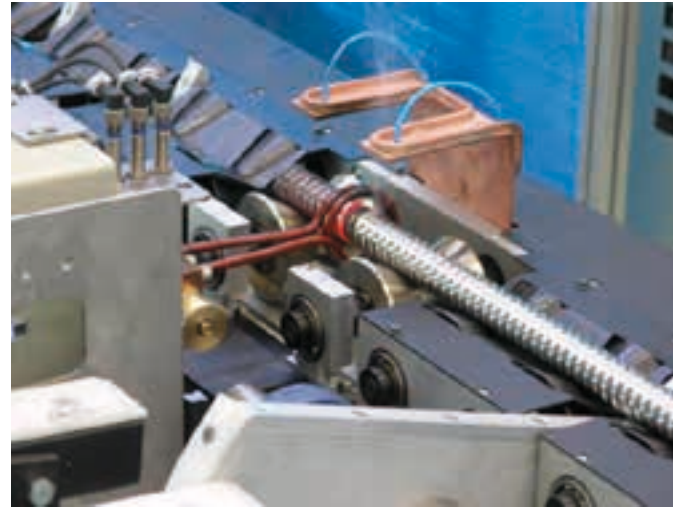

Rinvenimento ad induzione terminali / Journal ends induction annealing



Raddrizzatura di precisione / Precision straightening



Lavorazione particolari su centro CNC /
Mechanical parts machining on CNC milling machine



Lavorazione terminali viti / tubi cromati /
Chrome tubes/screws journal ends machinings





Sala metrologica /
Measurement room

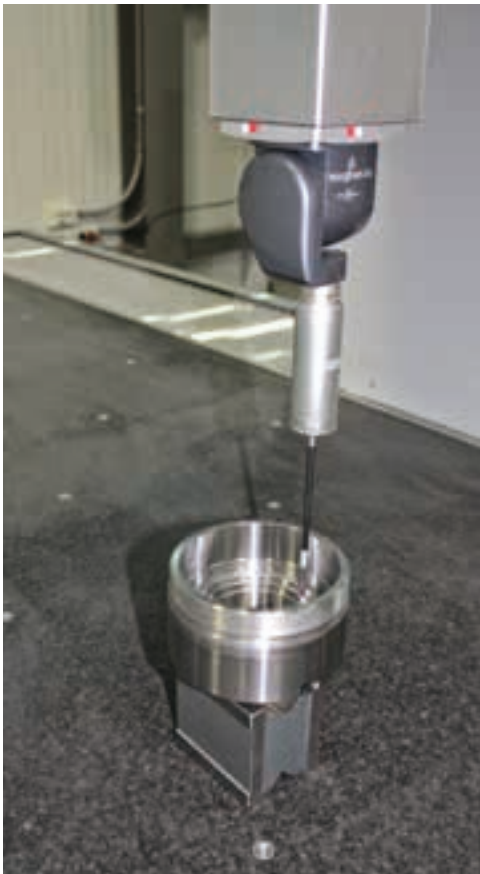



Controllo precarico assieme vite - madrevite /
Ball screw preload torque measurement bench



Area test / Testing area





Magazzino automatico /
Automated warehouse

Area test / Testing area



Campi di impiego

Field of applications

MANIPOLAZIONE / HANDLING

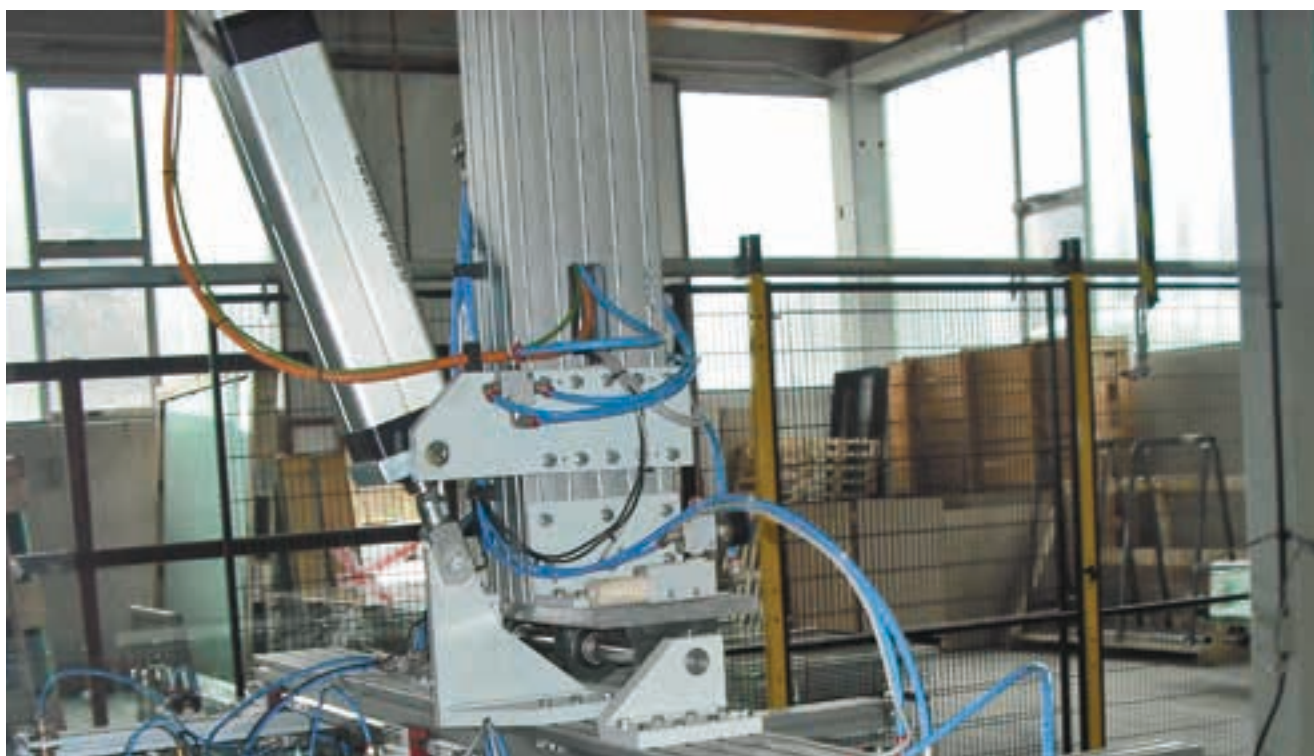

Ribaltatore lastre in vetro / Glass panel tilter

SIMULATORI / SIMULATORS



Simulatore di volo / Flight simulator



Campi di impiego

Field of applications

PLASTICA / PLASTICS



Macchine soffiaggio plastica / Blow moulding machines

Campi di impiego

Field of applications

ALIMENTARI / BEVERAGE



Macchina riempimento con dosatrice volumetrica / Filling machines by metering volumetric system

LOGISTICA / LOGISTICS



Carrello elevatore automatico /
Automated forklift truck

Campi di impiego

Field of applications

SISTEMI DI TRASPORTO / MATERIAL HANDLING



Sistema di tensionamento nastro / Band tensioning system

Campi di impiego

Field of applications

IMBALLAGGIO / PACKAGING

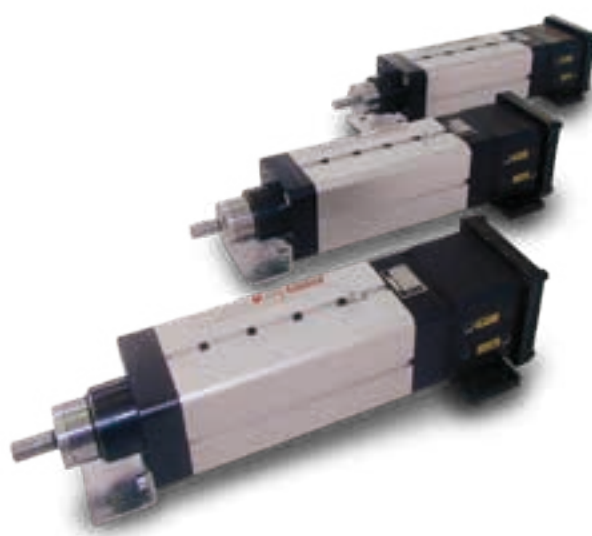

Incartonatrice /
Corrugated board packaging machine

SOLLEVAMENTO / LIFTING



Sistemi di
sollevamento /
Lifting equipments

Campi di impiego

Field of applications

VEICOLI / MOBILE



Azionamento freno veicoli senza uomo a bordo /
Brake driving of unmanned vehicle

CONVERTING / CONVERTING



Macchina converting
sistema taglia bobine /
Converting machinery
roller cutter system



Sinottico

Overview

IE 32 ÷ IE 100 XL

GRANDEZZA / SIZES			IE 32		IE 40		IE 50			IE 63		
P	PASSO VITE SCREW LEAD	[mm]	4	12	4	12	5	10	16	5	10	20
F_d	CARICO MASSIMO DINAMICO APPLICABILE MAX ADMISSIBLE DYNAMIC LOAD	[N]	3000	2000	3000	2000	4500	4500	4000	7500	7500	7500
V_{out,max}	VELOCITÀ MASSIMA IN USCITA MAX OUTPUT SPEED	[mm/sec]	200	600	200	600	250	500	800	250	500	1000
N_{in,max}	VELOCITÀ MASSIMA ROTAZIONE VITE A RICIRCOLO MAX BALLSCREW ROTATING INPUT SPEED	[rpm]	3000	3000	3000	3000	3000	3000	3000	3000	3000	3000
S_{max}	CORSA MASSIMA STANDARD* MAX STANDARD STROKE*	[mm]	500	500	500	500	700	700	700	800	800	800
a_{max}	ACCELERAZIONE MASSIMA IN USCITA MAX OUTPUT ACCELERATION	[m/sec ²]	1	2	1	2	1	2	2,5	1	2	3

* Per corse superiori, contattare il nostro servizio tecnico.
For longer strokes please contact our technical dept.

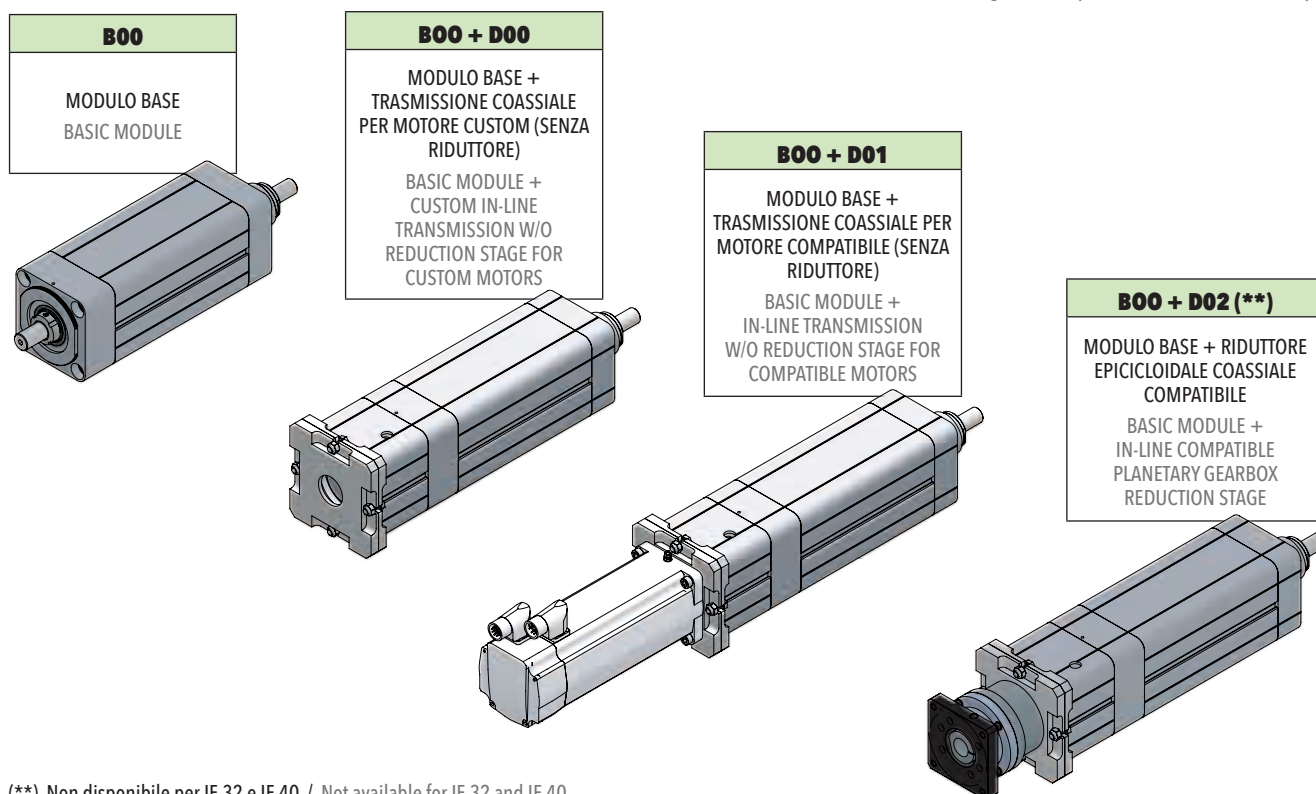

(**) Non disponibile per IE 32 e IE 40 / Not available for IE 32 and IE 40

Sinottico

Overview

IE 32 ÷ IE 100 XL

IE 80			IE 80HL			IE 100				IE 100HL				IE100XL
5	10	25	5	10	32	5	10	20	32	5	10	20	40	10
12000	12000	12000	21000	25000	18000	21000	25000	30000	16000	23000 23000*	30000 41000*	30000 40000*	30000 40000*	52000
250	500	1250	250	500	1600	250	500	1000	1600	208	416	833	1660	333
3000	3000	3000	3000	3000	3000	3000	3000	3000	3000	2496	2496	2496	2490	1998
1000	1000	1000	1000	1000	1000	1100	1100	1100	1100	1100	1100	1100	1100	1000
1	2	4	1	2	5	1	2	3	5	1	2	3	6	2

* Versione con tiranti / Tension rods version

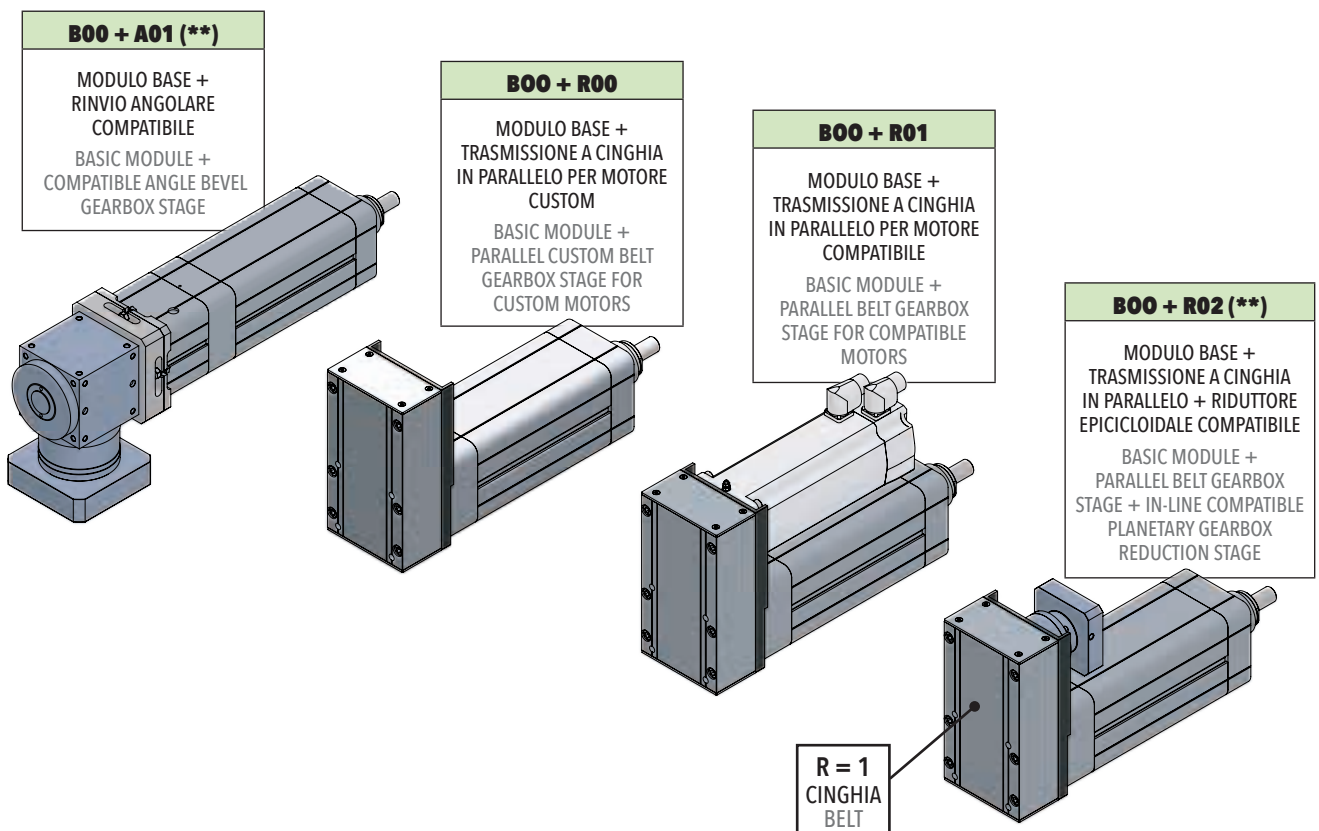

Sinottico

Overview

IE 125 / IE 160

GRANDEZZA / SIZES			IE 125		IE 160	
P	PASSO VITE SCREW LEAD	[mm]	10	20	10	20
F_d	CARICO MASSIMO DINAMICO APPLICABILE MAX ADMISSIBLE DYNAMIC LOAD	[N]	80000	80000	100000	120000
V_{out,max}	VELOCITÀ MASSIMA IN USCITA MAX OUTPUT SPEED	[mm/sec]	265	667	208	417
N_{in,max}	VELOCITÀ MASSIMA ROTAZIONE VITE A RICIRCOLO MAX BALLSCREW ROTATING INPUT SPEED	[rpm]	1590	2000	1248	1251
S_{max}	CORSA MASSIMA STANDARD* MAX STANDARD STROKE*	[mm]	1200	1200	1600	1600
a_{max}	ACCELERAZIONE MASSIMA IN USCITA MAX OUTPUT ACCELERATION	[m/sec ²]	2	3	2	3

* Per corse superiori, contattare il nostro servizio tecnico.
For longer strokes please contact our technical dpt.

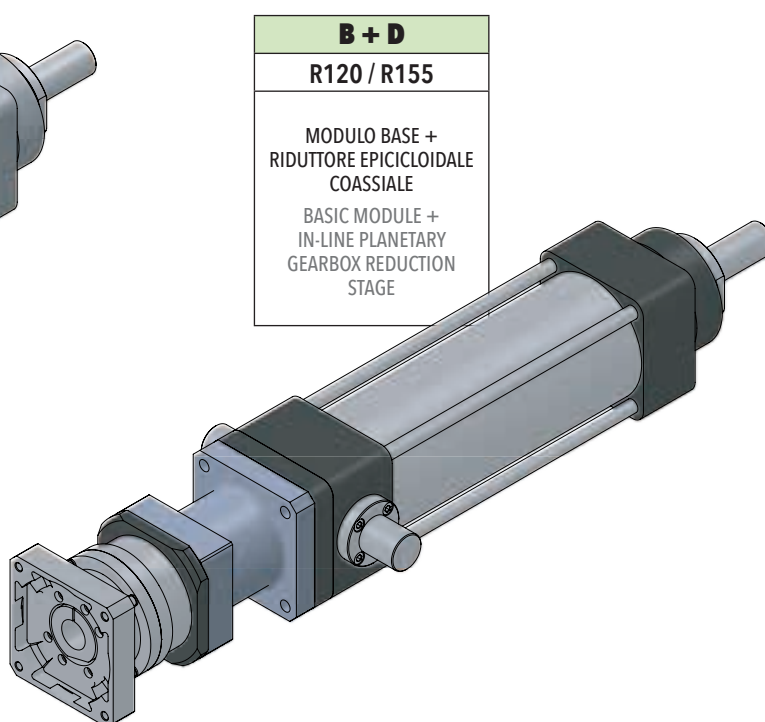
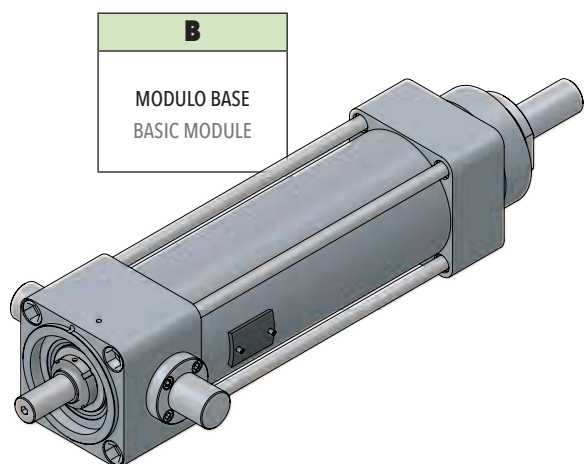

Sinottico

Overview

IE 125 / IE 160

B + A
A110 / A140 / A170* / A210*
MODULO BASE + RINVIO ANGOLARE BASIC MODULE + ANGLE BEVEL GEARBOX STAGE

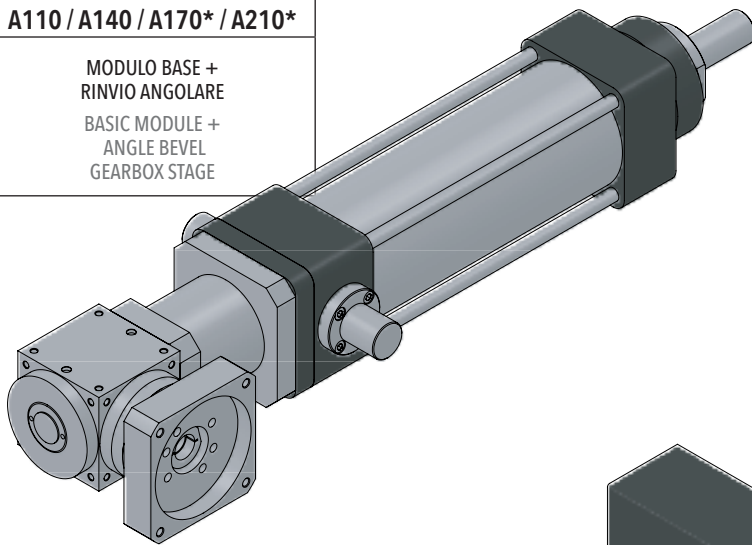

B + R
R00
MODULO BASE + TRASMISSIONE A CINGHIA IN PARALLELO PER MOTORE CUSTOM BASIC MODULE + PARALLEL FOR CUSTOM MOTORS BELT GEARBOX STAGE

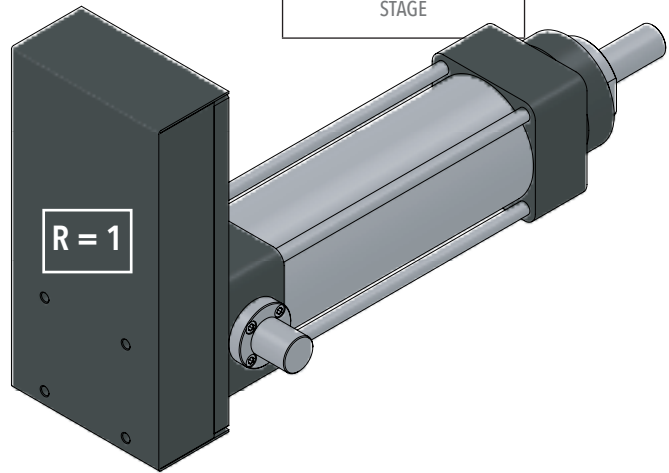

B + R
R120 / R155*
MODULO BASE + TRASMISSIONE A CINGHIA IN PARALLELO + RIDUTTORE EPICICLOIDALE BASIC MODULE + PARALLEL BELT GEARBOX STAGE + IN-LINE PLANETARY GEARBOX REDUCTION STAGE

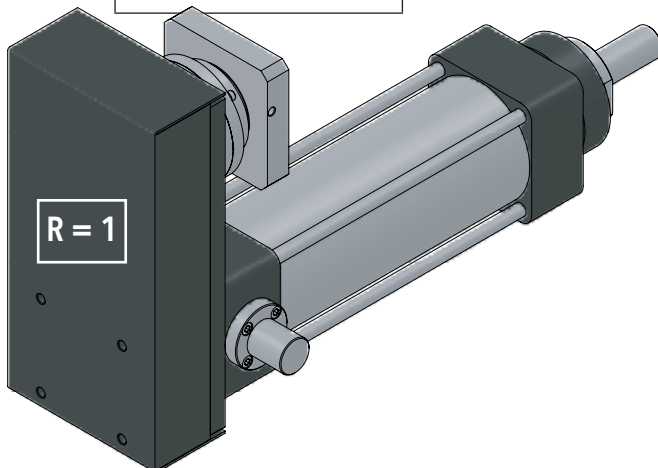

* Solo per IE 160 / Only for IE 160.

Sinottico

Overview

IE 240

GRANDEZZA / SIZES			IE 240
P	PASSO VITE SCREW LEAD	[mm]	25
F_d	CARICO MASSIMO DINAMICO APPLICABILE MAX ADMISSIBLE DYNAMIC LOAD	[N]	350000
V_{out,max}	VELOCITÀ MASSIMA IN USCITA MAX OUTPUT SPEED	[mm/sec]	417
N_{in,max}	VELOCITÀ MASSIMA ROTAZIONE VITE A RICIRCOLO MAX BALLSCREW ROTATING INPUT SPEED	[rpm]	1000
S_{max}	CORSA MASSIMA STANDARD* MAX STANDARD STROKE*	[mm]	1000
a_{max}	ACCELERAZIONE MASSIMA IN USCITA MAX OUTPUT ACCELERATION	[m/sec ²]	3

* Per corse superiori, contattare il nostro servizio tecnico.
For longer strokes please contact our technical dept.

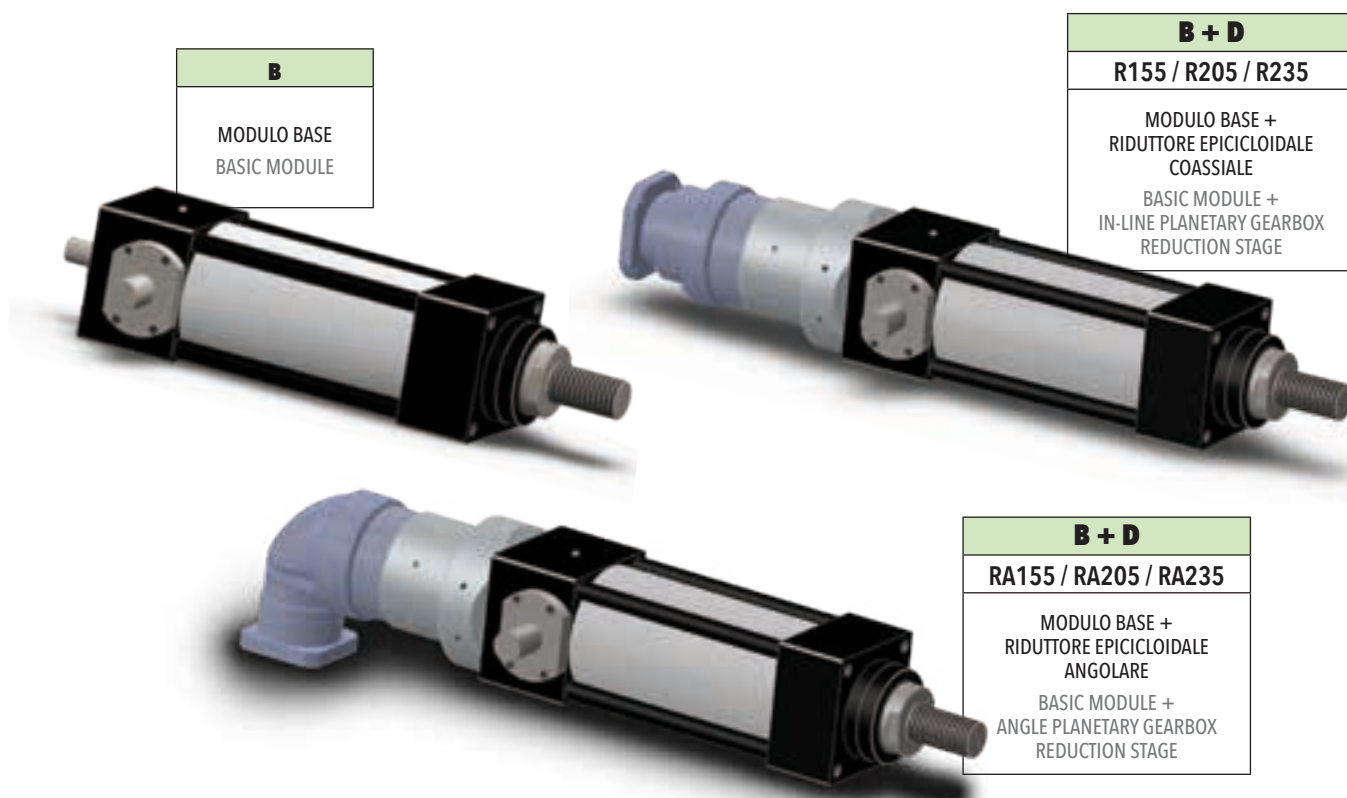

1. Informazioni tecniche per il calcolo Technical information for calculations

1.1	Forza assiale e velocità equivalenti / Equivalent axial force and equivalent linear speed	pg. 26
1.2	Capacità dinamica modulo base e durata statistica attuatore / Basic module dynamic load rating and Isomove statistical lifetime	pg. 27
1.3	Forza reale risultante massima ammissibile in dinamica ed in statica / Max admissible actual resultant force in dynamic and static use	pg. 29
1.4	Coppia in ingresso al modulo base / Torque at basic module input shaft	pg. 29
1.5	Coppia motore C_m / Motor torque C_m	pg. 30
1.6	Velocità lineare in uscita V_{out} / Output linear speed V_{out}	pg. 32

2. Sigla di ordinazione Ordering identification

2.1	Sigla di ordinazione da grandezza 32 a grandezza 100 XL / 32 to 100 XL Sizes Ordering identification	pg. 34
2.2	Sigla di ordinazione da grandezza 125 a grandezza 240 / 125 to 240 Sizes Ordering identification	pg. 36

3. Grandezze da 32 a 100 XL 32 to 100 XL Sizes

3.1	IE 32	
3.1.1	Caratteristiche tecniche / Technical features	pg. 38
3.1.2	Calcolo durata / Lifetime calculation	pg. 38
3.1.3	Calcolo coppia in ingresso al modulo base / Torque calculation at basic module input shaft	pg. 39
3.1.4	Calcolo coppia motore / Motor torque calculation	pg. 39
3.1.5	Potenza in ingresso alla trasmissione a cinghia (versione R) / Mechanical input power at belt gear stage (R type)	pg. 40
3.1.6	Caratteristiche dimensionali / Overall dimensions	pg. 41
3.1.7	Accessori / Accessories	pg. 43
3.2	IE 40	
3.2.1	Caratteristiche tecniche / Technical features	pg. 44
3.2.2	Calcolo durata / Lifetime calculation	pg. 44
3.2.3	Calcolo coppia in ingresso al modulo base / Torque calculation at basic module input shaft	pg. 45
3.2.4	Calcolo coppia motore / Motor torque calculation	pg. 45
3.2.5	Potenza in ingresso alla trasmissione a cinghia (versione R) / Mechanical input power at belt gear stage (R type)	pg. 46
3.2.6	Caratteristiche dimensionali / Overall dimensions	pg. 47
3.2.7	Accessori / Accessories	pg. 49

3.3	IE 50	
3.3.1	Caratteristiche tecniche / Technical features	pg. 50
3.3.2	Calcolo durata / Lifetime calculation	pg. 52
3.3.3	Calcolo coppia in ingresso al modulo base / Torque calculation at basic module input shaft	pg. 52
3.3.4	Calcolo coppia motore / Motor torque calculation	pg. 53
3.3.5	Potenza in ingresso alla trasmissione a cinghia (versione R) / Mechanical input power at belt gear stage (R type)	pg. 54
3.3.6	Caratteristiche dimensionali / Overall dimensions	pg. 56
3.3.7	Accessori / Accessories	pg. 61
3.4	IE 63	
3.4.1	Caratteristiche tecniche / Technical features	pg. 62
3.4.2	Calcolo durata / Lifetime calculation	pg. 64
3.4.3	Calcolo coppia in ingresso al modulo base / Torque calculation at basic module input shaft	pg. 64
3.4.4	Calcolo coppia motore / Motor torque calculation	pg. 65
3.4.5	Potenza in ingresso alla trasmissione a cinghia (versione R) / Mechanical input power at belt gear stage (R type)	pg. 66
3.4.6	Caratteristiche dimensionali / Overall dimensions	pg. 68
3.4.7	Accessori / Accessories	pg. 73
3.5	IE 80	
3.5.1	Caratteristiche tecniche / Technical features	pg. 74
3.5.2	Calcolo durata / Lifetime calculation	pg. 76
3.5.3	Calcolo coppia in ingresso al modulo base / Torque calculation at basic module input shaft	pg. 76
3.5.4	Calcolo coppia motore / Motor torque calculation	pg. 77
3.5.5	Potenza in ingresso alla trasmissione a cinghia (versione R) / Mechanical input power at belt gear stage (R type)	pg. 78
3.5.6	Caratteristiche dimensionali / Overall dimensions	pg. 80
3.5.7	Accessori / Accessories	pg. 85
3.6	IE 80 HL	
3.6.1	Caratteristiche tecniche / Technical features	pg. 86
3.6.2	Calcolo durata / Lifetime calculation	pg. 88
3.6.3	Calcolo coppia in ingresso al modulo base / Torque calculation at basic module input shaft	pg. 88
3.6.4	Calcolo coppia motore / Motor torque calculation	pg. 89
3.6.5	Potenza in ingresso alla trasmissione a cinghia (versione R) / Mechanical input power at belt gear stage (R type)	pg. 90
3.6.6	Caratteristiche dimensionali / Overall dimensions	pg. 92
3.6.7	Accessori / Accessories	pg. 97
3.7	IE 100	
3.7.1	Caratteristiche tecniche / Technical features	pg. 98
3.7.2	Calcolo durata / Lifetime calculation	pg. 100
3.7.3	Calcolo coppia in ingresso al modulo base / Torque calculation at basic module input shaft	pg. 100
3.7.4	Calcolo coppia motore / Motor torque calculation	pg. 101
3.7.5	Potenza in ingresso alla trasmissione a cinghia (versione R) / Mechanical input power at belt gear stage (R type)	pg. 102
3.7.6	Caratteristiche dimensionali / Overall dimensions	pg. 104
3.7.7	Accessori / Accessories	pg. 109

3.8IE 100 HL	
3.8.1	<i>Caratteristiche tecniche / Technical features</i> pg. 110
3.8.2	<i>Calcolo durata / Lifetime calculation</i> pg. 114
3.8.3	<i>Calcolo coppia in ingresso al modulo base / Torque calculation at basic module input shaft</i> pg. 114
3.8.4	<i>Calcolo coppia motore / Motor torque calculation</i> pg. 115
3.8.5	<i>Potenza in ingresso alla trasmissione a cinghia (versione R) / Mechanical input power at belt gear stage (R type)</i> pg. 116
3.8.6	<i>Caratteristiche dimensionali / Overall dimensions</i> pg. 118
3.8.7	<i>Accessori / Accessories</i> pg. 123
3.9IE 100 XL	
3.9.1	<i>Caratteristiche tecniche / Technical features</i> pg. 124
3.9.2	<i>Calcolo durata / Lifetime calculation</i> pg. 126
3.9.3	<i>Calcolo coppia in ingresso al modulo base / Torque calculation at basic module input shaft</i> pg. 126
3.9.4	<i>Calcolo coppia motore / Motor torque calculation</i> pg. 127
3.9.5	<i>Potenza in ingresso alla trasmissione a cinghia (versione R) / Mechanical input power at belt gear stage (R type)</i> pg. 128
3.9.6	<i>Caratteristiche dimensionali / Overall dimensions</i> pg. 130
3.9.7	<i>Accessori / Accessories</i> pg. 135
3.10 ACCESSORI DA IE 32 A IE 100 XL / ACCESSORIES FROM IE 32 TO IE 100 XL SIZES	
3.10.1	<i>FS: Forcella Stelo / Rod Fork</i> pg. 136
3.10.2	<i>SS: Snodo Sferico / Swivel Joint</i> pg. 137
3.10.3	<i>FV: Flangia Frontale / Front Flange</i> pg. 138
3.10.4	<i>PV: Piedino Verticale / Angle Foot</i> pg. 139
3.10.5	<i>CF: Cerniera Femmina / Rear Female Clevis with Pin</i> pg. 140
3.10.6	<i>KO: Controcerniera Orizzontale / Square Horizontal Counterclevis</i> pg. 141
3.10.7	<i>KM: Controcerniera Maschio / Male Clevis</i> pg. 142
3.10.8	<i>KS: Controcerniera Sferica / Male Clevis with Spherical Knuckle</i> pg. 143
3.10.9	<i>PE: Perni Oscillanti / Pivoting Pins</i> pg. 144
3.11 UNITÀ DI GUIDA / GUIDING UNIT	
3.11.1	<i>Tipo "H" / "H" type</i> pg. 145
3.11.2	<i>Tipo "U" / "U" type</i> pg. 146
3.11.3	<i>Codice di ordinazione / Designation code</i> pg. 146

4.

4.1. Categorie Motori / Riduttori / Rinvii angolari compatibili (32÷100XL) Compatible Motors / Planetary gearboxes / Angle bevel gearboxes categories (32 ÷ 100XL Sizes)

4.1	MOTORI / MOTORS pg. 148
4.2	RIDUTTORI / PLANETARY GEARBOXES pg. 149
4.3	RINVII ANGOLARI / ANGLE BEVEL GEARBOXES pg. 150

5. Grandezze 125 / 160 / 240 125 / 160 / 240 Sizes

5.1 IE 125

5.1.1	Caratteristiche tecniche / Technical features	pg. 152
5.1.2	Calcolo durata / Lifetime calculation.....	pg. 154
5.1.3	Calcolo coppia in ingresso al modulo base / Torque calculation at basic module input shaft.....	pg. 154
5.1.4	Calcolo coppia motore / Motor torque calculation	pg. 155
5.1.5	Potenza in ingresso alla trasmissione a cinghia (versione R) / Mechanical input power at belt gear stage (R type)	pg. 156
5.1.6	Caratteristiche dimensionali / Overall dimensions	pg. 157

5.2 IE 160

5.2.1	Caratteristiche tecniche / Technical features	pg. 162
5.2.2	Calcolo durata / Lifetime calculation.....	pg. 164
5.2.3	Calcolo coppia in ingresso al modulo base / Torque calculation at basic module input shaft.....	pg. 164
5.2.4	Calcolo coppia motore / Motor torque calculation	pg. 165
5.2.5	Potenza in ingresso alla trasmissione a cinghia (versione R) / Mechanical input power at belt gear stage (R type)	pg. 166
5.2.6	Caratteristiche dimensionali / Overall dimensions	pg. 168

5.3 IE 240

5.3.1	Caratteristiche tecniche / Technical features	pg. 174
5.3.2	Calcolo durata / Lifetime calculation.....	pg. 175
5.3.3	Calcolo coppia in ingresso al modulo base / Torque calculation at basic module input shaft.....	pg. 175
5.3.4	Calcolo coppia motore / Motor torque calculation	pg. 176
5.3.5	Caratteristiche dimensionali / Overall dimensions	pg. 177

6. Schede tecniche Riduttori / Rinvii angolari Planetary gearboxes / Angle bevel gearboxes datasheets

6.1	SCHEDA TECNICA RIDUTTORI / PLANETARY GEARBOXES DATASHEETS	pg. 182
6.2	SCHEDA TECNICA RINVII ANGOLARI / ANGLE BEVEL GEARBOXES DATASHEETS	pg. 184

7. Note tecniche generali General technical information

7.1	EXTRACORSA (CORSA DI SICUREZZA) / EXTRA-STROKE (SAFETY STROKE)	pg. 186
7.2	MONTAGGIO CON ATTUATORE BASCULANTE / INSTALLATION WITH TILTING ACTUATOR	pg. 186
7.3	GRADO PROTEZIONE IP / IP PROTECTION RATE	pg. 187
7.4	LUBRIFICAZIONE / LUBRICATION	pg. 187
7.5	POSIZIONE DI MONTAGGIO / MOUNTING POSITION	pg. 187
7.6	REVERSIBILITÀ / REVERSIBILITY	pg. 187
7.7	CAPACITÀ DI FATTORE DI SERVIZIO / DUTY CYCLE RATING	pg. 188
7.8	COLLEGAMENTO RIDUTTORE/RIVIO A MODULO BASE / TORQUE TRANSMISSION ELEMENT BETWEEN PLANETARY / ANGLE BEVEL GEARBOX AND BASIC MODULE	pg. 188

1.

Informazioni tecniche per il calcolo

Technical information
for calculations

1.1

Forza assiale e velocità equivalenti
Equivalent axial force and equivalent linear speed

L'attuatore ISOMOVE è progettato e costruito per essere sollecitato solo ed esclusivamente da forze esterne assiali (dirette lungo il suo asse longitudinale).

Qualunque forza esterna radiale (ortogonale all'asse dell'attuatore) è vietata e compromette il corretto funzionamento dello stesso. In questo caso decade ogni forma di garanzia.

Nel seguito quando parleremo di forza in generale intenderemo un carico puramente assiale.

Per effettuare la scelta corretta dell'attuatore si deve determinare la massima forza esterna reale risultante agente $F_{a,max}$.

Essa è la somma vettoriale di tutte le forze esterne agenti (forza di lavoro, forza di attrito, forza inerziale, forza peso, forze altre varie) nella condizione di lavoro più gravosa.

Tale condizione, così come i valori massimi di ciascun tipo di forza, deve esserci comunicata dal cliente.

Nella realtà applicativa le forze hanno un andamento nel tempo (grafico di forza) variabile e di conseguenza la forza esterna reale risultante F_a ha anch'essa un andamento variabile nel tempo:

$$F_a = f(t)$$

Per calcolare la durata statistica dell'attuatore, determinata dai suoi elementi volventi (cuscinetti e vite a ricircolo), dobbiamo calcolare la forza esterna media equivalente F_{eq} dal grafico di forza esterna reale risultante ed ancor prima la velocità lineare media equivalente V_{eq} dal profilo di moto reale del ciclo considerato.

Essi sono i valori equivalenti ai reali, ai fini del calcolo di durata statistica dell'attuatore, con probabilità pari al 90%. Essi sono definiti nel modo seguente:

ISOMOVE actuator has been conceived and is built to be loaded by purely external axial forces (i.e. whose axis is exactly actuator's axis).

Any external radial force (orthogonal to the actuator's axis) is not allowed because it jeopardizes its proper working. In this case there is no warranty on the product.

In the next pages we will generally write force meaning that it is a purely axial force.

To make actuator's proper choice you must first determine the max external actual resultant force acting on the actuator $F_{a,max}$.

It is the vectorial sum of all external acting forces (working force, friction force, inertial force, weight force and all other possible forces) in the worst possible condition.

This specific condition, as well as all the max values of each kind of force, must be communicated to SETEC GROUP in a clear way by the Customer/User.

In real applications forces vary during time (force graph) thus also the resultant external actual force F_a vary during time:

$$F_a = f(t)$$

To calculate the statistical lifetime of the actuator at 90% probability, which depends on its rolling elements (bearings and ballscrews) we must first determine 2 equivalent values of the actual force F_a and of the actual output linear speed V_{out} : F_{eq} and V_{eq} .

They are calculated with the following formulas:

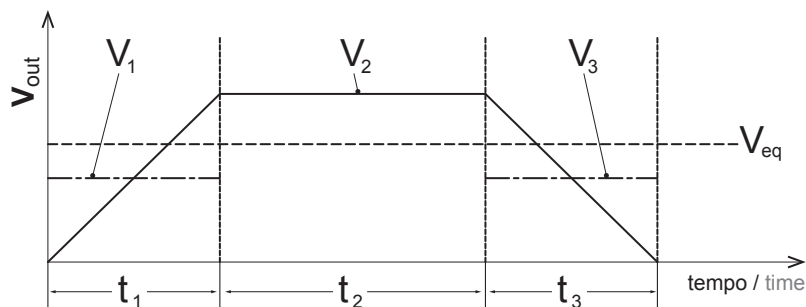

$$V_{eq} = \frac{1}{t_{tot}} \cdot \left(|V_1| \cdot t_1 + |V_2| \cdot t_2 + \dots + |V_n| \cdot t_n \right)$$

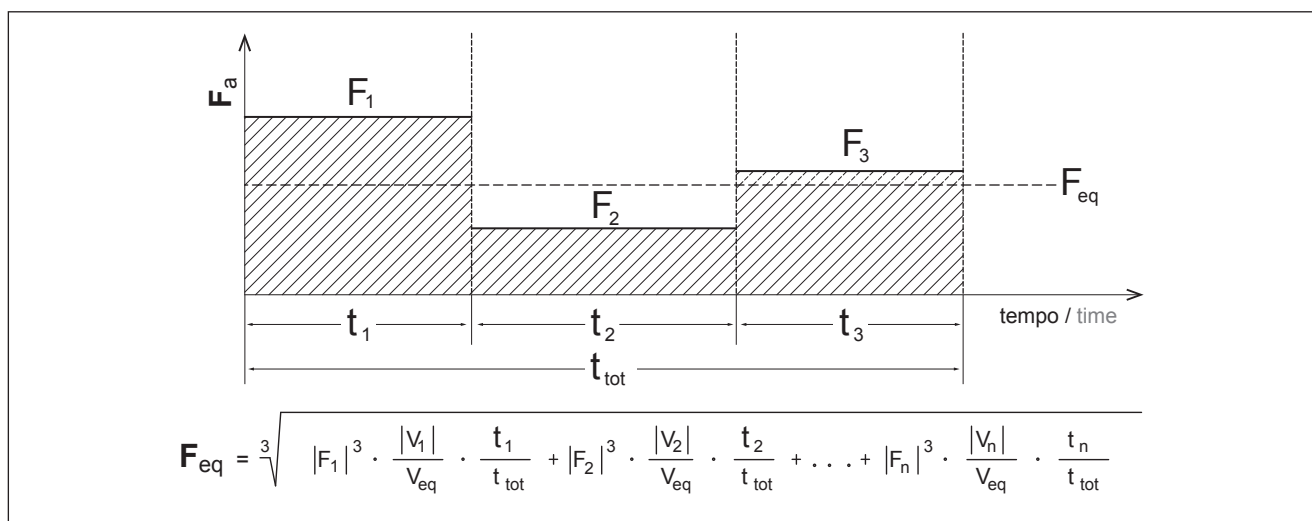

Nel tratto lineare crescente/decrescente il valore medio è la media aritmetica del valore minimo e massimo.

In the linear increasing/decreasing values (force or speed) the mean value is the arithmetical mean between the minimum and the maximum value of the line section considered.

1.2 Capacità dinamica modulo base e durata statistica attuatore Basic module dynamic load rating and Isomove statistical lifetime

Il parametro costruttivo del modulo base che caratterizza la durata statistica con probabilità al 90% dell'attuatore completo (modulo base + trasmissione eventuale) è la

CAPACITÀ DI CARICO DINAMICO **C_{am}**

Esso è il valore di forza equivalente **F_{eq}**, costante nel tempo, agente sull'attuatore, che determina una durata statistica pari ad 1 MILIONE DI GIRI della vite e dei supporti. Nel catalogo, in seguito, nelle sezioni relative a ciascuna grandezza, riportiamo nelle formule di durata il valore di questo parametro per ciascuna versione di modulo base. Esso è il valore numerico minore tra supporti e vite a sfere, quindi il più cautelativo.

La DURATA STATISTICA al 90% di PROBABILITÀ è calcolata nel modo seguente:

The characteristic constructive figure which determines the 90% probability lifetime of the complete actuator (basic module + transmission stage) is the

DYNAMIC LOAD RATING **C_{am}**

It is the equivalent force **F_{eq}** value, constant in time, acting on the actuator and determining a statistical lifetime of 1 MILLION TURNS of its rolling elements. In the following sections dedicated to each single actuator size we indicate in the lifetime formulas this value for each specific type. Of course it is the minimum value between bearings and ballscrews, thus a conservative one.

90% PROBABILITY LIFETIME is calculated as follows:

$$L_{10} = \left[\frac{C_{am}}{F_{eq}} \right]^3 \cdot 10^6 \quad \text{[milioni di giri]}$$

Che espressa in corsa dell'asta traslante diventa:

In terms of stroke:

$$L_{10,Km} = \left[\frac{C_{am}}{F_{eq}} \right]^3 \cdot P \quad \text{[Km]} \quad P = \text{passo vite / ballscrew pitch} \quad \text{[mm]}$$

I valori ricavati dalle formule precedenti sono puramente indicativi e sono validi nelle seguenti condizioni di esercizio:

- assenza di urti e vibrazioni
- lubrificazione dell'attuatore secondo ns. indicazioni
- montaggio con allineamenti di precisione
- assenza di carichi radiali
- temperatura ambiente compresa tra i -20°C e +70°C
- assenza di aggressivi chimici e di grandi depositi di polveri sull'attuatore
- funzionamento sempre per una corsa minima di lubrificazione adeguata

Esso rimane un valore statistico, ossia vero per il 90% di una quantità statisticamente rilevante di attuatori tutti uguali operanti in condizioni identiche; utile per avere un ordine di grandezza. Non può essere considerato un valore impegnativo e vincolante per il GRUPPO SETEC.

NOTA: quanto sopra è valido solo ed esclusivamente nel caso gli elementi di trasmissione siano gli "STANDARD SETEC GROUP DISPONIBILI" contenuti in questo catalogo. Qualora la trasmissione fosse a cura e carico del cliente quanto sopra non è più vero.

Al fine di facilitare il calcolo, nei paragrafi relativi ad ogni grandezza e versione sono riportate le formule specifiche della durata $L_{10,Km}$ dove inserire il solo valore F_{eq} :

Results of those above formulas are valid only if the actuator is used in the following operating conditions:

- no shocks and no vibrations
- respect of lubrication rules
- installation of the actuator with proper alignment tolerances
- no radial loads
- environmental temperature between -20° and + 70°C
- nor chemical products on/into the actuator neither big dust deposit on it
- always working with the minimum lubrication stroke

Lifetime value result is anyway a statistical value, thus true at 90% probability, for a relevant batch of all-the-same actuators operating in identical conditions. It is the of use only to have an idea of quantity and not an exact value. Thus it cannot be binding for SETEC GROUP.

TO BE NOTICED: all what above written is valid only in case the many available transmission stages are exactly the "AVAILABLE STANDARD SETEC GROUP" ones included in this catalogues. If Customer/User wants to use a something different from that all what above indicated will not be true anymore.

To make calculation easier, in each actuator size paragraph you can find the adapted specific formulas for $L_{10,Km}$ calculation, where you just put in the F_{eq} value:

ESEMPIO:

EXAMPLE:

CALCOLO CALCULATION	$L_{10,Km}$	[Km]
IE 32 P = 4 mm	$L_{10,Km} = \left[\frac{3370}{F_{eq}} \right]^3 \cdot 4$	$F_{eq} = [N]$
IE 32 P = 12 mm	$L_{10,Km} = \left[\frac{2200}{F_{eq}} \right]^3 \cdot 12$	$F_{eq} = [N]$

1.3 Forza reale risultante massima ammissibile in dinamica ed in statica Max admissible actual resultant force in dynamic and static use

Ciascuna grandezza e versione di attuatore è caratterizzata da 2 valori di forza da non superare mai:

Each actuator type has 2 characteristic force values never to exceed:

ATTUATORE IN MOVIMENTO

F_d = carico massimo dinamico applicabile.

È il valore di forza reale risultante massimo applicabile in movimento, ovvero in condizioni dinamiche.

ACTUATOR DURING MOTION

F_d = max admissible dynamic load.

It is the max admissible load that can act on the actuator during motion.

$$F_{a,max} \leq F_d$$

ATTUATORE FERMO

F_{st} = carico massimo statico applicabile

È il valore di forza reale risultante massimo applicabile in assenza di movimento, ovvero in condizioni statiche.

IDLE ACTUATOR

F_{st} = max admissible static load

It is the max admissible load that can act on the actuator without motion.

$$F_{a,max} \leq F_{st}$$

1.4 Coppia in ingresso al modulo base Torque at basic module input shaft

La coppia in ingresso al MODULO BASE C_{in} viene convertita in forza assiale in uscita F_a all'asta traslante dello stesso.

Essa è legata alla forza assiale in uscita dalla seguente relazione generale:

Input torque at BASIC MODULE shaft C_{in} is converted in output axial force F_a at its rod.

Formula linking those two figures is as follows:

$$C_{in} = \left[\frac{F_a \cdot P}{5652} \right]$$

P = passo vite / ballscrew pitch [mm]
 F_a = forza esterna reale risultante (forza da erogare) / external actual resultant force (to deliver) [N]

Per il modulo base standard si considera un rendimento meccanico pari a 0,90.

Basic module's MECHANICAL EFFICIENCY is 0,90.

Nelle tabelle relative ad ogni grandezza e versione è riportato il valore di coppia massima in ingresso al modulo base $C_{in,max}$, ovvero il massimo valore di coppia fornibile al modulo base, da non superare mai, corrispondente al valore che genera una forza pari al carico massimo dinamico applicabile F_d .

In each type's datasheet you will find the max admissible value of input torque at basic module shaft, never to exceed, $C_{in,max}$.

This torque value generates $F_a = F_d$.

Al fine di facilitare il calcolo, nei paragrafi relativi ad ogni grandezza e versione sono riportate le formule specifiche per calcolare la coppia in ingresso al modulo base C_{in} , inserendo il valore di F_a :

To make calculations easier in each model paragraph you will find the formula to get C_{in} , given a value of F_a :

ESEMPIO:

EXAMPLE:

CALCOLO CALCULATION	C_{in}	[Nm]
IE 32 $P = 4 \text{ mm}$	$C_{in} = \left[\frac{F_a \cdot 4}{5652} \right]$	$F_a = [\text{N}]$
IE 32 $P = 12 \text{ mm}$	$C_{in} = \left[\frac{F_a \cdot 12}{5652} \right]$	$F_a = [\text{N}]$

1.5

Coppia motore C_m Motor torque C_m

È la coppia che deve erogare il motore all'ingresso all'attuatore, ovvero in ingresso alla trasmissione dell'Isomove per erogare la forza F_a necessaria.

It is the torque the motor has to provide to the actuator, i.e. at the trasmission stage input, to deliver the requested F_a .

PARALLELO / PARALLEL TYPE

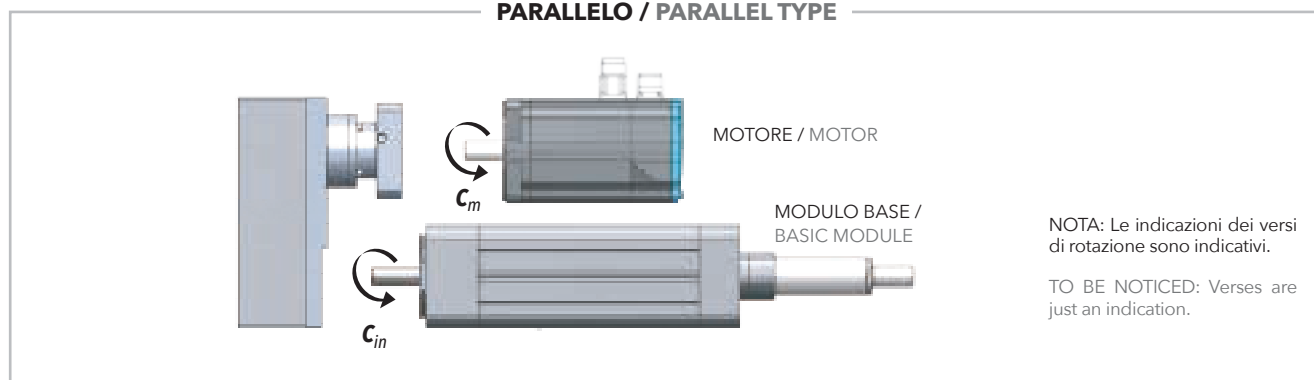

COASSIALE / IN-LINE TYPE

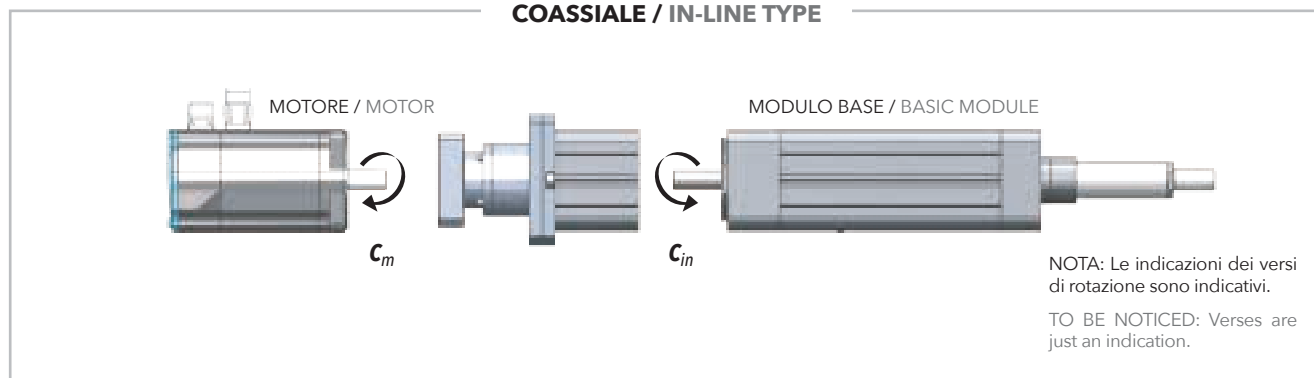

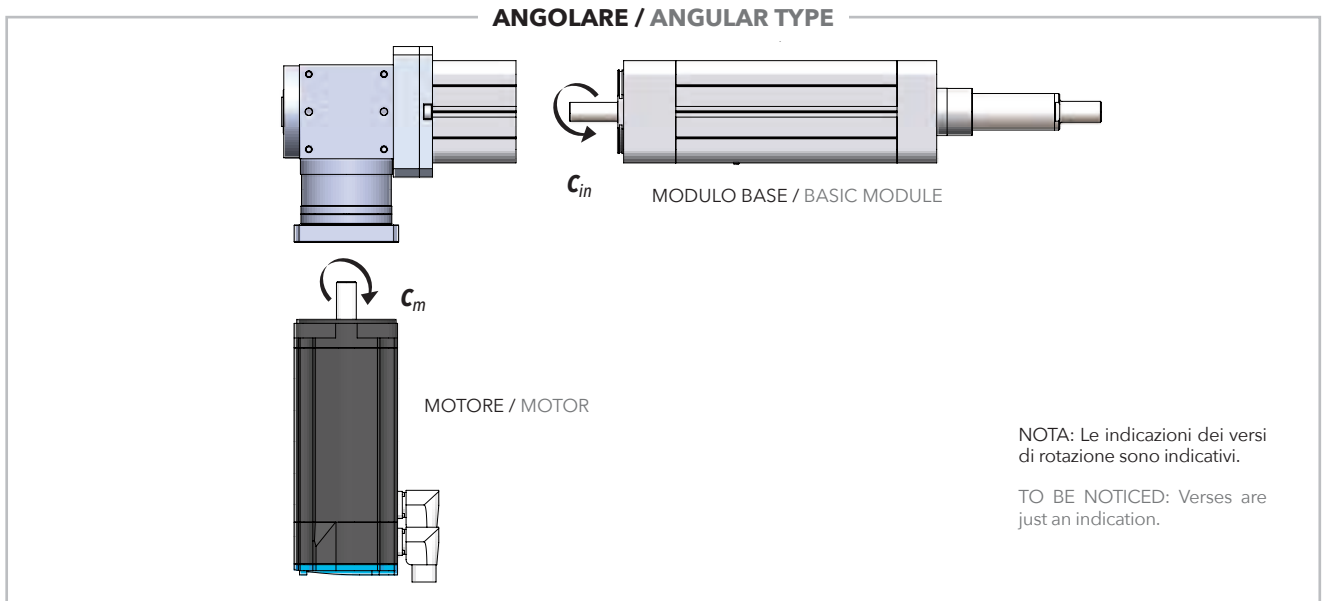

NOTA: Le formule seguenti non tengono in conto le inerzie proprie dell'attuatore, quindi i valori ottenuti saranno inferiori ai reali. Per un calcolo che le includa contattare il nostro ufficio tecnico.

REMARK: The following formulas do not take into account the inertias of the actuator, thus the calculated values are lower than actual ones. To get the actual values please take contact with our technical dept.

A seconda del tipo di trasmissione essa è definita nel modo seguente:

According to the types the motor torque is defined as follows:

CASO 1 / CASE 1

ISOMOVE B00 + D00 / D01	
<p>MODULO BASE / MODULO BASE + TRASMISSIONE COASSIALE SENZA RIDUZIONE</p> <p>In questo caso la coppia motore coincide con la coppia in ingresso al modulo base:</p>	<p>BASIC MODULE / BASIC MODULE + IN-LINE TRANSMISSION W/O REDUCTION STAGE</p> <p>In this case the motor torque is the input torque at basic module shaft:</p>
$C_m = C_{in} \quad [Nm]$	

CASO 2 / CASE 2

ISOMOVE B00 + D02 / A01	
<p>MODULO BASE + RIDUTTORE EPICICLOIDALE COASSIALE / MODULO BASE + RINVIO ANGOLARE</p> <p>In questo caso la coppia motore è legata alla coppia in ingresso al modulo base dalla relazione seguente:</p>	<p>BASIC MODULE + IN-LINE PLANETARY GEARBOX / BASIC MODULE + ANGLE BEVEL GEARBOX STAGE</p> <p>In this case the motor torque is related to the input torque at basic module shaft as follows:</p>
$C_m = \left[\frac{C_{in}}{R \cdot \eta} \right] + C_s \quad [Nm]$	<p>R = rapporto di riduzione riduttore/rinvio angolare / planetary/angle bevel gearbox reduction ratio</p> <p>η = rendimento meccanico del riduttore/rinvio / planetary/angle bevel gearbox mechanical efficiency = 0,90</p> <p>C_s = coppia a vuoto assorbita dal riduttore/rinvio / planetary/angle bevel gearbox idle torque [Nm]</p>

CASO 3 / CASE 3

ISOMOVE B00 + R00 / R01

MODULO BASE + TRASMISSIONE A CINGHIA IN PARALLELO

In questo caso la coppia motore è legata alla coppia in ingresso al modulo base dalla relazione seguente:

$$C_m = \left[\frac{C_{in}}{R \cdot \eta} \right] \quad [\text{Nm}]$$

BASIC MODULE + PARALLEL BELT GEARBOX STAGE

In this case the motor torque is related to the input torque at basic module shaft as follows:

- R = rapporto di riduzione trasmissione a cinghia, disponibili R=1 oppure R=2 / belt gearbox reduction ratio, available R=1 or R=2
 η = rendimento meccanico trasmissione a cinghia = 0,90
 belt gear stage mechanical efficiency

CASO 4 / CASE 4

ISOMOVE B00 + R02

MODULO BASE + TRASMISSIONE A CINGHIA IN PARALLELO R=1 + RIDUTTORE

In questo caso la coppia motore è legata alla coppia in ingresso al modulo base dalla relazione seguente:

$$C_m = \left[\frac{C_{in}}{R \cdot \eta} \right] + C_s \quad [\text{Nm}]$$

BASIC MODULE + PARALLEL BELT GEARBOX STAGE R=1 + IN-LINE PLANETARY GEARBOX REDUCTION STAGE

In this case the motor torque is related to the input torque at basic module shaft as follows:

- R = rapporto di riduzione riduttore / planetary gearbox reduction ratio
 η = rendimento meccanico totale (cinghia + epicicloidale) / (planetary gearbox + belt gear) total mechanical efficiency = 0,81
 C_s = coppia a vuoto assorbita dal riduttore / planetary gearbox idle torque

Nelle tabelle relative ad ogni grandezza e versione è riportato il valore di coppia massima motore in ingresso all'attuatore $C_{m,max}$ ovvero il massimo valore di coppia fornibile all'attuatore dal motore, da non superare mai, corrispondente al valore che genera una forza pari al carico massimo dinamico applicabile C_d .

In each type datasheet you will find the max admissible value of motor torque $C_{m,max}$ at actuator's input.

Never exceed it.

$C_{m,max}$ generates C_d .

1.6

Velocità lineare in uscita V_{out}
Output linear speed V_{out}

La velocità assiale dell'asta traslante dell'attuatore V_{out} è legata alla velocità angolare di ingresso all'attuatore N_{out} dalla seguente relazione:

$$V_{out} = \left[\frac{N_{mot} \cdot P}{60 \cdot R} \right] \quad [\text{mm/s}]$$

Actuator's rod output linear speed V_{out} is related to input motor speed N_{out} as follows:

- P = passo vite / ballscrew pitch [mm]
 N_{mot} = velocità angolare del motore (in ingresso all'attuatore) [rpm]
 rotational motor speed (at actuator's input)
 R = rapporto di riduzione tra motore e modulo base (è il rapporto di riduzione dello stadio di riduzione dell'attuatore) reduction ratio between motor and basic module (it is the total reduction gear of the ISOMOVE)

Nelle tabelle relative ad ogni grandezza e versione è riportato il valore di velocità angolare massima ammissibile $N_{in,max}$ in ingresso al modulo base, da non superare mai, corrispondente al valore che genera una velocità assiale dell'asta traslante massima $V_{out,max}$.

In each type datasheet you will find the max admissible input speed at the basic module shaft $N_{in,max}$ never to exceed, which delivers the max admissible output linear speed of the rod $V_{out,max}$.

2.

Sigla di ordinazione

Ordering identification

2.1

Grandezze da 32 a 100XL
From 32 to 100XL type

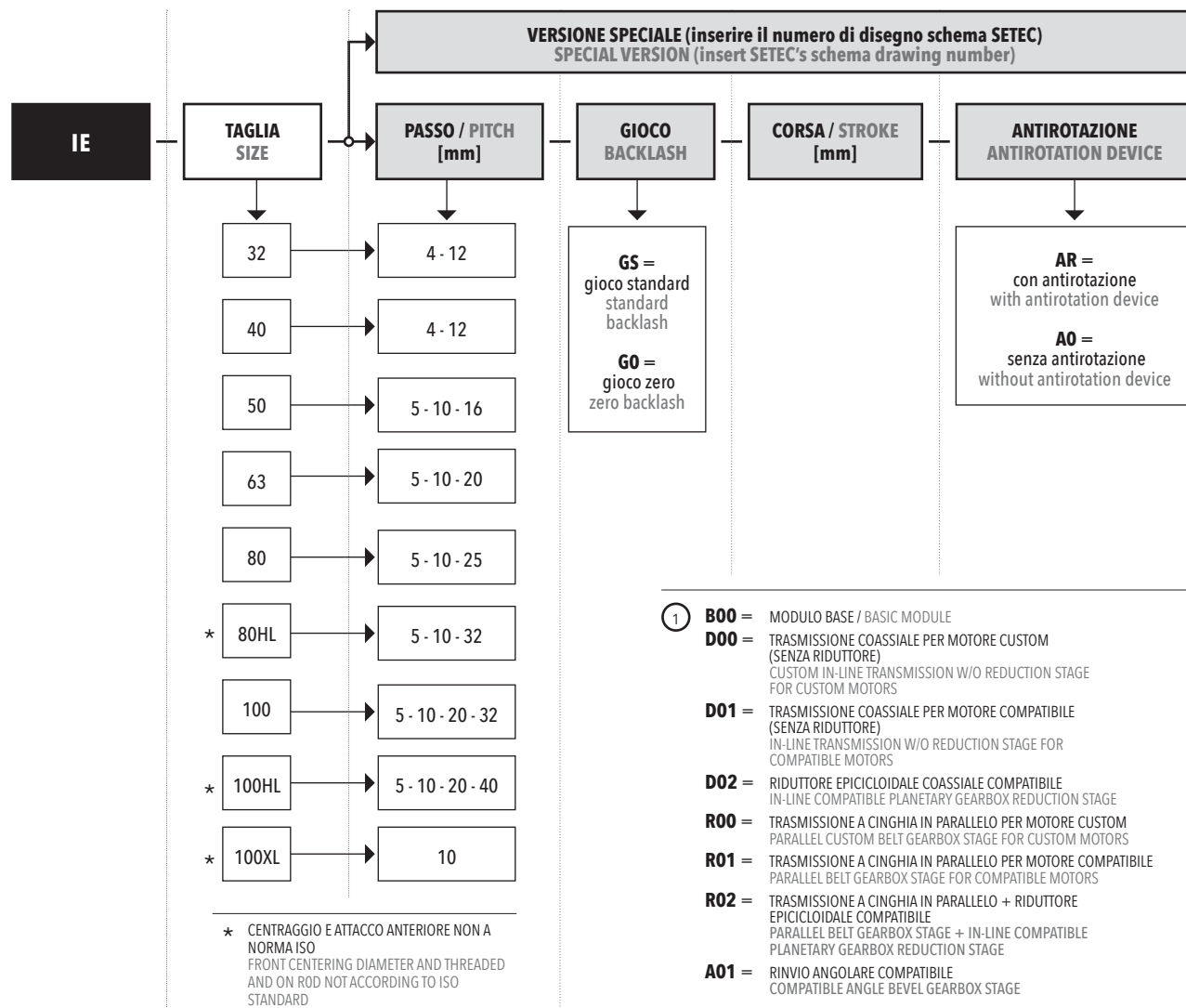

- ① **B00** = MODULO BASE / BASIC MODULE
- D00** = TRASMISSIONE COASSIALE PER MOTORE CUSTOM (SENZA RIDUTTORE)
CUSTOM IN-LINE TRANSMISSION W/O REDUCTION STAGE FOR CUSTOM MOTORS
- D01** = TRASMISSIONE COASSIALE PER MOTORE COMPATIBILE (SENZA RIDUTTORE)
IN-LINE TRANSMISSION W/O REDUCTION STAGE FOR COMPATIBLE MOTORS
- D02** = RIDUTTORE EPICICLOIDALE COASSIALE COMPATIBILE
IN-LINE COMPATIBLE PLANETARY GEARBOX REDUCTION STAGE
- R00** = TRASMISSIONE A CINGHIA IN PARALLELO PER MOTORE CUSTOM
PARALLEL CUSTOM BELT GEARBOX STAGE FOR CUSTOM MOTORS
- R01** = TRASMISSIONE A CINGHIA IN PARALLELO PER MOTORE COMPATIBILE
PARALLEL BELT GEARBOX STAGE FOR COMPATIBLE MOTORS
- R02** = TRASMISSIONE A CINGHIA IN PARALLELO + RIDUTTORE EPICICLOIDALE COMPATIBILE
PARALLEL BELT GEARBOX STAGE + IN-LINE COMPATIBLE PLANETARY GEARBOX REDUCTION STAGE
- A01** = RINVIO ANGOLARE COMPATIBILE
COMPATIBLE ANGLE BEVEL GEARBOX STAGE

- ② PER LE DIMENSIONI DEI MOTORI VEDERE CAPITOLO 4
FOR MOTOR DIMENSIONS SEE CHAPTER 4
- ③ PER LE DIMENSIONI DEI RIDUTTORI VEDERE CAPITOLO 4
FOR PLANETARY GEARBOX DIMENSIONS SEE CHAPTER 4
- ④ PER LE DIMENSIONI DEI RINVII ANGOLARI VEDERE CAPITOLO 4
FOR ANGLE BEVEL GEARBOX DIMENSIONS SEE CHAPTER 4

Esempi di designazione prodotto STANDARD:

IE	63	5	GS	360	A0
IE	50	5	GS	250	AR
IE	100HL	10	GS	450	A0
IE	80	10	GO	500	AR

STANDARD product designation examples:

Esempio di designazione prodotto SPECIALE:

IE	32	I-E032-XXXX-XXX-XXXX-REVXX			
----	----	----------------------------	--	--	--

SPECIAL product designation example:

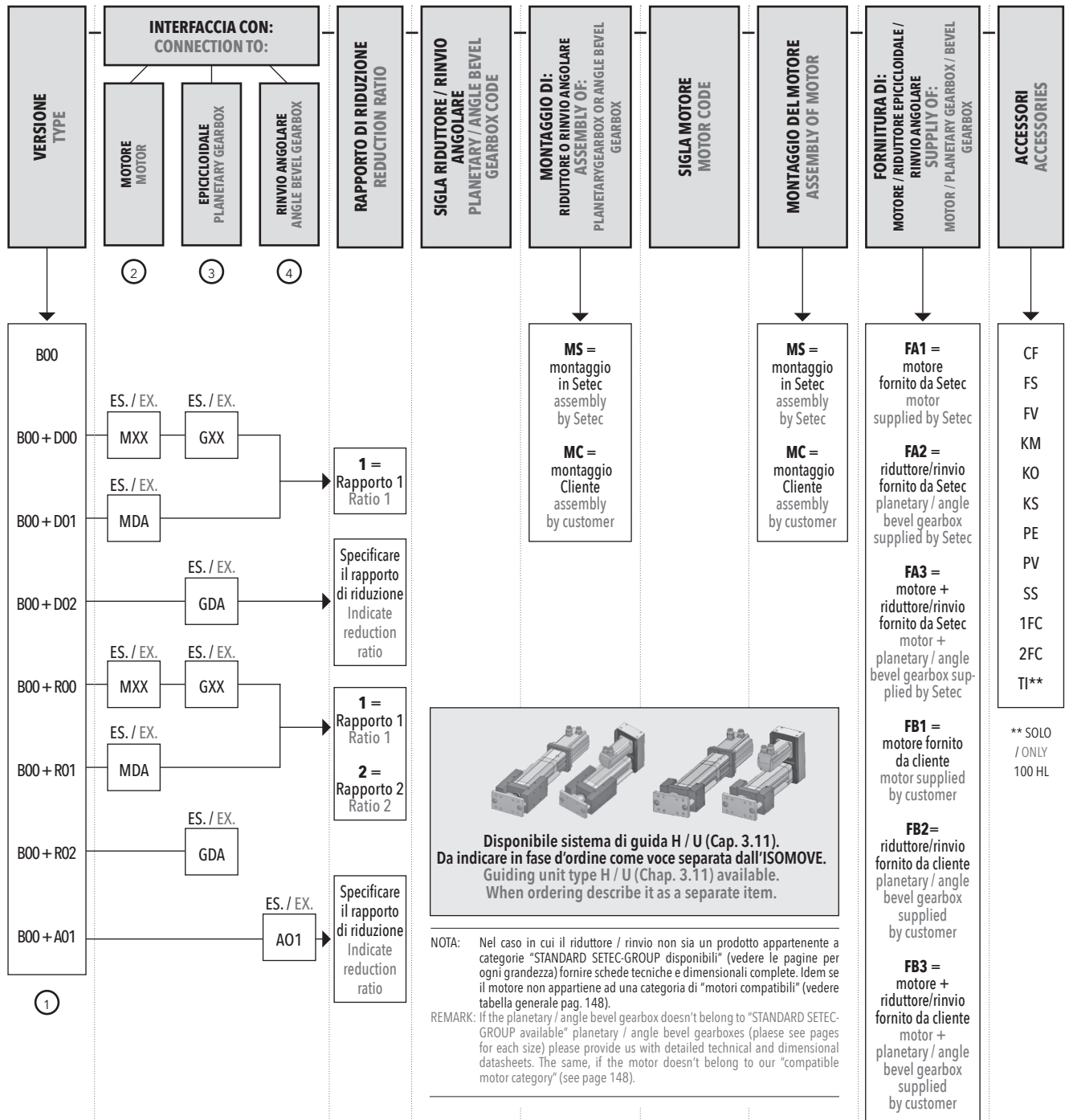

B00 + D02	GCA	10	LP070	MC	1FK7022	MC	FB3	FV
B00 + D01	MCC	1			MCS09	MS	FA1	
B00 + A01	ADA	3	ATB110	MS	BMH1003P	MC	FA2+FB1	
B00 + R02	GDA	5	AE090	MS	BSH703P	MS	FA2+FB1	FS-PE

2.2

Grandezze 125 - 160 - 240 125 - 160 - 240 type

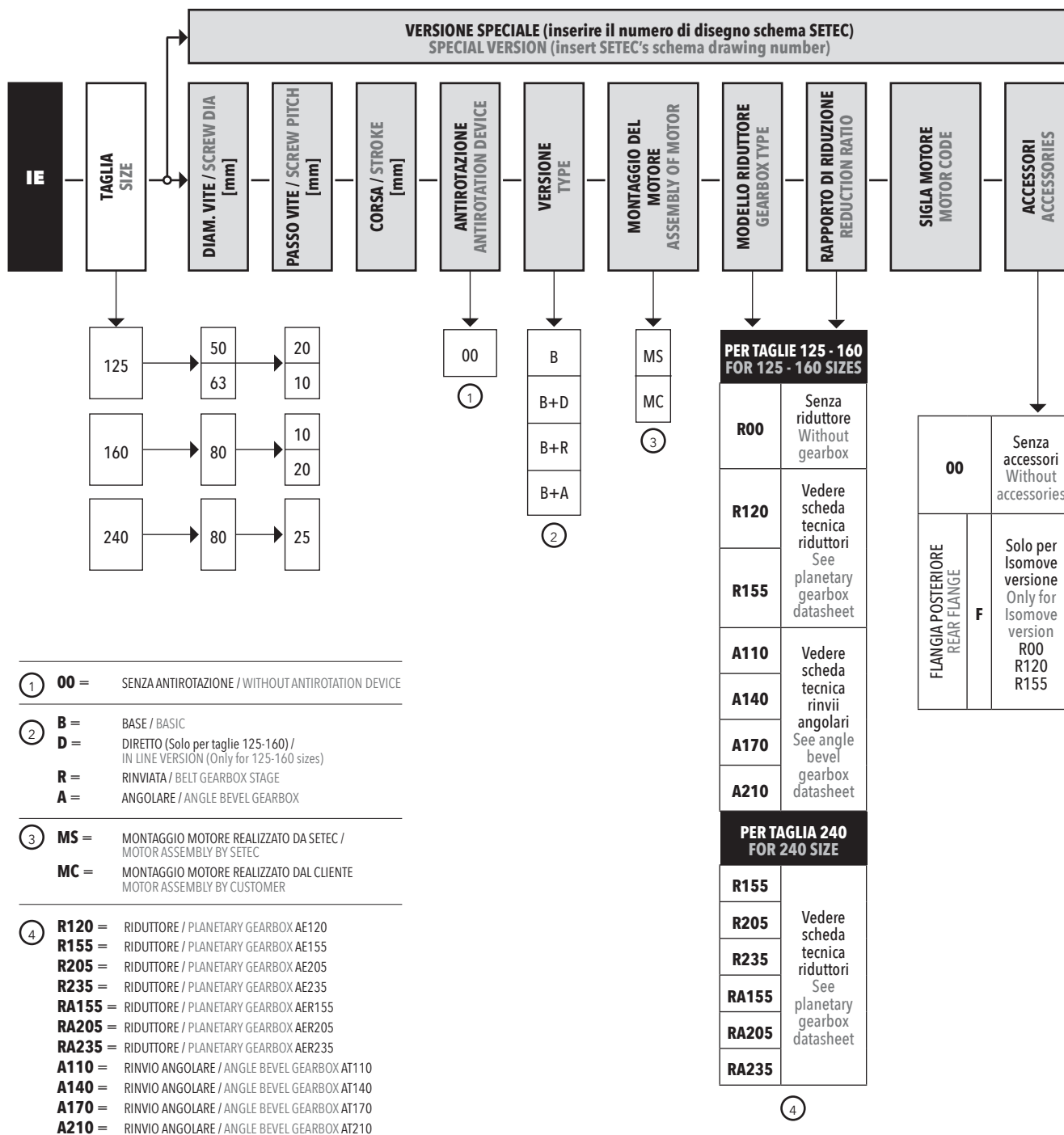

Esempio di designazione prodotto STANDARD:

STANDARD product designation example:

IE - **125** - **63** - **10** - **300** - **00** - **B+A** - **MC** - **A110** - **4** - **BSH1004P** - **00**

Esempio di designazione prodotto SPECIALE:

SPECIAL product designation example:

IE - **125** - **I-E125-XXXX - XXX - XXXX - REVXX**

3.

Grandezze da 32 a 100XL

32 to 100XL Sizes

IE 32	pg. 38
IE 40	pg. 44
IE 50	pg. 50
IE 63	pg. 62
IE 80	pg. 74
IE 80HL	pg. 86
IE 100	pg. 98
IE 100HL	pg. 110
IE 100XL	pg. 124
Accessori / Accessories	pg. 136

3.1

IE 32

3.1.1 Caratteristiche tecniche

3.1.1 Technical features

ISOMOVE IE 32			4	12
P	PASSO VITE / SCREW LEAD	[mm]	4	12
D	DIAMETRO VITE / SCREW DIAMETER	[mm]	12	12
F_d	CARICO MASSIMO DINAMICO APPLICABILE MAX ADMISSIBLE DYNAMIC LOAD	[N]	3000*	2000*
C_{in,max}	PER AVERE $F_a = F_d$ TO GET	[Nm]	2,1	4,2
C_{m,max}	"CASO 1" / "CASE 1": B00 + D00/D01	[Nm]	2,1	4,2
	"CASO 3" / "CASE 3": B00 + R00/R01	[Nm]	2,3	4,6
F_{st}	CARICO MASSIMO STATICO APPLICABILE MAX ADMISSIBLE STATIC LOAD	[N]	3400	3400
V_{out,max} N_{in,max}	VELOCITÀ DI TRASLAZIONE MASSIMA IN USCITA / ROTAZIONE MASSIMA VITE RDS MAX OUTPUT SPEED / MAX BALLSCREW ROTATING INPUT SPEED	[mm/sec] [rpm]	200 / 3000	600 / 3000
a_{max}	ACCELERAZIONE MASSIMA IN USCITA / MAX OUTPUT ACCELERATION	[m/sec ²]	1	2
S_{max}	CORSA MASSIMA STANDARD / MAX STANDARD STROKE	[mm]	500**	500**
	PESO MODULO BASE CORSA 0 mm / PESO OGNI 100 mm DI CORSA BASIC MODULE WEIGHT FOR 0 mm STROKE / WEIGHT FOR ADDITIONAL 100 mm STROKE	[Kg]	1,2 / 0,3	1,2 / 0,3
G_{s,max}	GIOCO ASSIALE MASSIMO PER CHIOCCIOLA STANDARD MAX AXIAL BACKLASH FOR STANDARD BALLSCREW ASSEMBLY	[mm]	0,02	0,02
G_Z	GIOCO "0" DELLA CHIOCCIOLA / "0" BACKLASH BALLSCREW ASSEMBLY		NON DISPONIBILE / NOT AVAILABLE	
L_{10,Km}	DURATA / LIFETIME	[Km]	VEDI TABELLA / SEE TABLE	
	VERSIONI DISPONIBILI / AVAILABLE TYPES		D00/D01/R00/R01	D00/D01/R00/R01
	ACCESSORI DISPONIBILI / AVAILABLE ACCESSORIES		VEDI PARAGRAFO / SEE PARAGRAPH 3.10 (pg. 136)	

* Per le versioni R00/R01 controllare con il grafico di pagina 40. / For R00/R01 types please check graph at page 40.

** Per corse superiori, contattare il nostro servizio tecnico. / For longer strokes please contact our technical dpt.

3.1.2 Calcolo durata

3.1.2 Lifetime calculation

IE 32 P = 4 mm	$L_{10,Km} = \left[\frac{3370}{F_{eq}} \right]^3 \cdot 4$	L_{10,Km} = [Km] F_{eq} = [N]
IE 32 P = 12 mm	$L_{10,Km} = \left[\frac{2200}{F_{eq}} \right]^3 \cdot 12$	L_{10,Km} = [Km] F_{eq} = [N]

3.1.3 Calcolo coppia in ingresso al modulo base

3.1.3 Torque calculation at basic module input shaft

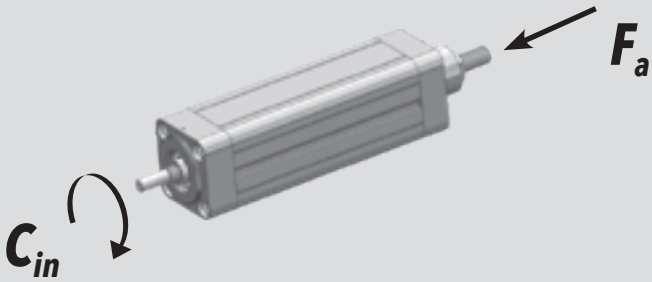
		
<p>IE 32 P = 4 mm</p>	$C_{in} = \left[\frac{F_a \cdot 4}{5652} \right]$	<p>$C_{in} = [Nm]$ $F_a = [N]$</p>
<p>IE 32 P = 12 mm</p>	$C_{in} = \left[\frac{F_a \cdot 12}{5652} \right]$	<p>$C_{in} = [Nm]$ $F_a = [N]$</p>

3.1.4 Calcolo coppia motore

3.1.4 Motor torque calculation

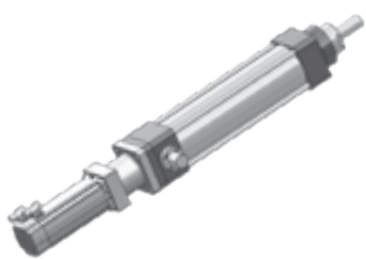
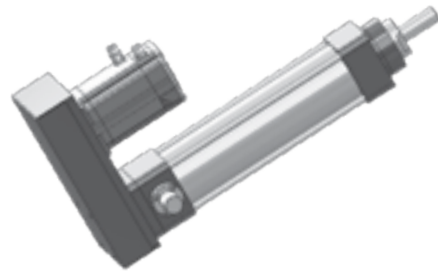
<p>CASO / CASE 1</p>	<p style="text-align: center;">ISOMOVE B00 + D00 / D01</p> <div style="display: flex; align-items: center; justify-content: center;">  <div style="text-align: center;"> $C_m = C_{in}$ <p>[Nm]</p> </div> </div>
<p>CASO / CASE 3</p>	<p style="text-align: center;">ISOMOVE B00 + R00 / R01</p> <div style="display: flex; align-items: center; justify-content: center;">  <div style="text-align: center;"> $C_m = \left[\frac{C_{in}}{R \cdot \eta} \right]$ <p>[Nm]</p> </div> </div> <p>R = rapporto di riduzione trasmissione a cinghia, disponibile R=1 belt gearbox reduction ratio, available R=1 η = rendimento meccanico / mechanical efficiency = 0,90</p>

3.1.5 Potenza in ingresso alla trasmissione a cinghia (versione R)

3.1.5 Mechanical input power at belt gear stage (R type)

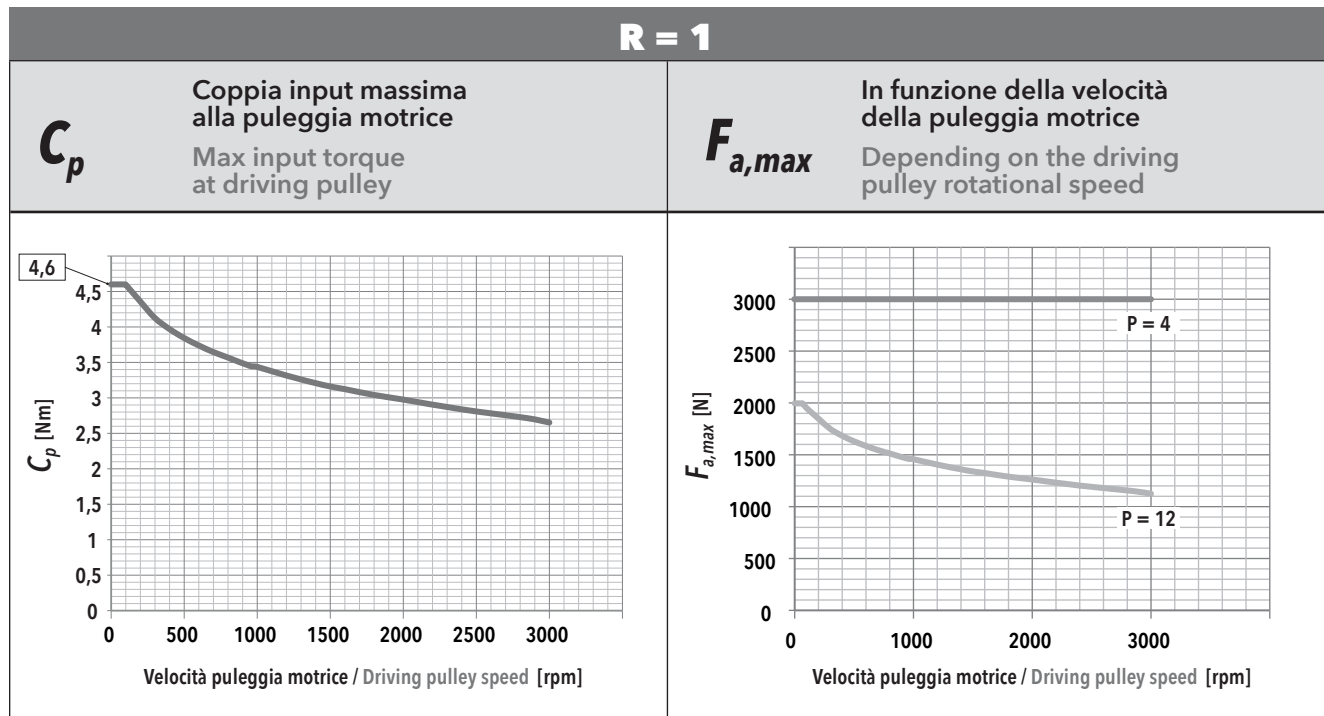

F_r Forza radiale su asse puleggia motrice in funzione di C_{in}
Radial force on driving pulley as a function of C_{in}

f_t Frequenza di vibrazione della cinghia per il tensionamento (al montaggio)
Vibration frequency of the belt for its tensioning (during assembly)

IE 32 - PASSO / PITCH 4					
F_a [N]		V_{out} [mm/s]			
		20	80	140	200
3000	F_r [N]	140	141	142	143
	f_t [Hz]	328	329	330	331
2700	F_r [N]	127	127	127	129
	f_t [Hz]	312	312	313	314
2400	F_r [N]	112	112	113	114
	f_t [Hz]	293	294	295	296
2100	F_r [N]	98	99	100	101
	f_t [Hz]	276	276	277	278
1800	F_r [N]	84	85	86	87
	f_t [Hz]	253	254	256	258
1500	F_r [N]	70	70	71	73
	f_t [Hz]	232	233	234	236
1200	F_r [N]	57	57	58	58
	f_t [Hz]	209	209	210	212
900	F_r [N]	41	42	43	44
	f_t [Hz]	179	180	182	184
600	F_r [N]	28	28	29	30
	f_t [Hz]	147	148	149	152
300	F_r [N]	13	14	15	16
	f_t [Hz]	101	105	108	111

IE 32 - PASSO / PITCH 12					
F_a [N]		V_{out} [mm/s]			
		60	240	420	600
2000	F_r [N]	282			
	f_t [Hz]	465			
1800	F_r [N]	253			
	f_t [Hz]	441			
1600	F_r [N]	225	226		
	f_t [Hz]	416	416		
1400	F_r [N]	197	197		
	f_t [Hz]	389	389		
1200	F_r [N]	169	169	170	
	f_t [Hz]	360	360	361	
1000	F_r [N]	141	141	142	143
	f_t [Hz]	329	329	330	331
800	F_r [N]	113	113	114	115
	f_t [Hz]	294	294	295	297
600	F_r [N]	85	85	86	87
	f_t [Hz]	255	255	256	258
400	F_r [N]	56	57	57	59
	f_t [Hz]	208	209	210	212
200	F_r [N]	28	29	29	30
	f_t [Hz]	147	148	150	153

3.1.6 Caratteristiche dimensionali

3.1.6 Overall dimensions

NOTA: Dati categorie motori / riduttori / rinvii al capitolo 4.

REMARK: Motors / Planetary / Angle bevel gearbox categories data at chapter 4.

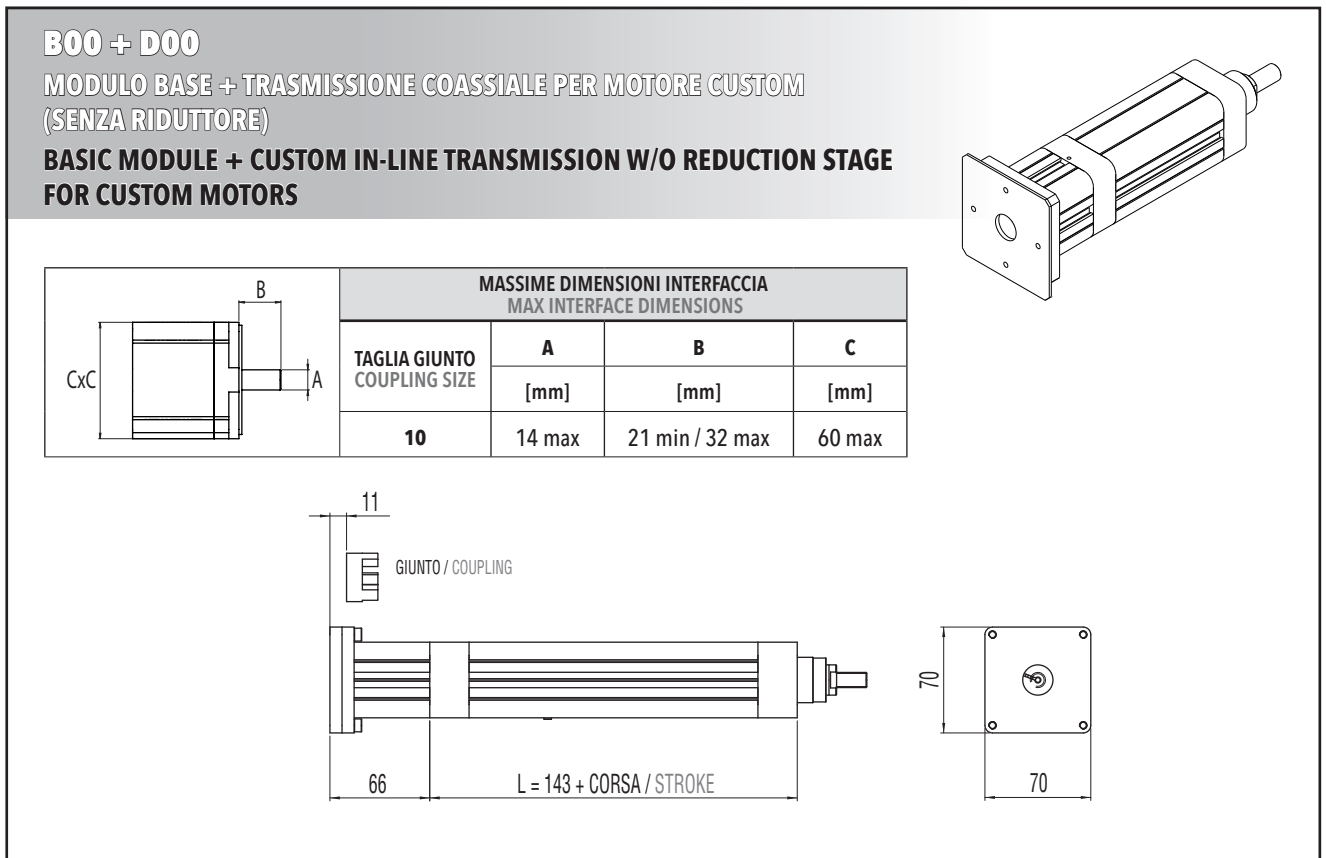
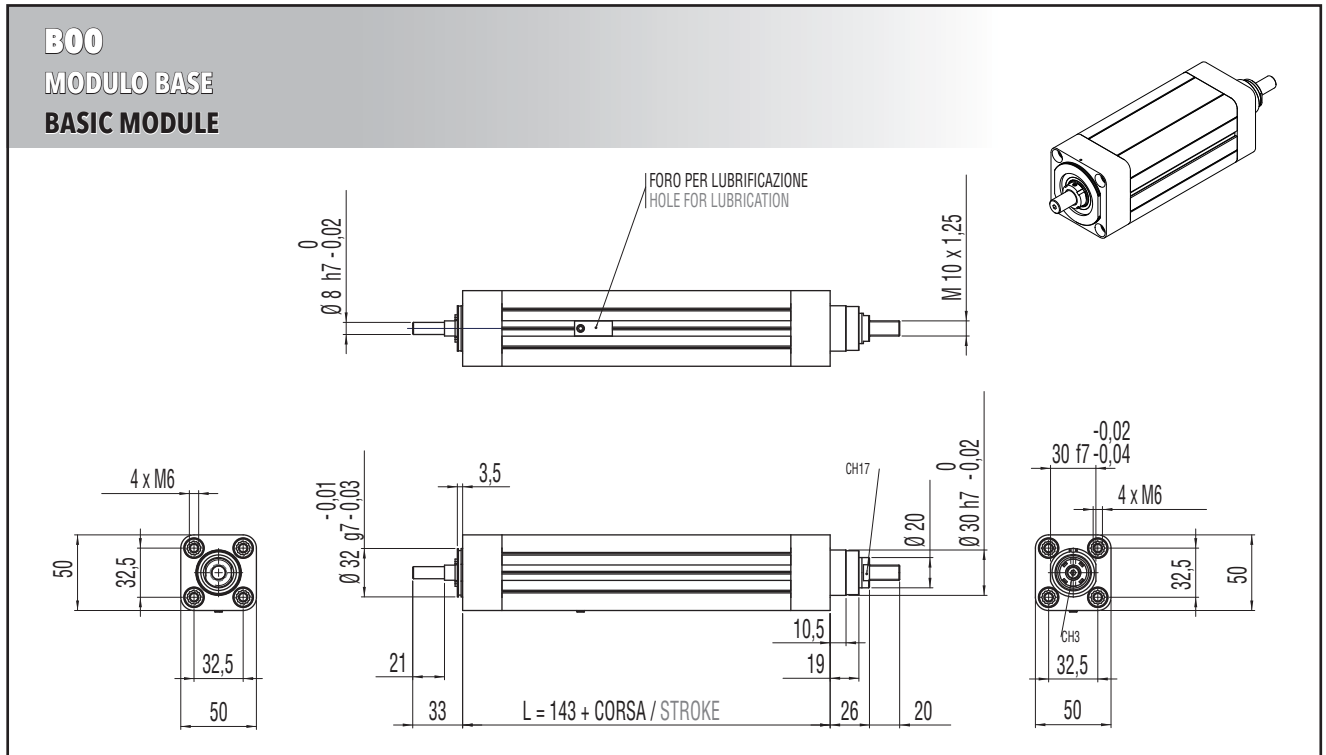

B00 + D01

MODULO BASE + TRASMISSIONE COASSIALE PER MOTORE COMPATIBILE
(SENZA RIDUTTORE)

**BASIC MODULE + IN-LINE TRANSMISSION W/O REDUCTION STAGE FOR
COMPATIBLE MOTORS**

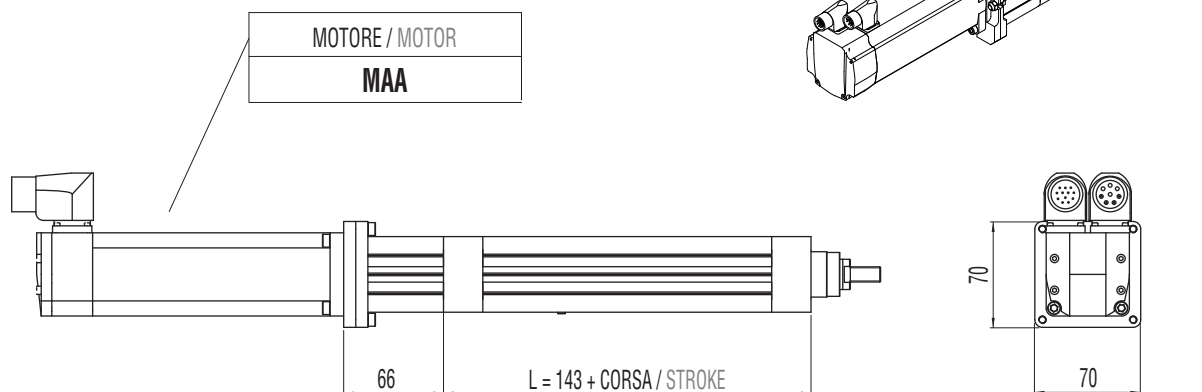

B00 + R00

MODULO BASE + TRASMISSIONE A CINGHIA IN PARALLELO PER MOTORE CUSTOM

BASIC MODULE + PARALLEL CUSTOM BELT GEARBOX STAGE FOR CUSTOM MOTORS

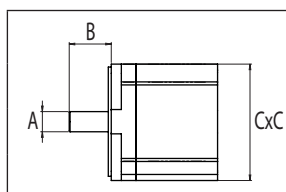

MASSIME DIMENSIONI INTERFACCIA MAX INTERFACE DIMENSIONS			
	A	B	C
	[mm]	[mm]	[mm]
R=1:1	14 max	24 min / 42 max	60 max

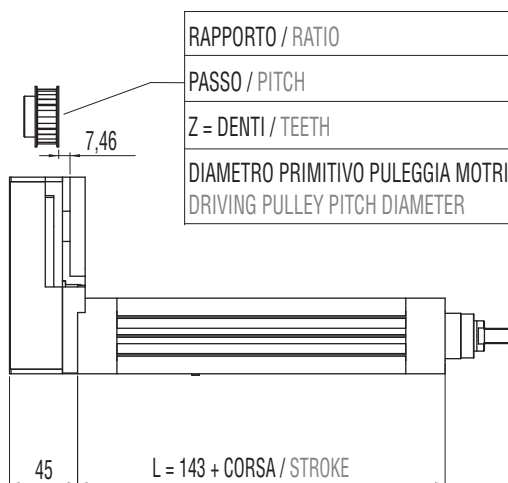
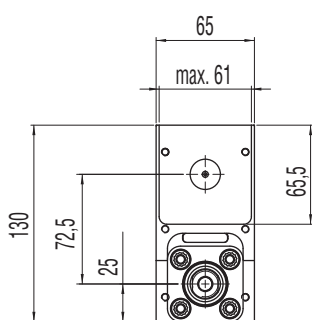
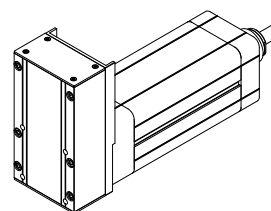

RAPPORTO / RATIO	1:1
PASSO / PITCH	5 mm
Z = DENTI / TEETH	24
DIAMETRO PRIMITIVO PULEGGIA MOTRICE DRIVING PULLEY PITCH DIAMETER	38,2 mm

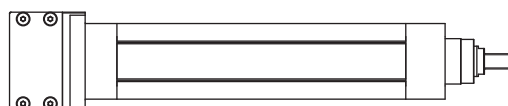
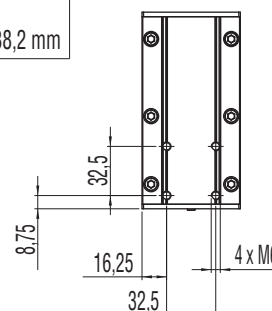

B00 + R01

MODULO BASE + TRASMISSIONE A CINGHIA IN PARALLELO PER MOTORE COMPATIBILE

BASIC MODULE + PARALLEL BELT GEARBOX STAGE FOR COMPATIBLE MOTORS

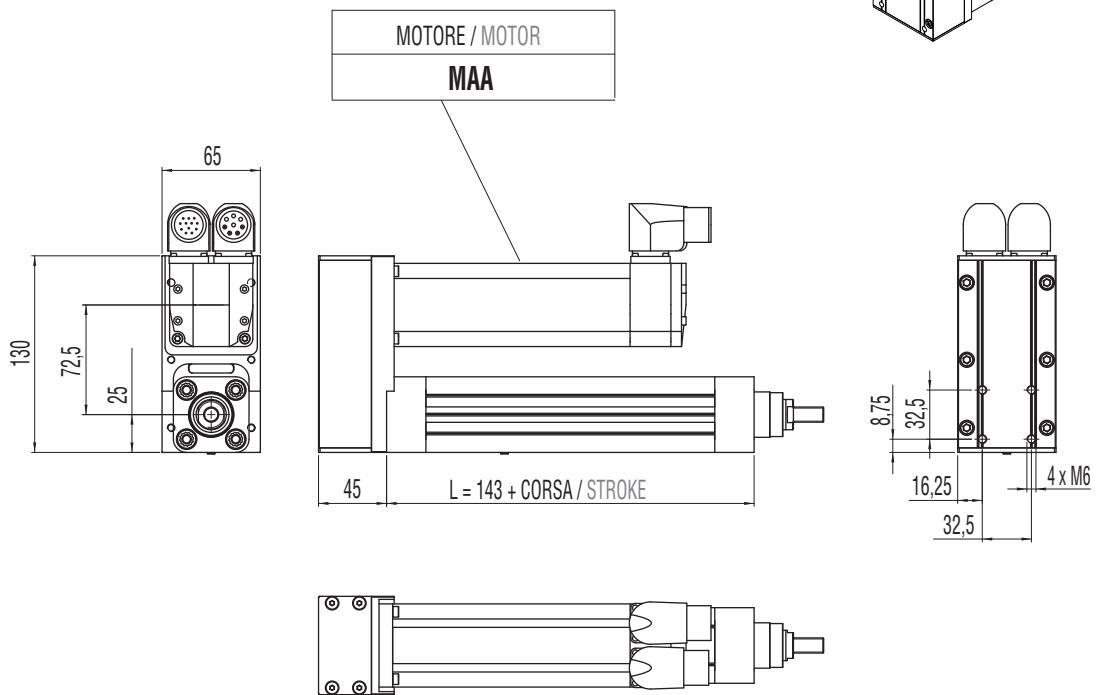
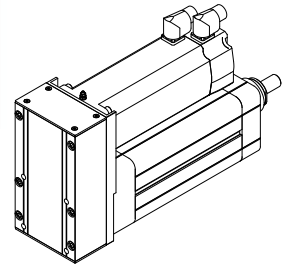

3.1.7 Accessori disponibili

Per le tabelle e i disegni tecnici degli accessori disponibili fare riferimento al paragrafo 3.10 (da pag. 136).

3.1.7 Available accessories

For tables and drawings please refer to paragraph 3.10 (from page 136).

3.2

IE 40

3.2.1 Caratteristiche tecniche

3.2.1 Technical features

ISOMOVE IE 40			4	12
P	PASSO VITE / SCREW LEAD	[mm]	4	12
D	DIAMETRO VITE / SCREW DIAMETER	[mm]	12	12
F_d	CARICO MASSIMO DINAMICO APPLICABILE MAX ADMISSIBLE DYNAMIC LOAD	[N]	3000*	2000*
C_{in,max}	PER AVERE $F_a = F_d$ TO GET	[Nm]	2,1	4,2
C_{m,max}	"CASO 1" / "CASE 1": B00 + D00/D01	[Nm]	2,1	4,2
	"CASO 3" / "CASE 3": B00 + R00/R01	[Nm]	2,3	4,6
			disponibile R=1 available R=1	
F_{st}	CARICO MASSIMO STATICO APPLICABILE MAX ADMISSIBLE STATIC LOAD	[N]	3400	3400
V_{out,max} N_{in,max}	VELOCITÀ DI TRASLAZIONE MASSIMA IN USCITA / ROTAZIONE MASSIMA VITE RDS MAX OUTPUT SPEED / MAX BALLSCREW ROTATING INPUT SPEED	[mm/sec] [rpm]	200 / 3000	600 / 3000
a_{max}	ACCELERAZIONE MASSIMA IN USCITA / MAX OUTPUT ACCELERATION	[m/sec ²]	1	2
S_{max}	CORSA MASSIMA STANDARD / MAX STANDARD STROKE	[mm]	500**	500**
	PESO MODULO BASE CORSA 0 mm / PESO OGNI 100 mm DI CORSA BASIC MODULE WEIGHT FOR 0 mm STROKE / WEIGHT FOR ADDITIONAL 100 mm STROKE	[Kg]	1,2 / 0,3	1,2 / 0,3
G_{s,max}	GIOCO ASSIALE MASSIMO PER CHIOCCIOLA STANDARD MAX AXIAL BACKLASH FOR STANDARD BALLSCREW ASSEMBLY	[mm]	0,02	0,02
G_z	GIOCO "0" DELLA CHIOCCIOLA / "0" BACKLASH BALLSCREW ASSEMBLY		NON DISPONIBILE / NOT AVAILABLE	
L_{10,Km}	DURATA / LIFETIME	[Km]	VEDI TABELLA / SEE TABLE	
	VERSIONI DISPONIBILI / AVAILABLE TYPES		D00/D01/R00/R01	D00/D01/R00/R01
	ACCESSORI DISPONIBILI / AVAILABLE ACCESSORIES		VEDI PARAGRAFO / SEE PARAGRAPH 3.10 (pg. 136)	

* Per le versioni R00/R01 controllare con il grafico di pagina 46. / For R00/R01 types please check graph at page 46.

** Per corse superiori, contattare il nostro servizio tecnico. / For longer strokes please contact our technical dpt.

3.2.2 Calcolo durata

3.2.2 Lifetime calculation

IE 40 P = 4 mm	$L_{10,Km} = \left[\frac{3370}{F_{eq}} \right]^3 \cdot 4$	$L_{10,Km} = [Km]$ $F_{eq} = [N]$
IE 40 P = 12 mm	$L_{10,Km} = \left[\frac{2200}{F_{eq}} \right]^3 \cdot 12$	$L_{10,Km} = [Km]$ $F_{eq} = [N]$

3.2.3 Calcolo coppia in ingresso al modulo base

3.2.3 Torque calculation at basic module input shaft

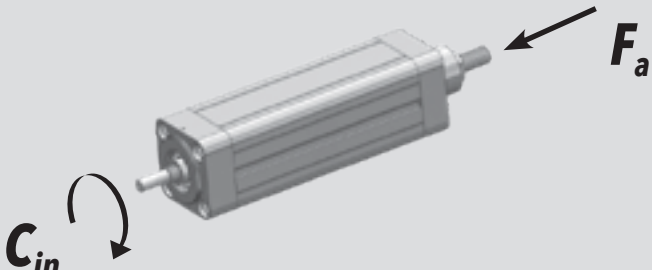
		
<p>IE 40 P = 4 mm</p>	$C_{in} = \left[\frac{F_a \cdot 4}{5652} \right]$	<p>$C_{in} = [Nm]$ $F_a = [N]$</p>
<p>IE 40 P = 12 mm</p>	$C_{in} = \left[\frac{F_a \cdot 12}{5652} \right]$	<p>$C_{in} = [Nm]$ $F_a = [N]$</p>

3.2.4 Calcolo coppia motore

3.2.4 Motor torque calculation

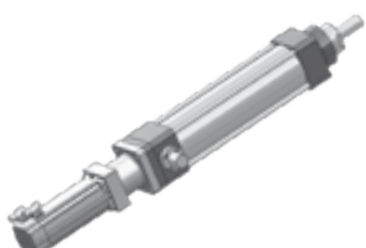
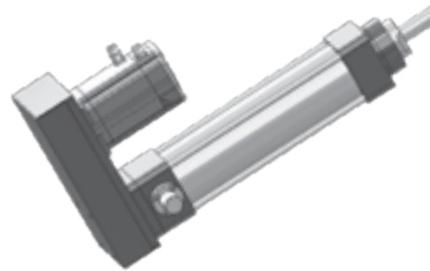
<p>CASO / CASE 1</p>	<p>ISOMOVE B00 + D00 / D01</p> 	$C_m = C_{in}$	<p>[Nm]</p>
<p>CASO / CASE 3</p>	<p>ISOMOVE B00 + R00 / R01</p> 	$C_m = \left[\frac{C_{in}}{R \cdot \eta} \right]$	<p>[Nm]</p>

R = rapporto di riduzione trasmissione a cinghia, disponibile R=1
 belt gearbox reduction ratio, available R=1
η = rendimento meccanico / mechanical efficiency = 0,90

3.2.5 Potenza in ingresso alla trasmissione a cinghia (versione R)

3.2.5 Mechanical input power at belt gear stage (R type)

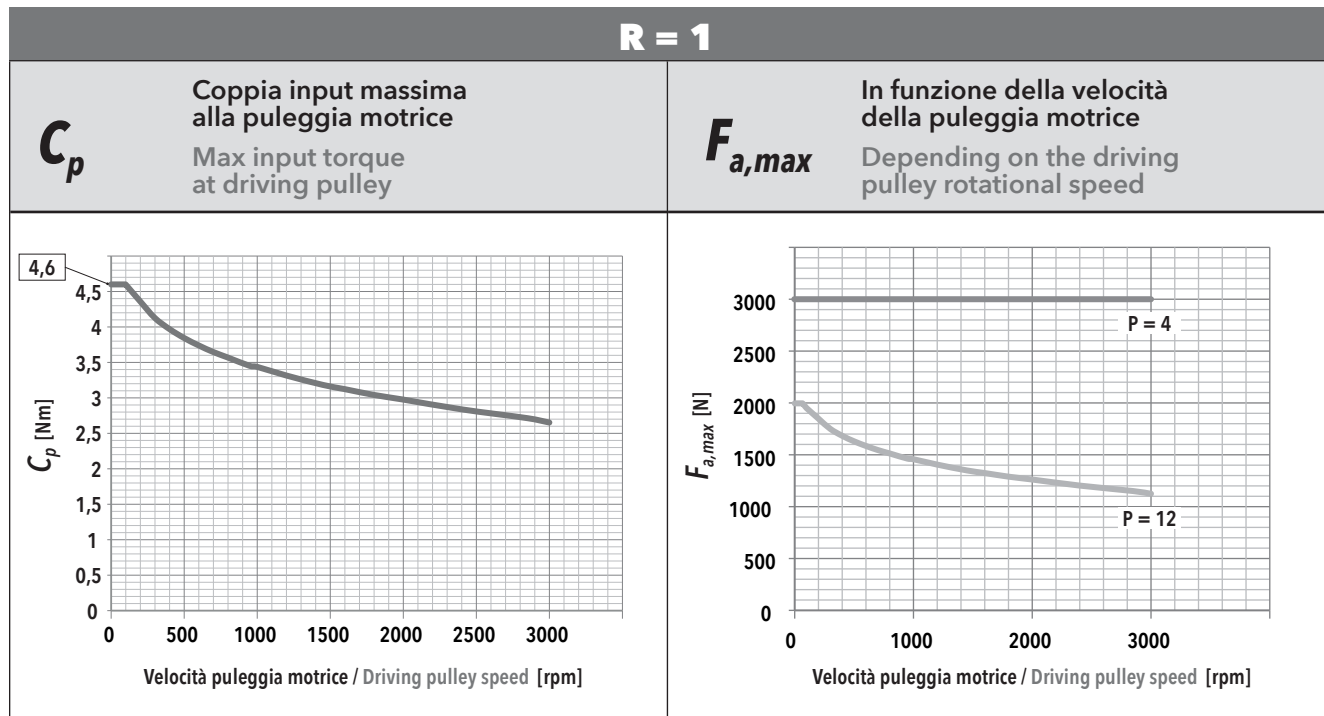

F_r Forza radiale su asse puleggia motrice in funzione di C_{in}
Radial force on driving pulley as a function of C_{in}

f_t Frequenza di vibrazione della cinghia per il tensionamento (al montaggio)
Vibration frequency of the belt for its tensioning (during assembly)

IE 40 - PASSO / PITCH 4					
F_a [N]		V_{out} [mm/s]			
		20	80	140	200
3000	F_r [N]	140	141	142	143
	f_t [Hz]	328	329	330	331
2700	F_r [N]	127	127	127	129
	f_t [Hz]	312	312	313	314
2400	F_r [N]	112	112	113	114
	f_t [Hz]	293	294	295	296
2100	F_r [N]	98	99	100	101
	f_t [Hz]	276	276	277	278
1800	F_r [N]	84	85	86	87
	f_t [Hz]	253	254	256	258
1500	F_r [N]	70	70	71	73
	f_t [Hz]	232	233	234	236
1200	F_r [N]	57	57	58	58
	f_t [Hz]	209	209	210	212
900	F_r [N]	41	42	43	44
	f_t [Hz]	179	180	182	184
600	F_r [N]	28	28	29	30
	f_t [Hz]	147	148	149	152
300	F_r [N]	13	14	15	16
	f_t [Hz]	101	105	108	111

IE 40 - PASSO / PITCH 12					
F_a [N]		V_{out} [mm/s]			
		60	240	420	600
2000	F_r [N]	282			
	f_t [Hz]	465			
1800	F_r [N]	253			
	f_t [Hz]	441			
1600	F_r [N]	225	226		
	f_t [Hz]	416	416		
1400	F_r [N]	197	197		
	f_t [Hz]	389	389		
1200	F_r [N]	169	169	170	
	f_t [Hz]	360	360	361	
1000	F_r [N]	141	141	142	143
	f_t [Hz]	329	329	330	331
800	F_r [N]	113	113	114	115
	f_t [Hz]	294	294	295	297
600	F_r [N]	85	85	86	87
	f_t [Hz]	255	255	256	258
400	F_r [N]	56	57	57	59
	f_t [Hz]	208	209	210	212
200	F_r [N]	28	29	29	30
	f_t [Hz]	147	148	150	153

3.2.6 Caratteristiche dimensionali

3.2.6 Overall dimensions

NOTA: Dati categorie motori / riduttori / rinvii al capitolo 4.

REMARK: Motors / Planetary / Angle bevel gearbox categories data at chapter 4.

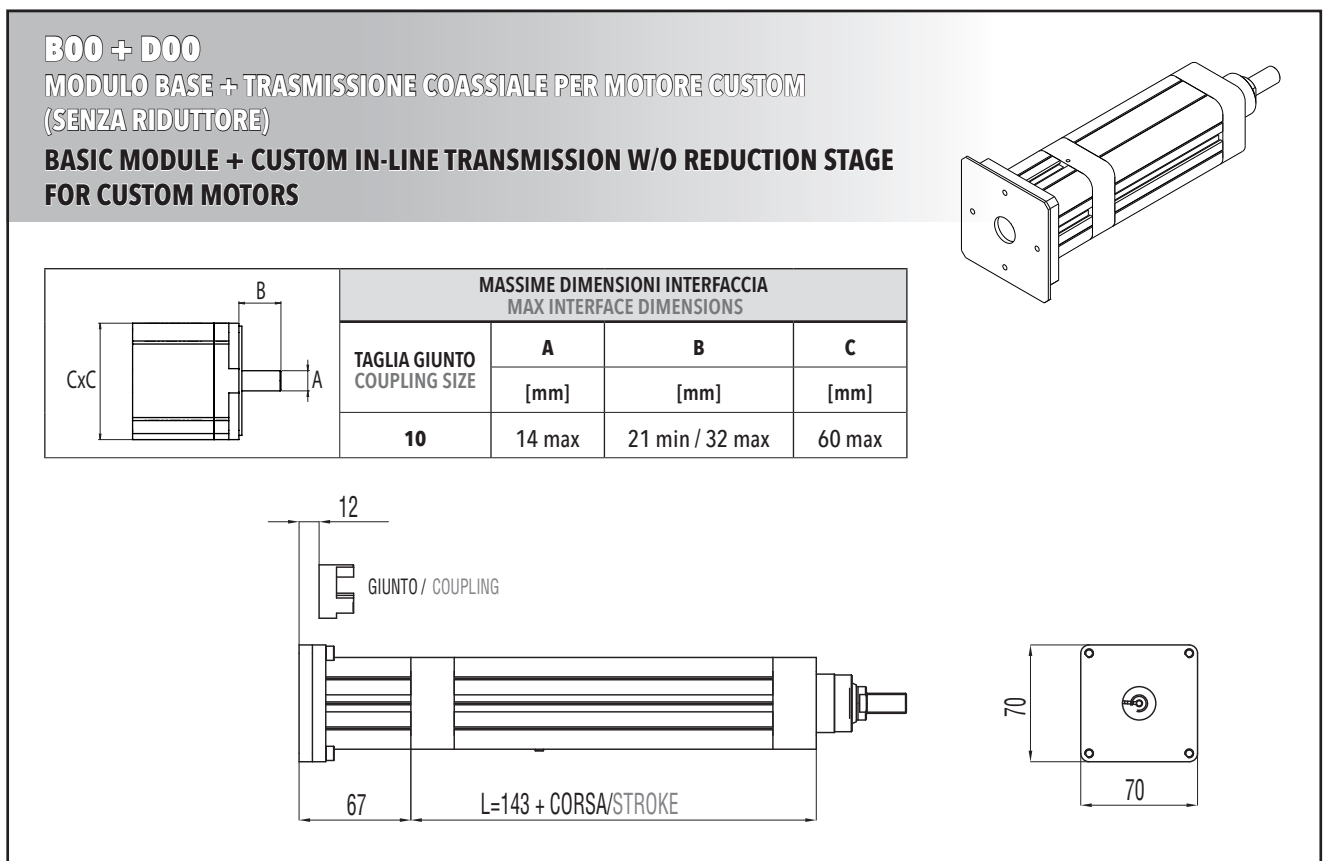
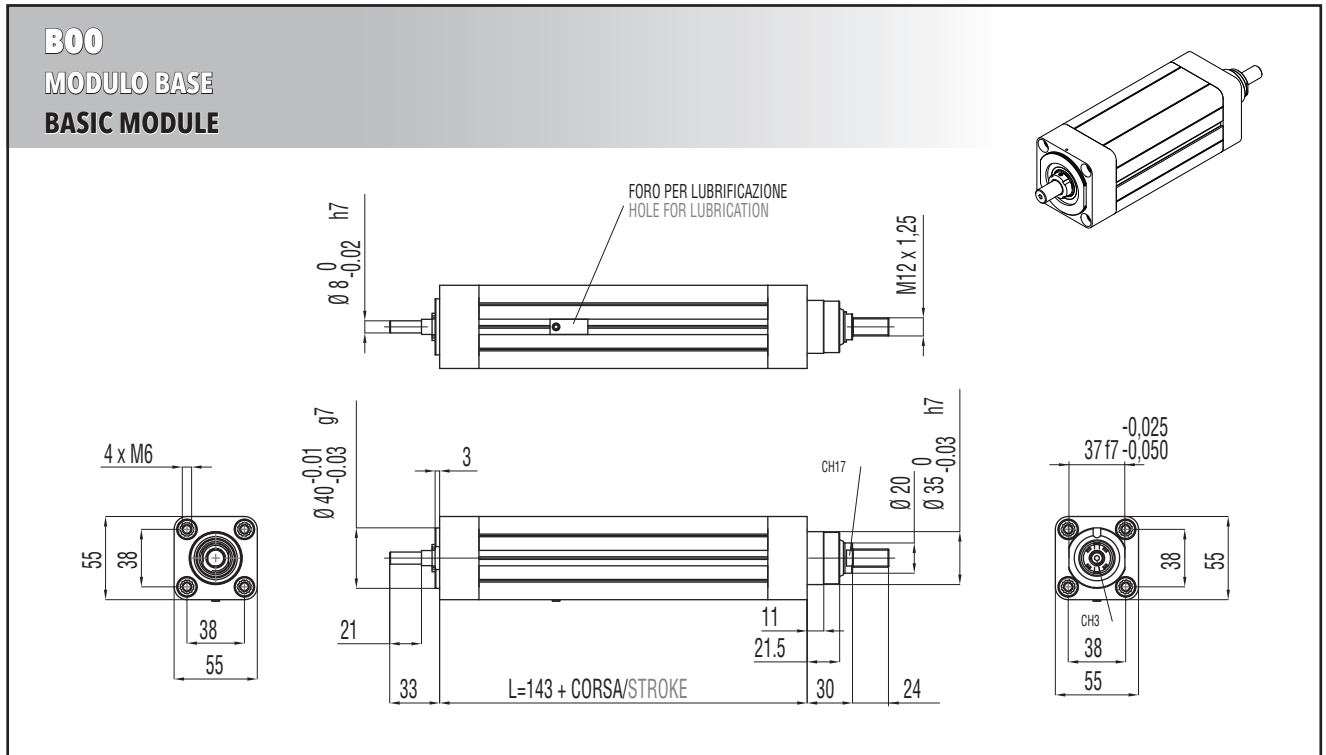

B00 + D01

MODULO BASE + TRASMISSIONE COASSIALE PER MOTORE COMPATIBILE
(SENZA RIDUTTORE)

BASIC MODULE + IN-LINE TRANSMISSION W/O REDUCTION STAGE FOR
COMPATIBLE MOTORS

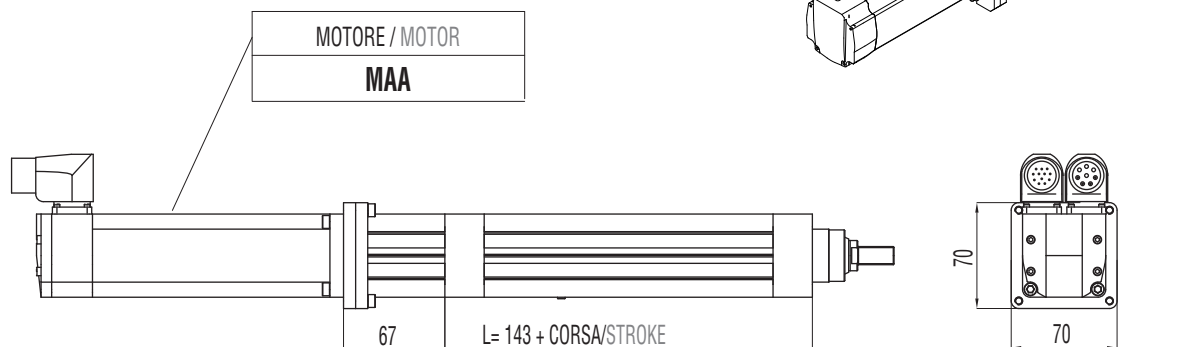

B00 + R00

MODULO BASE + TRASMISSIONE A CINGHIA IN PARALLELO PER MOTORE CUSTOM

BASIC MODULE + PARALLEL CUSTOM BELT GEARBOX STAGE FOR CUSTOM MOTORS

DIMENSIONI LIMITI INTERFACCIA MAX INTERFACE DIMENSIONS			
	A	B	C
	[mm]	[mm]	[mm]
R=1:1	14 max	24 min / 42 max	60 max

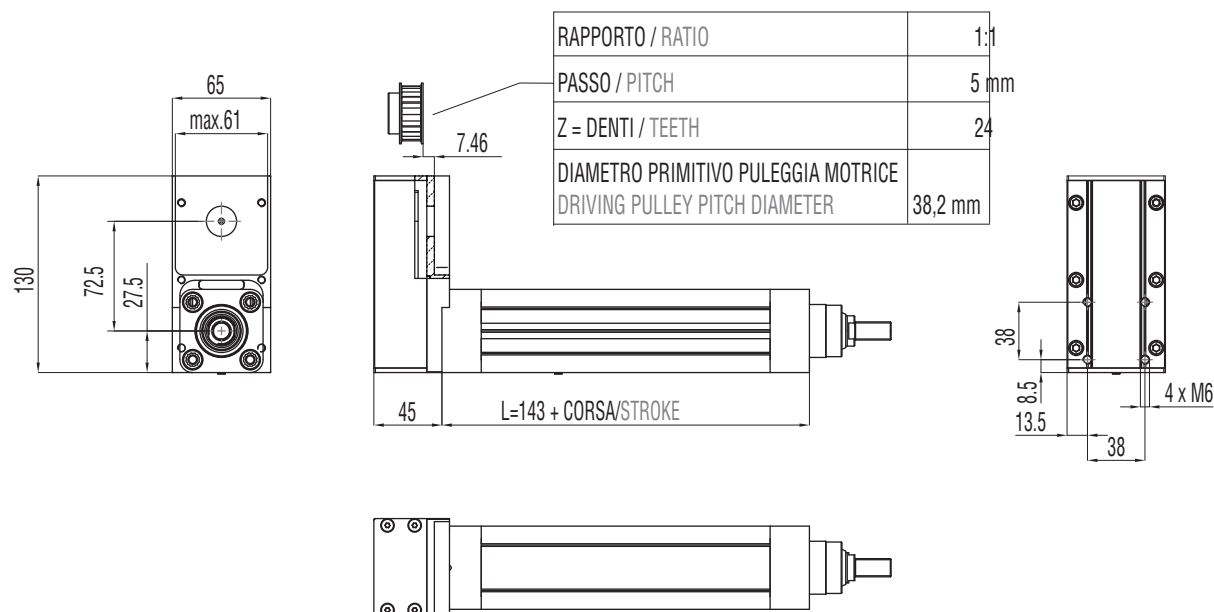

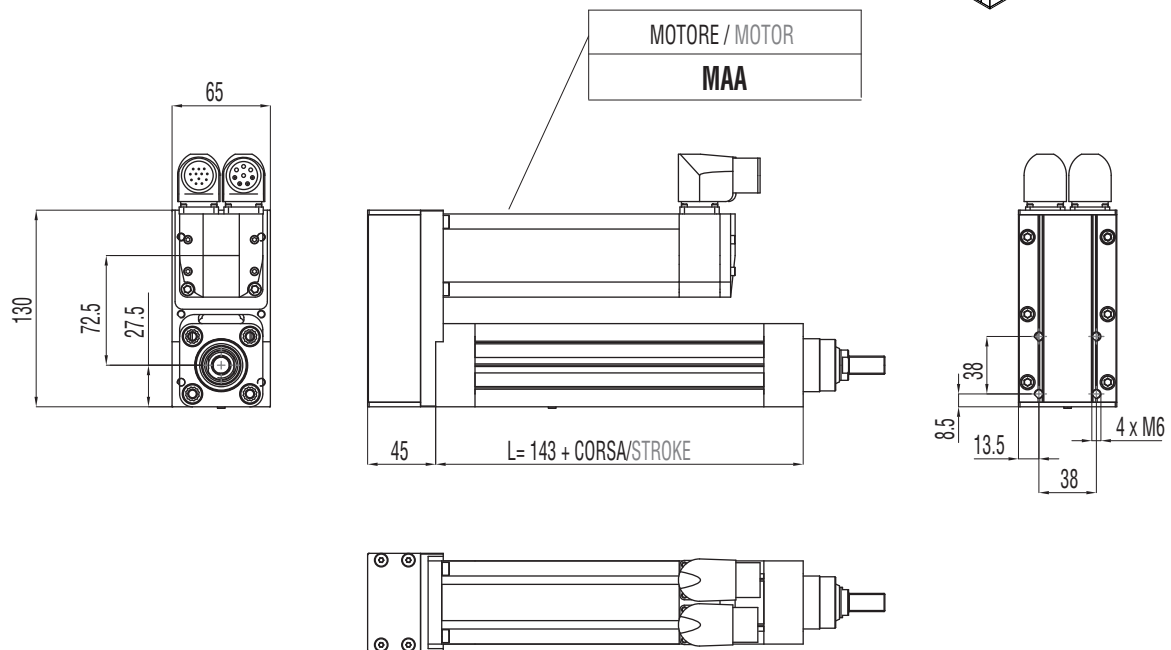
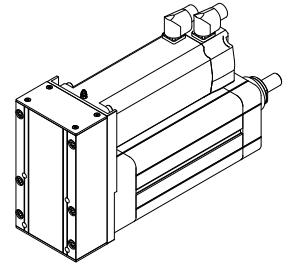
B00 + R01**MODULO BASE + TRASMISSIONE A CINGHIA IN PARALLELO PER MOTORE COMPATIBILE****BASIC MODULE + PARALLEL BELT GEARBOX STAGE FOR COMPATIBLE MOTORS****3.2.7 Accessori disponibili**

Per le tabelle e i disegni tecnici degli accessori disponibili fare riferimento al paragrafo 3.10 (da pag. 136).

3.2.7 Available accessories

For tables and drawings please refer to paragraph 3.10 (from page 136).

3.3

IE 50

3.3.1 Caratteristiche tecniche

3.3.1 Technical features





ISOMOVE IE 50		5	10	16
P	PASSO VITE SCREW LEAD [mm]	5	10	16
D	DIAMETRO VITE SCREW DIAMETER [mm]	16	16	16
F_d	CARICO MASSIMO DINAMICO APPLICABILE MAX ADMISSIBLE DYNAMIC LOAD [N]	4500*	4500*	4000*
C_{in,max}	PER AVERE $F_a = F_d$ TO GET [Nm]	3,9	7,9	11,3
	"CASO 1" / "CASE 1": B00 + D00/D01 [Nm]	3,9	7,9	11,3
	"CASO 2" / "CASE 2": B00 + D02/A01 [Nm]	$\left[\frac{4,3}{R} \right] + C_s$	$\left[\frac{8,7}{R} \right] + C_s$	$\left[\frac{12,5}{R} \right] + C_s$
		R = rapporto di riduzione del riduttore / rinvio angolare R = planetary / angle bevel gearbox reduction ratio		
C_{m,max}	"CASO 3" / "CASE 3": B00 + R00/R01 [Nm]	$\frac{4,3}{R}$	$\frac{8,7}{R}$	$\frac{12,5}{R}$
		R = rapporto di riduzione della trasmissione a cinghia (disponibile R=1 oppure R=2) R = belt gearbox reduction ratio (available R=1 or R=2)		
	"CASO 4" / "CASE 4": B00 + R02 [Nm]	$\frac{4,7}{R}$	$\frac{9,6}{R}$	$\frac{13,8}{R}$
		R = rapporto di riduzione del riduttore epicicloidale R = planetary gearbox reduction ratio		
F_{st}	CARICO MASSIMO STATICO APPLICABILE MAX ADMISSIBLE STATIC LOAD [N]	4500	4500	4500
V_{out,max}	VELOCITÀ DI TRASLAZIONE MASSIMA IN USCITA / ROTAZIONE MASSIMA VITE RDS [mm/sec]	250 / 3000	500 / 3000	800 / 3000
N_{in,max}	MAX OUTPUT SPEED / MAX BALLSCREW ROTATING INPUT SPEED [rpm]			
a_{max}	ACCELERAZIONE MASSIMA IN USCITA MAX OUTPUT ACCELERATION [m/sec ²]	1	2	2,5
S_{max}	CORSA MASSIMA STANDARD MAX STANDARD STROKE [mm]	700**	700**	700**
	PESO MODULO BASE CORSA 0 mm / PESO OGNI 100 mm DI CORSA BASIC MODULE WEIGHT FOR 0 mm STROKE / WEIGHT FOR ADDITIONAL 100 mm STROKE [Kg]	1,5 / 0,5	1,5 / 0,5	1,5 / 0,5
G_{s,max}	GIOCO ASSIALE MASSIMO PER CHIOCCIOLA STANDARD MAX AXIAL BACKLASH FOR STANDARD BALLSCREW ASSEMBLY mm	0,04	0,07	0,07
G_z	GIOCO "0" DELLA CHIOCCIOLA "0" BACKLASH BALLSCREW ASSEMBLY	DISPONIBILE / AVAILABLE		
L_{10,Km}	DURATA LIFETIME Km	VEDI TABELLA / SEE TABLE pg. 52		

* Per le versioni R00/R01 controllare con i grafici delle pagine 54/55. / For R00/R01 types please check graph at page 54/55.

** Per corse superiori, contattare il nostro servizio tecnico. / For longer strokes please contact our technical dept.

ISOMOVE IE 50		5	10	16
VERSIONI DISPONIBILI AVAILABLE TYPES		D00 / D01 / D02 / R00 / R01 / R02 / A01		
$F_{a,p}$	POSSIBILE CON IL RIDUTTORE EPICICLOIDALE INDICATO POSSIBLE VALUE WITH THE INDICATED PLANETARY GEARBOX	[N]	AE050/4500 PGII-060/4500	AE050/4500 PGII-060/4500 AE050/4500 PGII-060/4500
	POSSIBILE CON IL RINVIO ANGOLARE INDICATO POSSIBLE VALUE WITH THE INDICATED ANGLE BEVEL GEARBOX	[N]	ATB065/4500	ATB065/4500 ATB065/4500
ACCESSORI DISPONIBILI AVAILABLE ACCESSORIES		VEDI PARAGRAFO / SEE PARAGRAPH 3.10 (pg. 136)		

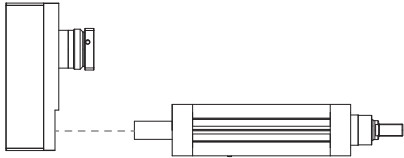
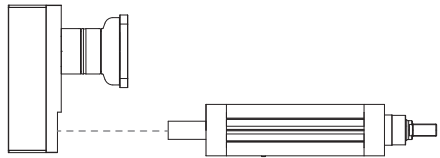
RIDUTTORI-RINVII "STANDARD SETEC GROUP DISPONIBILI"
"STANDARD SETEC GROUP AVAILABLE" PLANETARY-ANGLE BEVEL GEARBOXES

<p>TRASMISSIONE COASSIALE CON RIDUTTORE</p> <p>IN-LINE PLANETARY GEARBOX STAGE</p>	 <p>AE050</p> <p>MODULO BASE BASIC MODULE</p>	 <p>PGII-060</p> <p>MODULO BASE BASIC MODULE</p>
<p>TRASMISSIONE PARALLELA CON RIDUTTORE</p> <p>PARALLEL BELT GEARBOX STAGE + IN-LINE PLANETARY GEARBOX REDUCTION STAGE</p>	 <p>AE050</p> <p>MODULO BASE BASIC MODULE</p>	 <p>PGII-060</p> <p>MODULO BASE BASIC MODULE</p>
<p>TRASMISSIONE ANGOLARE CON RINVIO</p> <p>ANGLE BEVEL GEARBOX STAGE</p>	 <p>ATB065</p> <p>MODULO BASE BASIC MODULE</p>	

3.3.2 Calcolo durata

3.3.2 Lifetime calculation

<p>IE 50 P = 5 mm</p>	$L_{10,Km} = \left[\frac{6640}{F_{eq}} \right]^3 \cdot 5$	<p>$L_{10,Km} = [Km]$ $F_{eq} = [N]$</p>
<p>IE 50 P = 10 mm</p>	$L_{10,Km} = \left[\frac{6670}{F_{eq}} \right]^3 \cdot 10$	<p>$L_{10,Km} = [Km]$ $F_{eq} = [N]$</p>
<p>IE 50 P = 16 mm</p>	$L_{10,Km} = \left[\frac{4430}{F_{eq}} \right]^3 \cdot 16$	<p>$L_{10,Km} = [Km]$ $F_{eq} = [N]$</p>

3.3.3 Calcolo coppia in ingresso al modulo base

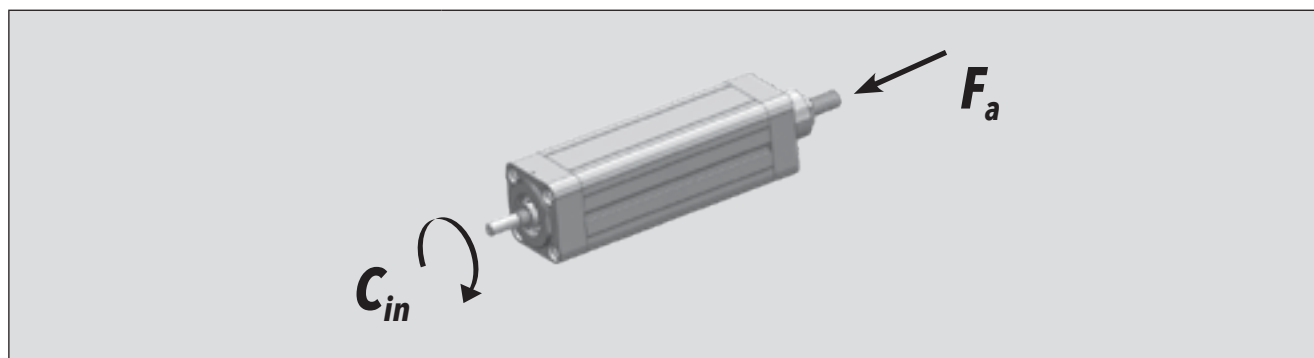

3.3.3 Torque calculation at basic module input shaft



<p>IE 50 P = 5 mm</p>	$C_{in} = \left[\frac{F_a \cdot 5}{5652} \right]$	<p>$C_{in} = [Nm]$ $F_a = [N]$</p>
<p>IE 50 P = 10 mm</p>	$C_{in} = \left[\frac{F_a \cdot 10}{5652} \right]$	<p>$C_{in} = [Nm]$ $F_a = [N]$</p>
<p>IE 50 P = 16 mm</p>	$C_{in} = \left[\frac{F_a \cdot 16}{5652} \right]$	<p>$C_{in} = [Nm]$ $F_a = [N]$</p>

3.3.4 Calcolo coppia motore

3.3.4 Motor torque calculation

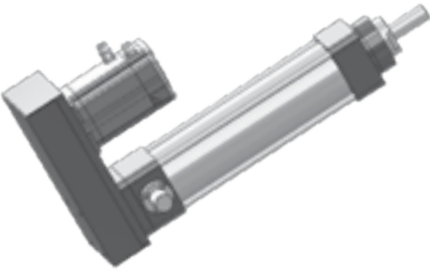
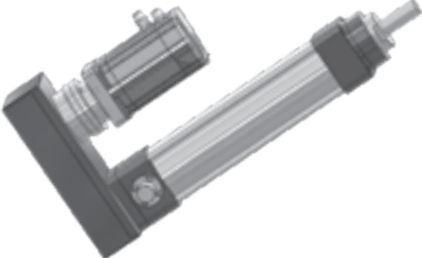
<p>CASO / CASE 1</p>	<p>ISOMOVE B00 + D00 / D01</p>  $C_m = C_{in} \quad [Nm]$
<p>CASO / CASE 2</p>	<p>ISOMOVE B00 + D02 / A01</p>  $C_m = \left[\frac{C_{in}}{R \cdot \eta} \right] + C_s \quad [Nm]$ <p>R = rapporto di riduzione riduttore / rinvio planetary / angle bevel gearbox reduction ratio η = rendimento meccanico / mechanical efficiency = 0,90</p>
<p>CASO / CASE 3</p>	<p>ISOMOVE B00 + R00 / R01</p>  $C_m = \left[\frac{C_{in}}{R \cdot \eta} \right] \quad [Nm]$ <p>R = rapporto di riduzione trasmissione a cinghia, disponibile R=1 o R=2 belt gearbox reduction ratio, available R=1 or R=2 η = rendimento meccanico / mechanical efficiency = 0,90</p>
<p>CASO / CASE 4</p>	<p>ISOMOVE B00 + R02</p>  $C_m = \left[\frac{C_{in}}{R \cdot \eta} \right] + C_s \quad [Nm]$ <p>R = rapporto di riduzione riduttore epicicloidale planetary gearbox reduction ratio η = rendimento meccanico / mechanical efficiency = 0,81</p>

3.3.5 Potenza in ingresso alla trasmissione a cinghia (versione R)

3.3.5 Mechanical input power at belt gear stage (R type)

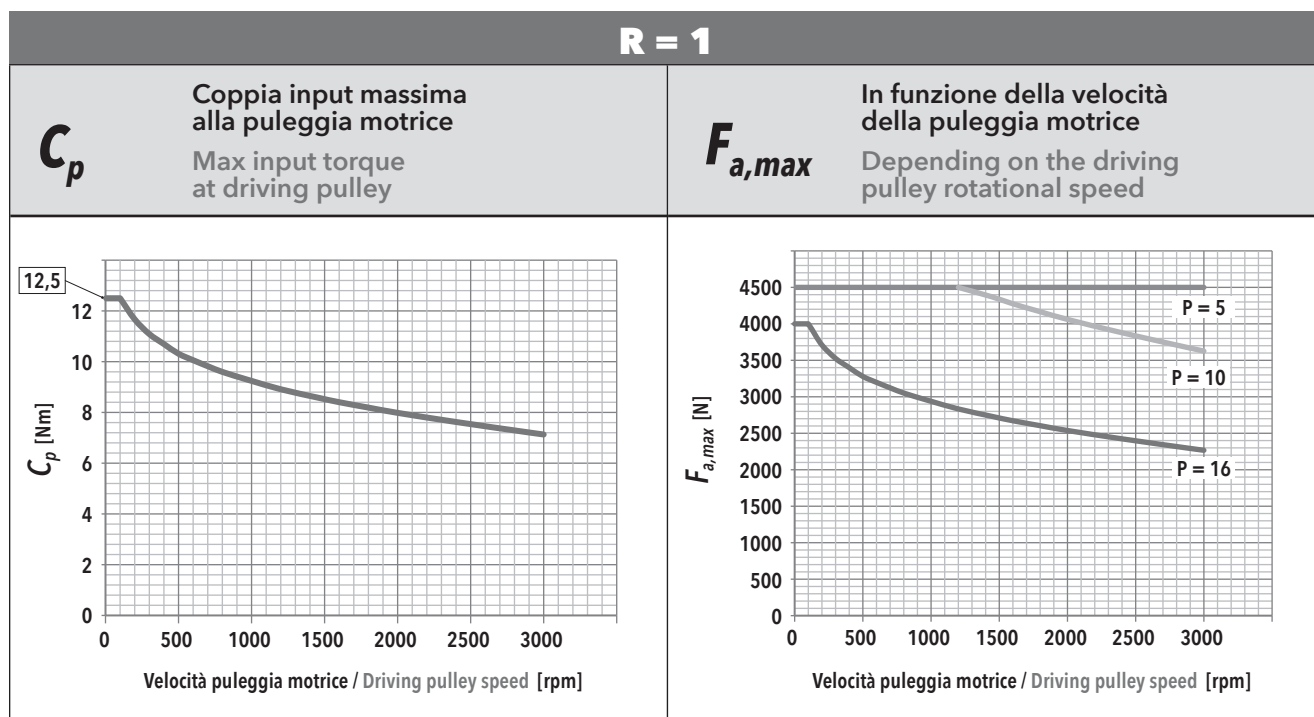

F_r Forza radiale su asse puleggia motrice in funzione di C_{in}
Radial force on driving pulley as a function of C_{in}

f_t Frequenza di vibrazione della cinghia per il tensionamento (al montaggio)
Vibration frequency of the belt for its tensioning (during assembly)

IE 50 - PASSO / PITCH 5					IE 50 - PASSO / PITCH 10					IE 50 - PASSO / PITCH 16							
F_a [N]		V_{out} [mm/s]				F_a [N]		V_{out} [mm/s]				F_a [N]		V_{out} [mm/s]			
		25	100	175	250			50	200	350	500			80	320	560	800
4500	F_r [N]	211	212	214	217	4500	F_r [N]	422				4000	F_r [N]	601			
	f_t [Hz]	226	227	228	229		f_t [Hz]	320					f_t [Hz]	382			
4050	F_r [N]	190	191	193	196	4050	F_r [N]	380	381			3600	F_r [N]	541	542		
	f_t [Hz]	215	215	216	218		f_t [Hz]	304	304				f_t [Hz]	362	362		
3600	F_r [N]	169	170	172	175	3600	F_r [N]	338	339	341		3200	F_r [N]	481	482		
	f_t [Hz]	202	203	204	206		f_t [Hz]	286	287	287			f_t [Hz]	341	342		
3150	F_r [N]	148	149	151	154	3150	F_r [N]	296	297	299	301	2800	F_r [N]	421	421	423	
	f_t [Hz]	189	190	191	193		f_t [Hz]	268	268	269	270		f_t [Hz]	319	320	320	
2700	F_r [N]	127	128	130	133	2700	F_r [N]	254	254	256	259	2400	F_r [N]	361	361	363	366
	f_t [Hz]	175	176	177	179		f_t [Hz]	248	248	249	251		f_t [Hz]	296	296	297	298
2250	F_r [N]	106	107	108	111	2250	F_r [N]	211	212	214	217	2000	F_r [N]	300	301	303	306
	f_t [Hz]	160	161	162	164		f_t [Hz]	226	227	228	229		f_t [Hz]	270	270	271	272
1800	F_r [N]	85	85	87	90	1800	F_r [N]	169	170	172	175	1600	F_r [N]	240	241	243	246
	f_t [Hz]	143	144	145	148		f_t [Hz]	202	203	204	206		f_t [Hz]	241	242	243	244
1350	F_r [N]	63	64	66	69	1350	F_r [N]	127	128	130	133	1200	F_r [N]	180	181	183	186
	f_t [Hz]	124	125	127	129		f_t [Hz]	175	176	177	179		f_t [Hz]	209	210	211	212
900	F_r [N]	42	43	45	48	900	F_r [N]	85	85	87	90	800	F_r [N]	120	121	123	126
	f_t [Hz]	101	102	105	108		f_t [Hz]	143	144	145	148		f_t [Hz]	171	171	173	175
450	F_r [N]	21	22	24	27	450	F_r [N]	42	43	45	48	400	F_r [N]	60	61	63	66
	f_t [Hz]	72	73	76	81		f_t [Hz]	101	102	105	108		f_t [Hz]	121	122	123	126

R = 2

C_p Coppia input massima alla puleggia motrice
Max input torque at driving pulley

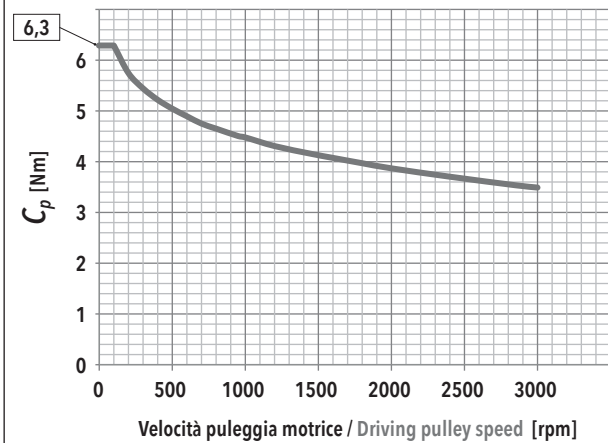

$F_{a,max}$ In funzione della velocità della puleggia motrice
Depending on the driving pulley rotational speed

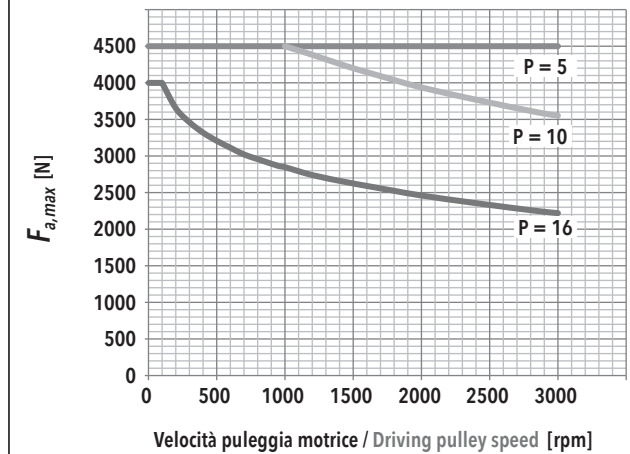

F_r Forza radiale su asse puleggia motrice in funzione di C_{in}
Radial force on driving pulley as a function of C_{in}

f_t Frequenza di vibrazione della cinghia per il tensionamento (al montaggio)
Vibration frequency of the belt for its tensioning (during assembly)

IE 50 - PASSO / PITCH 5					IE 50 - PASSO / PITCH 10					IE 50 - PASSO / PITCH 16							
F_a [N]		V_{out} [mm/s]				F_a [N]		V_{out} [mm/s]				F_a [N]		V_{out} [mm/s]			
		12,5	50	87,5	125			25	100	175	250			40	160	280	400
4500	F_r [N]	182	182	183	184	4500	F_r [N]	364	364			4000	F_r [N]				
	f_t [Hz]	200	200	200	201		f_t [Hz]	283	283				f_t [Hz]				
4050	F_r [N]	164	164	165	166	4050	F_r [N]	328	328	329		3600	F_r [N]				
	f_t [Hz]	190	190	190	191		f_t [Hz]	268	268	268			f_t [Hz]				
3600	F_r [N]	146	146	147	148	3600	F_r [N]	291	291	292	293	3200	F_r [N]	414			
	f_t [Hz]	179	179	179	180		f_t [Hz]	253	253	254	254		f_t [Hz]	301			
3150	F_r [N]	127	128	129	130	3150	F_r [N]	255	255	256	257	2800	F_r [N]	363	363		
	f_t [Hz]	167	167	168	169		f_t [Hz]	236	236	237	237		f_t [Hz]	282	282		
2700	F_r [N]	109	109	110	111	2700	F_r [N]	218	218	219	221	2400	F_r [N]	311	311	312	
	f_t [Hz]	155	155	156	156		f_t [Hz]	219	219	220	220		f_t [Hz]	261	261	262	
2250	F_r [N]	91	92	92	93	2250	F_r [N]	182	182	184	184	2000	F_r [N]	259	259	261	261
	f_t [Hz]	141	141	142	143		f_t [Hz]	200	200	201	201		f_t [Hz]	238	238	239	239
1800	F_r [N]	73	73	74	75	1800	F_r [N]	146	147	148	148	1600	F_r [N]	207	207	209	209
	f_t [Hz]	126	127	127	128		f_t [Hz]	179	179	180	180		f_t [Hz]	213	214	214	214
1350	F_r [N]	55	55	56	57	1350	F_r [N]	109	110	111	111	1200	F_r [N]	155	155	157	157
	f_t [Hz]	109	110	111	112		f_t [Hz]	155	154	156	156		f_t [Hz]	185	185	186	186
900	F_r [N]	36	37	37	38	900	F_r [N]	73	73	75	75	800	F_r [N]	104	105	106	106
	f_t [Hz]	89	89	90	92		f_t [Hz]	126	126	128	128		f_t [Hz]	151	151	152	152
450	F_r [N]	18	19	20	20	450	F_r [N]	36	36	37	38	400	F_r [N]	52	53	54	54
	f_t [Hz]	63	64	65	67		f_t [Hz]	89	89	90	92		f_t [Hz]	107	108	109	109

3.3.6 Caratteristiche dimensionali

3.3.6 Overall dimensions

NOTA: Dati categorie motori / riduttori / rinvii al capitolo 4.

REMARK: Motors / Planetary / Angle bevel gearbox categories data at chapter 4.

B00
MODULO BASE
BASIC MODULE

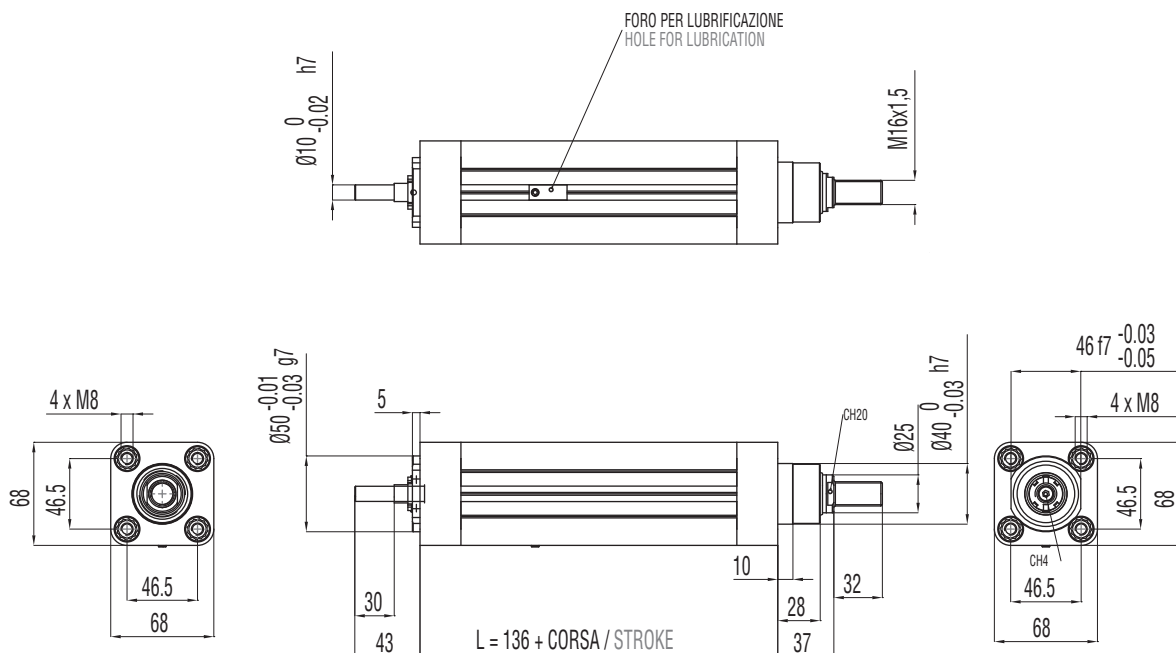
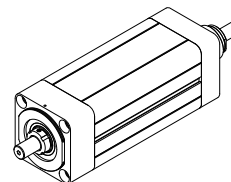

B00 + D00

MODULO BASE + TRASMISSIONE COASSIALE PER MOTORE CUSTOM
(SENZA RIDUTTORE)

**BASIC MODULE + CUSTOM IN-LINE TRANSMISSION W/O REDUCTION STAGE
FOR CUSTOM MOTORS**

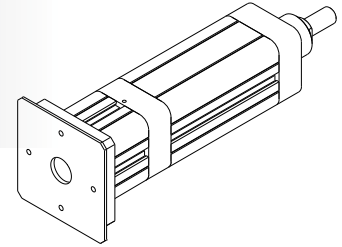

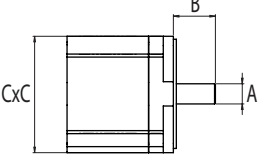
	MASSIME DIMENSIONI INTERFACCIA MAX INTERFACE DIMENSIONS			
	TAGLIA GIUNTO COUPLING SIZE	A [mm]	B [mm]	C [mm]
	20	22 max	28 min / 40 max	100 max

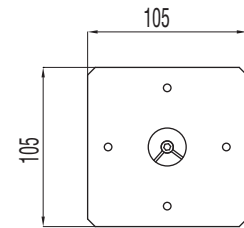
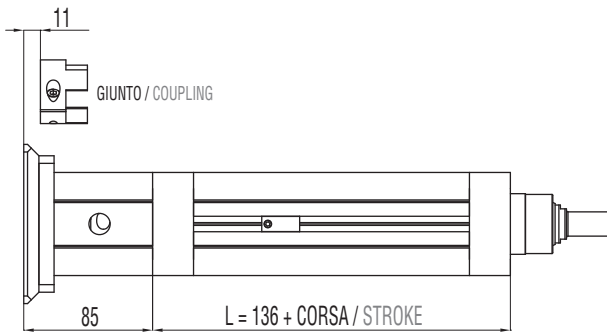

B00 + D01

MODULO BASE + TRASMISSIONE COASSIALE PER MOTORE COMPATIBILE
(SENZA RIDUTTORE)

**BASIC MODULE + IN-LINE TRANSMISSION W/O REDUCTION STAGE FOR
COMPATIBLE MOTORS**

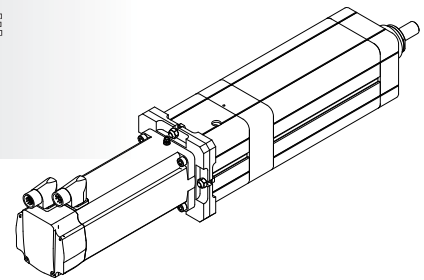

- | |
|------------|
| MOTORE |
| MOTOR |
| MCA |
| MCB |
| MCC |
| MCD |
| MDA |
| MDB |
| MDC |

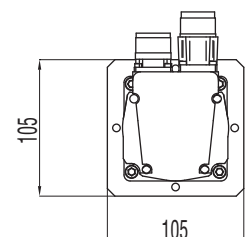
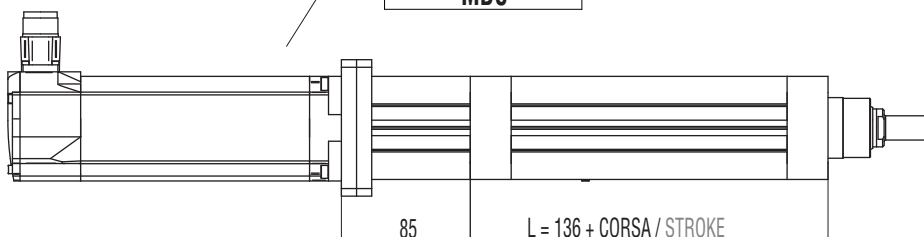

B00 + D02

MODULO BASE + RIDUTTORE EPICICLOIDALE COASSIALE COMPATIBILE

BASIC MODULE + IN-LINE COMPATIBLE PLANETARY GEARBOX REDUCTION STAGE

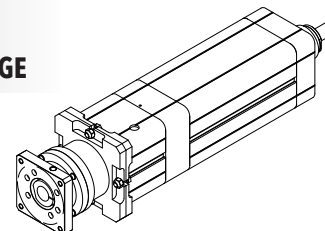

RIDUTTORE
PLANETARY GEARBOX
GBA
GBB

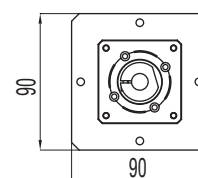
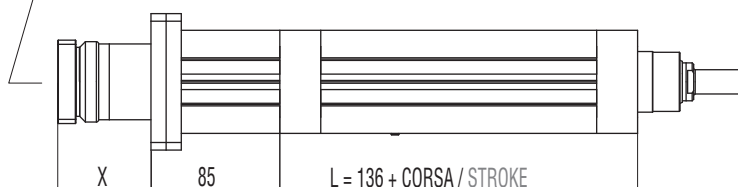

B00 + A01

MODULO BASE + RINVIO ANGOLARE COMPATIBILE

BASIC MODULE + COMPATIBLE ANGLE BEVEL GEARBOX STAGE

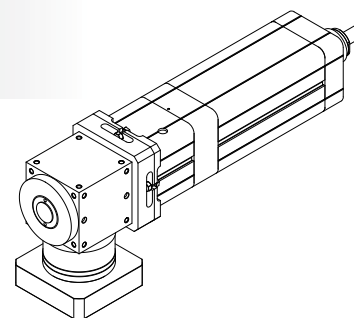

RINVIO
BEVEL GEARBOX
AAA

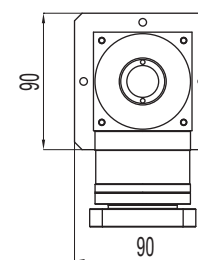
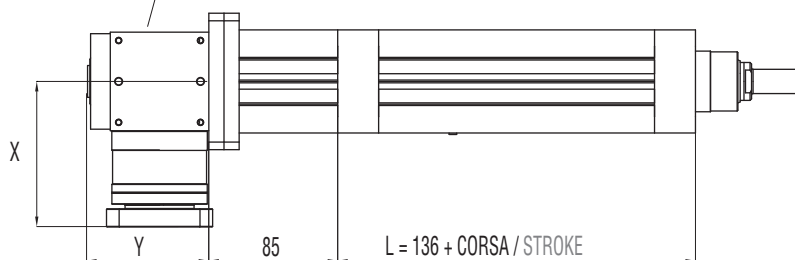

B00 + R00

MODULO BASE + TRASMISSIONE A CINGHIA IN PARALLELO PER MOTORE CUSTOM

BASIC MODULE + PARALLEL CUSTOM BELT GEARBOX STAGE FOR CUSTOM MOTORS

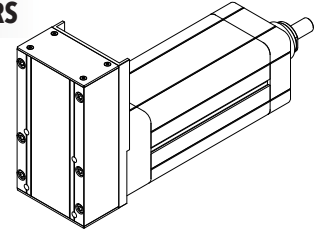

	DIMENSIONI LIMITI INTERFACCIA MAX INTERFACE DIMENSIONS		
	A	B	C
	[mm]	[mm]	[mm]
R=1:1	16 max	28 min / 42 max	100 max
R=1:2	13 max	30 min / 40 max	100 max

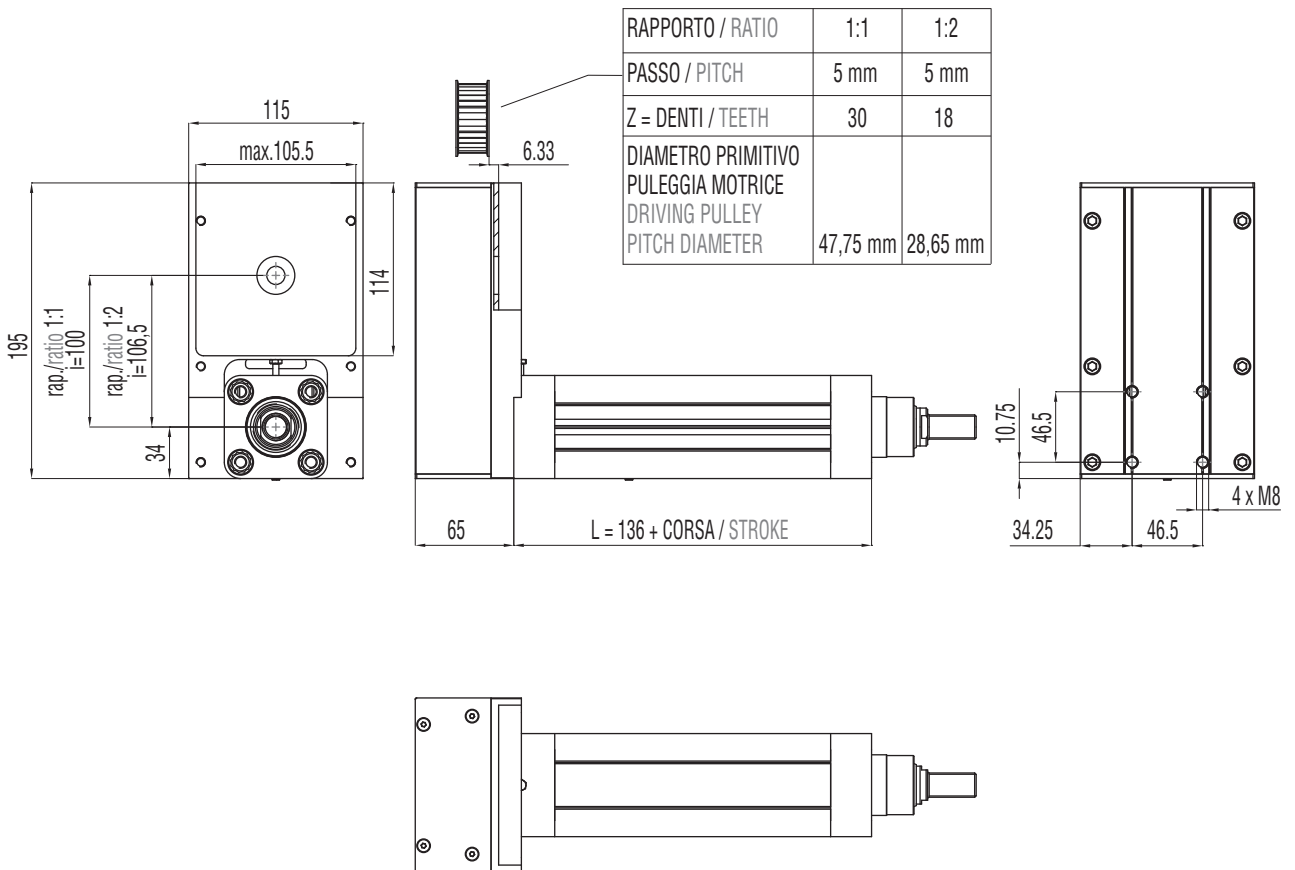

B00 + R01

MODULO BASE + TRASMISSIONE A CINGHIA IN PARALLELO PER MOTORE COMPATIBILE

BASIC MODULE + PARALLEL BELT GEARBOX STAGE FOR COMPATIBLE MOTORS

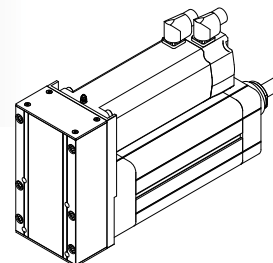

MOTORE
MOTOR
MCA
MCB
MCC
MCD
MDA
MDB
MDC

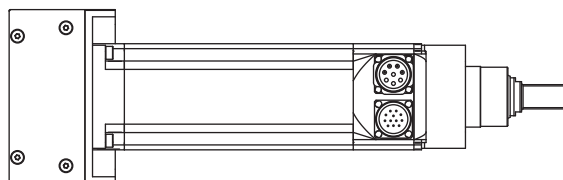
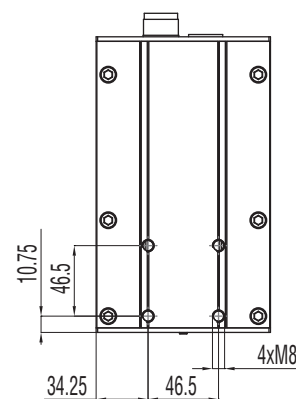
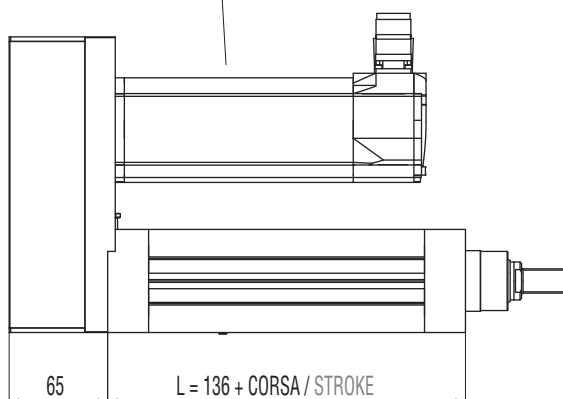
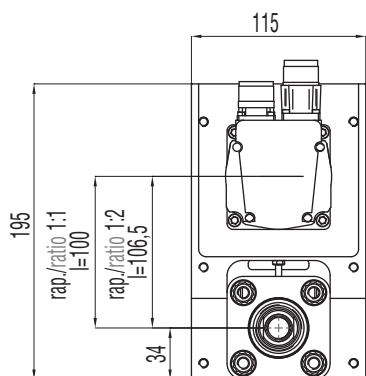

B00 + R02

MODULO BASE + TRASMISSIONE A CINGHIA IN PARALLELO +
RIDUTTORE EPICICLOIDALE COMPATIBILE

**BASIC MODULE + PARALLEL BELT GEARBOX STAGE +
IN-LINE COMPATIBLE PLANETARY GEARBOX REDUCTION STAGE**

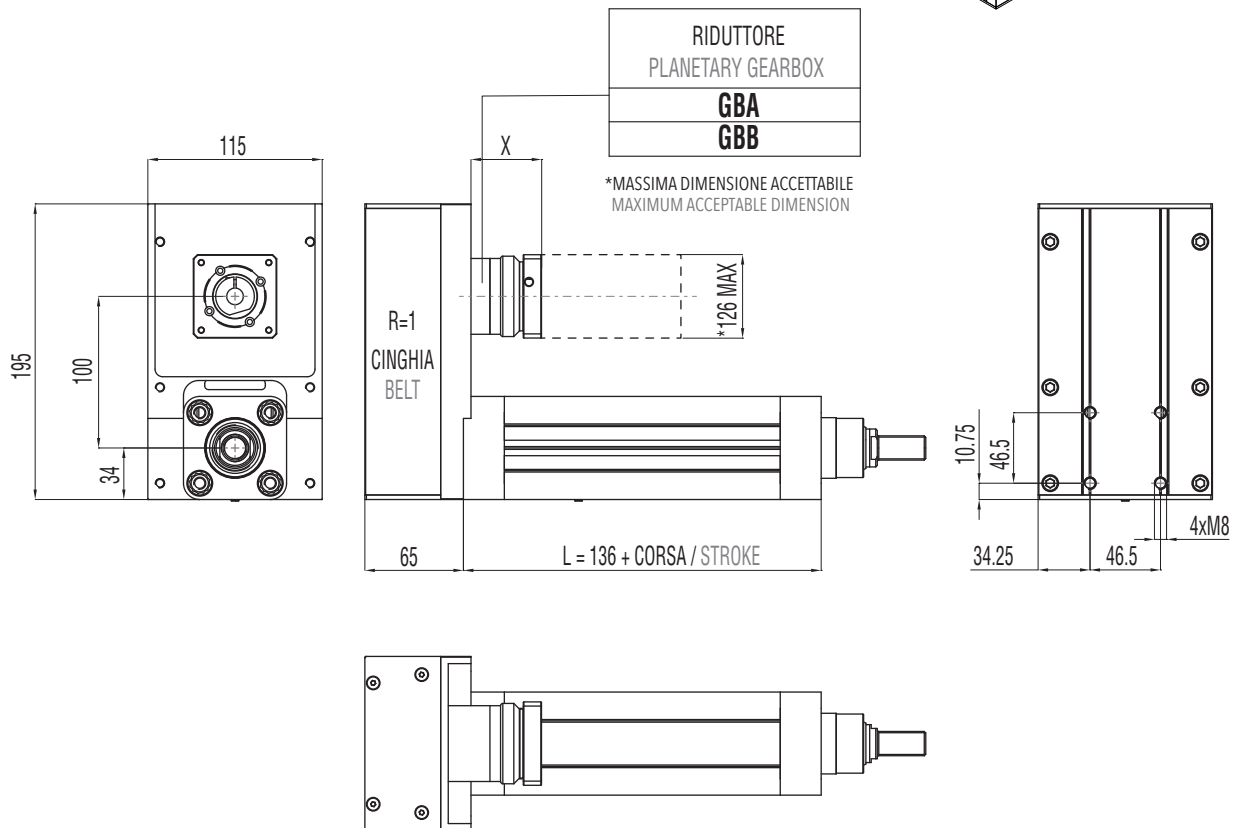
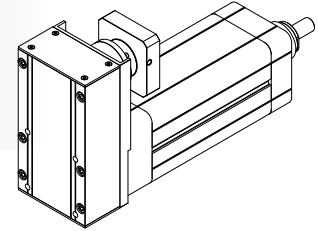

3.3.7 Accessori disponibili

Per le tabelle e i disegni tecnici degli accessori disponibili fare riferimento al paragrafo 3.10 (da pag. 136).

3.3.7 Available accessories

For tables and drawings please refer to paragraph 3.10 (from page 136).

3.4

IE 63

3.4.1 Caratteristiche tecniche

3.4.1 Technical features

ISOMOVE IE 63		5	10	20
P	PASSO VITE SCREW LEAD [mm]	5	10	20
D	DIAMETRO VITE SCREW DIAMETER [mm]	20	20	20
F_d	CARICO MASSIMO DINAMICO APPLICABILE MAX ADMISSIBLE DYNAMIC LOAD [N]	7500*	7500*	7500*
C_{in,max}	PER AVERE $F_a = F_d$ TO GET [Nm]	6,6	12,2	26,5
	"CASO 1" / "CASE 1": B00 + D00/D01 [Nm]	6,6	12,2	26,5
	"CASO 2" / "CASE 2": B00 + D02/A01 [Nm]	$\left[\frac{7,3}{R} \right] + C_s$	$\left[\frac{13,5}{R} \right] + C_s$	$\left[\frac{29,4}{R} \right] + C_s$
		R = rapporto di riduzione del riduttore / rinvio angolare R = planetary / angle bevel gearbox reduction ratio		
C_{m,max}	"CASO 3" / "CASE 3": B00 + R00/R01 [Nm]	$\frac{7,3}{R}$	$\frac{13,5}{R}$	$\frac{29,4}{R}$
		R = rapporto di riduzione della trasmissione a cinghia (disponibile R=1 oppure R=2) R = belt gearbox reduction ratio (available R=1 or R=2)		
	"CASO 4" / "CASE 4": B00 + R02 [Nm]	$\frac{8,1}{R}$	$\frac{15}{R}$	$\frac{32,6}{R}$
		R = rapporto di riduzione del riduttore epicicloidale R = planetary gearbox reduction ratio		
F_{st}	CARICO MASSIMO STATICO APPLICABILE MAX ADMISSIBLE STATIC LOAD [N]	7500	7500	7500
V_{out,max}	VELOCITÀ DI TRASLAZIONE MASSIMA IN USCITA / ROTAZIONE MASSIMA VITE RDS [mm/sec]	250/3000	500/3000	1000/3000
N_{in,max}	MAX OUTPUT SPEED / MAX BALLSCREW ROTATING INPUT SPEED [rpm]			
a_{max}	ACCELERAZIONE MASSIMA IN USCITA MAX OUTPUT ACCELERATION [m/sec ²]	1	2	3
S_{max}	CORSA MASSIMA STANDARD MAX STANDARD STROKE [mm]	800**	800**	800**
	PESO MODULO BASE CORSA 0 mm / PESO OGNI 100 mm DI CORSA BASIC MODULE WEIGHT FOR 0 mm STROKE / WEIGHT FOR ADDITIONAL 100 mm STROKE [Kg]	2,6 / 0,8	2,6 / 0,8	2,6 / 0,8
G_{s,max}	GIOCO ASSIALE MASSIMO PER CHIOCCIOLA STANDARD MAX AXIAL BACKLASH FOR STANDARD BALLSCREW ASSEMBLY mm	0,06	0,02	0,06
G_z	GIOCO "0" DELLA CHIOCCIOLA "0" BACKLASH BALLSCREW ASSEMBLY	DISPONIBILE / AVAILABLE		
L_{10,Km}	DURATA LIFETIME Km	VEDI TABELLA / SEE TABLE pag. 64		







* Per le versioni R00/R01 controllare con i grafici delle pagine 66/67. / For R00/R01 types please check graph at pages 66/67.

** Per corse superiori, contattare il nostro servizio tecnico. / For longer strokes please contact our technical dpt.

ISOMOVE IE 63		5	10	20	
VERSIONI DISPONIBILI AVAILABLE TYPES		D00 / D01 / D02 / R00 / R01 / R02 / A01			
$F_{a,p}$	POSSIBILE CON IL RIDUTTORE EPICICLOIDALE INDICATO POSSIBLE VALUE WITH THE INDICATED PLANETARY GEARBOX	[N]	AE070/7500 PGII-060/7500 PGII-080/7500	AE070/7500 PGII-060/7500 PGII-080/7500	AE070/7500 PGII-060/5700*** PGII-080/7500
	POSSIBILE CON IL RINVIO ANGOLARE INDICATO POSSIBLE VALUE WITH THE INDICATED ANGLE BEVEL GEARBOX	[N]	ATB075/7500	ATB075/4500	ATB065/7500
ACCESSORI DISPONIBILI AVAILABLE ACCESSORIES		VEDI PARAGRAFO / SEE PARAGRAPH 3.10 (pg. 136)			

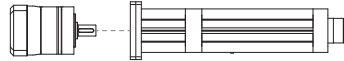
*** È il valore massimo ottenibile con il rapporto di riduzione disponibile avente il minore valore di coppia erogabile.
It is the max obtainable value with the available on tables reduction ratio which has the lowest value of nominal output torque.

RIDUTTORI-RINVII "STANDARD SETEC GROUP DISPONIBILI"
"STANDARD SETEC GROUP AVAILABLE" PLANETARY-ANGLE BEVEL GEARBOXES

<p>TRASMISSIONE COASSIALE CON RIDUTTORE</p> <p>IN-LINE PLANETARY GEARBOX STAGE</p>	 <p>AE070</p> <p>MODULO BASE BASIC MODULE</p>	 <p>PGII-060</p> <p>MODULO BASE BASIC MODULE</p>	 <p>PGII-080</p> <p>MODULO BASE BASIC MODULE</p>
<p>TRASMISSIONE PARALLELA CON RIDUTTORE</p> <p>PARALLEL BELT GEARBOX STAGE + IN-LINE PLANETARY GEARBOX REDUCTION STAGE</p>	 <p>AE070</p> <p>MODULO BASE BASIC MODULE</p>	 <p>PGII-060</p> <p>MODULO BASE BASIC MODULE</p>	 <p>PGII-080</p> <p>MODULO BASE BASIC MODULE</p>
<p>TRASMISSIONE ANGOLARE CON RINVIO</p> <p>ANGLE BEVEL GEARBOX STAGE</p>	 <p>ATB075</p> <p>MODULO BASE BASIC MODULE</p>		

3.4.2 Calcolo durata

3.4.2 Lifetime calculation

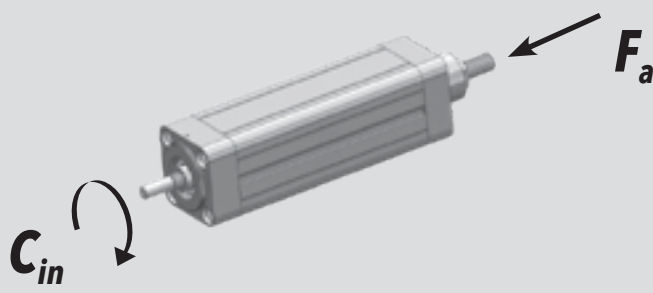

IE 63 P = 5 mm	$L_{10,Km} = \left[\frac{12100}{F_{eq}} \right]^3 \cdot 5$	$L_{10,Km} = [Km]$ $F_{eq} = [N]$
IE 63 P = 10 mm	$L_{10,Km} = \left[\frac{9910}{F_{eq}} \right]^3 \cdot 10$	$L_{10,Km} = [Km]$ $F_{eq} = [N]$
IE 63 P = 20 mm	$L_{10,Km} = \left[\frac{14700}{F_{eq}} \right]^3 \cdot 20$	$L_{10,Km} = [Km]$ $F_{eq} = [N]$

3.4.3 Calcolo coppia in ingresso
al modulo base3.4.3 Torque calculation at basic
module input shaft

		
IE 63 P = 5 mm	$C_{in} = \left[\frac{F_a \cdot 5}{5652} \right]$	$C_{in} = [Nm]$ $F_a = [N]$
IE 63 P = 10 mm	$C_{in} = \left[\frac{F_a \cdot 10}{5652} \right]$	$C_{in} = [Nm]$ $F_a = [N]$
IE 63 P = 20 mm	$C_{in} = \left[\frac{F_a \cdot 20}{5652} \right]$	$C_{in} = [Nm]$ $F_a = [N]$

3.4.4 Calcolo coppia motore

3.4.4 Motor torque calculation

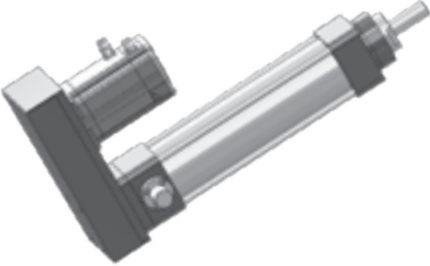
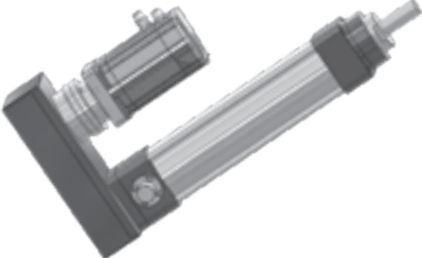
<p>CASO / CASE</p> <p>1</p>	<p>ISOMOVE B00 + D00 / D01</p>  $C_m = C_{in} \quad [Nm]$
<p>CASO / CASE</p> <p>2</p>	<p>ISOMOVE B00 + D02 / A01</p>  $C_m = \left[\frac{C_{in}}{R \cdot \eta} \right] + C_s \quad [Nm]$ <p>R = rapporto di riduzione riduttore / rinvio planetary / angle bevel gearbox reduction ratio η = rendimento meccanico / mechanical efficiency = 0,90</p>
<p>CASO / CASE</p> <p>3</p>	<p>ISOMOVE B00 + R00 / R01</p>  $C_m = \left[\frac{C_{in}}{R \cdot \eta} \right] \quad [Nm]$ <p>R = rapporto di riduzione trasmissione a cinghia, disponibile R=1 o R=2 belt gearbox reduction ratio, available R=1 or R=2 η = rendimento meccanico / mechanical efficiency = 0,90</p>
<p>CASO / CASE</p> <p>4</p>	<p>ISOMOVE B00 + R02</p>  $C_m = \left[\frac{C_{in}}{R \cdot \eta} \right] + C_s \quad [Nm]$ <p>R = rapporto di riduzione riduttore epicicloidale planetary gearbox reduction ratio η = rendimento meccanico / mechanical efficiency = 0,81</p>

3.4.5 Potenza in ingresso alla trasmissione a cinghia (versione R)

3.4.5 Mechanical input power at belt gear stage (R type)

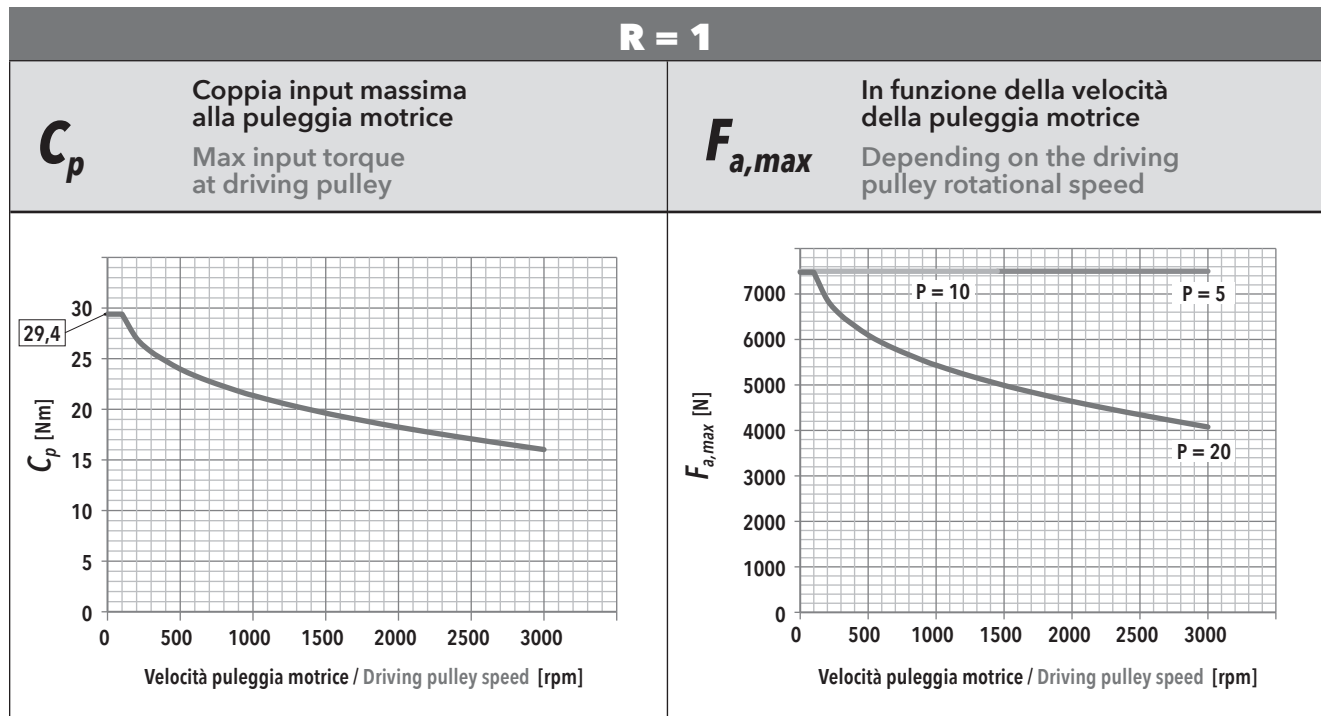

F_r Forza radiale su asse puleggia motrice in funzione di C_{in}
Radial force on driving pulley as a function of C_{in}

f_t Frequenza di vibrazione della cinghia per il tensionamento (al montaggio)
Vibration frequency of the belt for its tensioning (during assembly)

IE 63 - PASSO / PITCH 5					IE 63 - PASSO / PITCH 10					IE 63 - PASSO / PITCH 20							
F_a [N]		V_{out} [mm/s]				F_a [N]		V_{out} [mm/s]				F_a [N]		V_{out} [mm/s]			
		25	100	175	250			50	200	350	500			100	400	700	1000
7500	F_r [N]	264	267	272	281	7500	F_r [N]	528	531	537	545	7500	F_r [N]				
	f_t [Hz]	196	197	199	202		f_t [Hz]	277	278	279	282		f_t [Hz]				
6750	F_r [N]	238	240	246	255	6750	F_r [N]	475	478	484	492	6750	F_r [N]	951			
	f_t [Hz]	186	187	189	192		f_t [Hz]	263	264	265	268		f_t [Hz]	372			
6000	F_r [N]	211	214	220	228	6000	F_r [N]	423	425	431	440	6000	F_r [N]	845	846		
	f_t [Hz]	175	176	179	182		f_t [Hz]	248	249	250	253		f_t [Hz]	350	351		
5250	F_r [N]	185	188	193	202	5250	F_r [N]	370	372	378	387	5250	F_r [N]	739	742	748	
	f_t [Hz]	164	165	168	171		f_t [Hz]	232	233	234	237		f_t [Hz]	328	328	330	
4500	F_r [N]	159	161	167	176	4500	F_r [N]	317	320	325	334	4500	F_r [N]	634	636	642	651
	f_t [Hz]	152	153	156	160		f_t [Hz]	215	216	217	220		f_t [Hz]	304	304	305	308
3750	F_r [N]	132	135	140	149	3750	F_r [N]	264	267	272	281	3750	F_r [N]	528	531	537	545
	f_t [Hz]	139	140	143	147		f_t [Hz]	196	197	199	202		f_t [Hz]	277	278	279	282
3000	F_r [N]	106	108	114	123	3000	F_r [N]	211	214	220	228	3000	F_r [N]	423	425	431	440
	f_t [Hz]	124	125	129	134		f_t [Hz]	175	176	179	182		f_t [Hz]	248	249	250	253
2250	F_r [N]	79	82	88	96	2250	F_r [N]	159	161	167	176	2250	F_r [N]	317	320	325	334
	f_t [Hz]	107	109	113	118		f_t [Hz]	152	153	156	160		f_t [Hz]	215	216	217	220
1500	F_r [N]	53	56	61	70	1500	F_r [N]	106	108	114	123	1500	F_r [N]	211	214	220	228
	f_t [Hz]	88	90	94	101		f_t [Hz]	124	125	129	134		f_t [Hz]	175	176	179	182
750	F_r [N]	27	29	35	44	750	F_r [N]	53	56	61	70	750	F_r [N]	106	108	114	123
	f_t [Hz]	62	65	71	80		f_t [Hz]	88	90	94	101		f_t [Hz]	124	125	129	134

R = 2

C_p Coppia input massima alla puleggia motrice
Max input torque at driving pulley

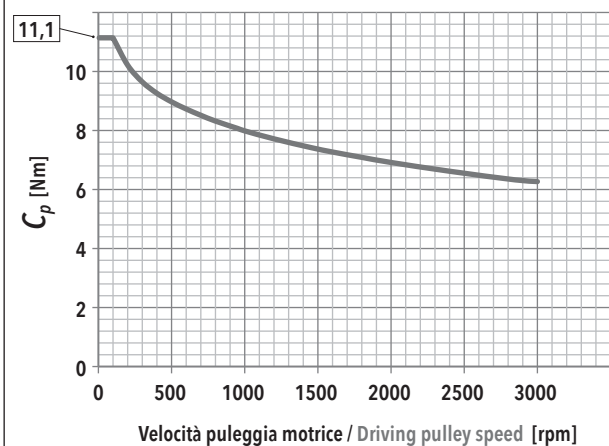

$F_{a,max}$ In funzione della velocità della puleggia motrice
Depending on the driving pulley rotational speed

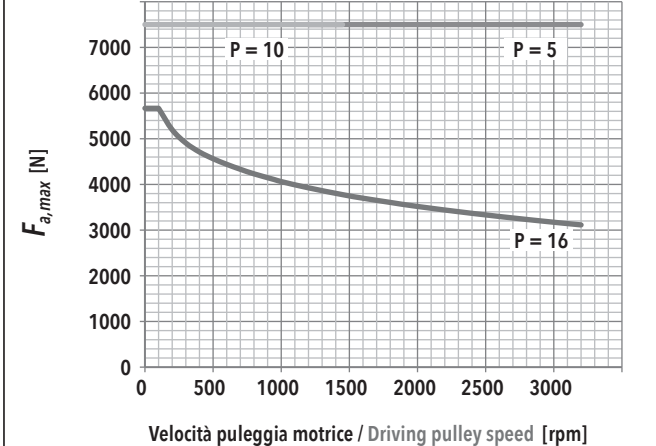

F_r Forza radiale su asse puleggia motrice in funzione di C_{in}
Radial force on driving pulley as a function of C_{in}

f_t Frequenza di vibrazione della cinghia per il tensionamento (al montaggio)
Vibration frequency of the belt for its tensioning (during assembly)

IE 63 - PASSO / PITCH 5					IE 63 - PASSO / PITCH 10					IE 63 - PASSO / PITCH 20							
F_a [N]		V_{out} [mm/s]				F_a [N]		V_{out} [mm/s]				F_a [N]		V_{out} [mm/s]			
		12,5	50	87,5	125			25	100	175	250			50	200	350	500
7500	F_r [N]	272	273	275	276	7500	F_r [N]	544	545			7500	F_r [N]				
	f_t [Hz]	205	205	207	207		f_t [Hz]	291	291				f_t [Hz]				
6750	F_r [N]	245	246	248	249	6750	F_r [N]	490	490	492		6750	F_r [N]				
	f_t [Hz]	195	195	197	197		f_t [Hz]	276	276	276	f_t [Hz]						
6000	F_r [N]	218	219	220	222	6000	F_r [N]	435	436	438	439	6000	F_r [N]				
	f_t [Hz]	184	184	186	186		f_t [Hz]	260	261	261	261		f_t [Hz]				
5250	F_r [N]	190	192	194	195	5250	F_r [N]	381	382	384	385	5250	F_r [N]				
	f_t [Hz]	172	172	173	174		f_t [Hz]	243	243	244	244		f_t [Hz]				
4500	F_r [N]	163	164	166	167	4500	F_r [N]	326	328	330	331	4500	F_r [N]	653			
	f_t [Hz]	159	160	160	161		f_t [Hz]	225	226	227	227		f_t [Hz]	318			
3750	F_r [N]	136	137	138	140	3750	F_r [N]	272	273	274	276	3750	F_r [N]	544	545		
	f_t [Hz]	145	145	146	148		f_t [Hz]	205	205	206	207		f_t [Hz]	291	291		
3000	F_r [N]	109	110	112	113	3000	F_r [N]	218	218	219	222	3000	F_r [N]	435	436	437	439
	f_t [Hz]	130	130	132	132		f_t [Hz]	184	184	186	186		f_t [Hz]	260	260	260	261
2250	F_r [N]	82	83	84	86	2250	F_r [N]	163	164	165	167	2250	F_r [N]	326	327	328	331
	f_t [Hz]	113	114	115	115		f_t [Hz]	159	159	160	161		f_t [Hz]	225	226	227	227
1500	F_r [N]	54	56	58	59	1500	F_r [N]	109	110	112	113	1500	F_r [N]	218	219	220	222
	f_t [Hz]	92	93	95	95		f_t [Hz]	130	131	132	132		f_t [Hz]	184	185	186	186
750	F_r [N]	27	28	30	31	750	F_r [N]	54	55	58	59	750	F_r [N]	109	110	112	113
	f_t [Hz]	65	66	68	70		f_t [Hz]	92	93	94	95		f_t [Hz]	130	131	132	132

3.4.6 Caratteristiche dimensionali

3.4.6 Overall dimensions

NOTA: Dati categorie motori / riduttori / rinvii al capitolo 4.

REMARK: Motors / Planetary / Angle bevel gearbox categories data at chapter 4.

B00
MODULO BASE
BASIC MODULE

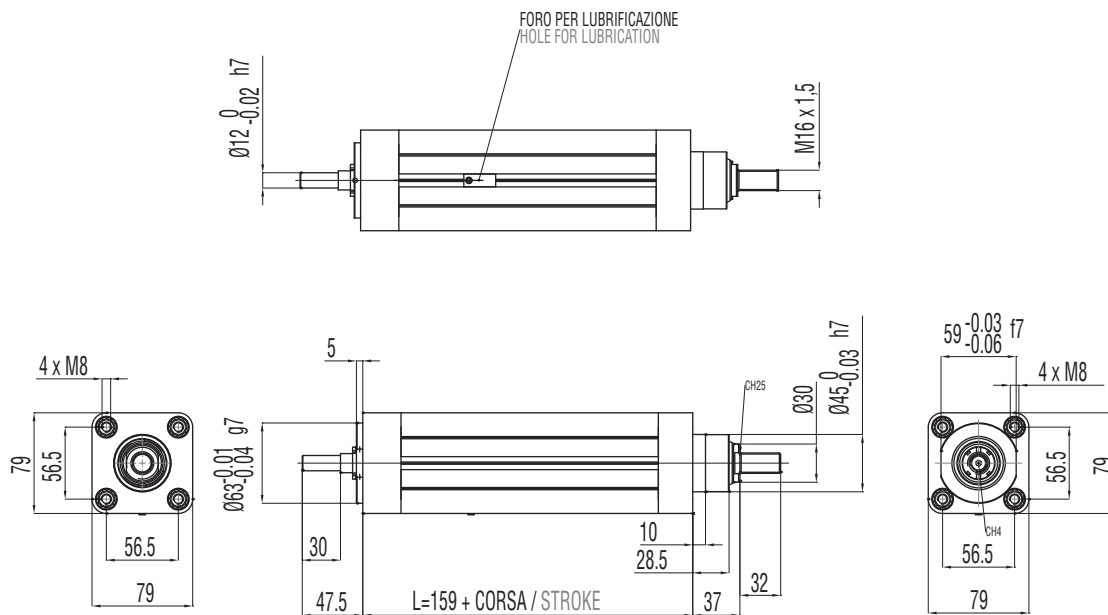
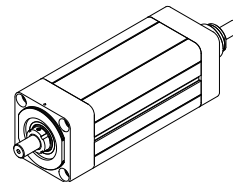

B00 + D00

MODULO BASE + TRASMISSIONE COASSIALE PER MOTORE CUSTOM
(SENZA RIDUTTORE)

**BASIC MODULE + CUSTOM IN-LINE TRANSMISSION W/O REDUCTION STAGE
FOR CUSTOM MOTORS**

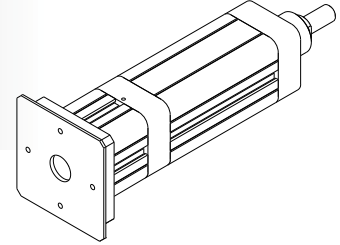

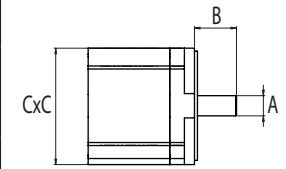
	MASSIME DIMENSIONI INTERFACCIA MAX INTERFACE DIMENSIONS			
	TAGLIA GIUNTO COUPLING SIZE	A [mm]	B [mm]	C [mm]
	60	30 max	28 min / 42 max	100 max

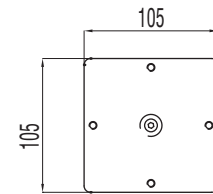
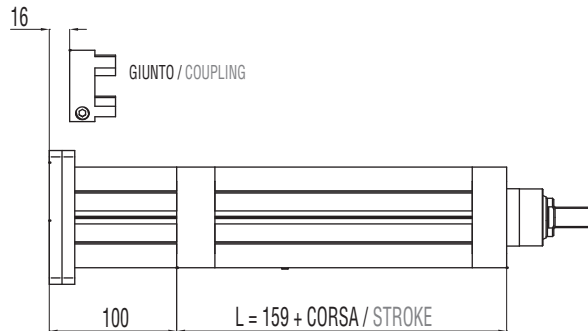

B00 + D01

MODULO BASE + TRASMISSIONE COASSIALE PER MOTORE COMPATIBILE
(SENZA RIDUTTORE)

**BASIC MODULE + IN-LINE TRANSMISSION W/O REDUCTION STAGE FOR
COMPATIBLE MOTORS**

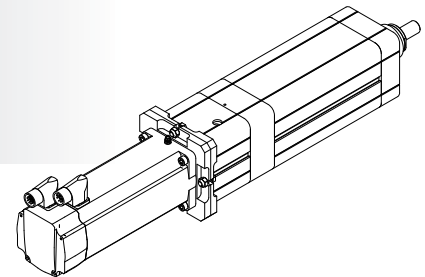

- | |
|-----------------|
| MOTORE
MOTOR |
| MDA |
| MDB |
| MDC |
| MEA |

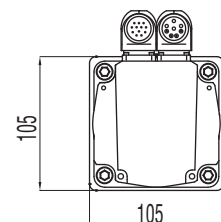
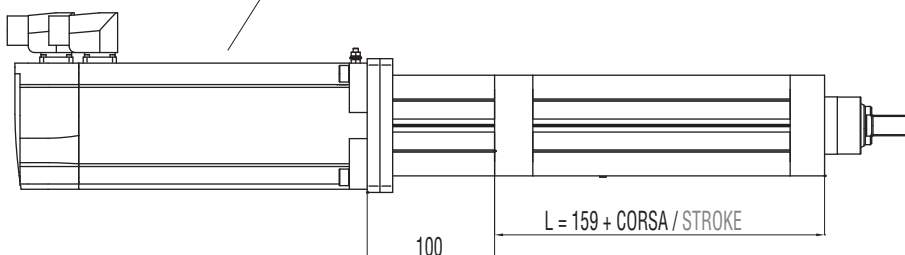

B00 + D02

MODULO BASE + RIDUTTORE EPICICLOIDALE COASSIALE COMPATIBILE

BASIC MODULE + IN-LINE COMPATIBLE PLANETARY GEARBOX REDUCTION STAGE

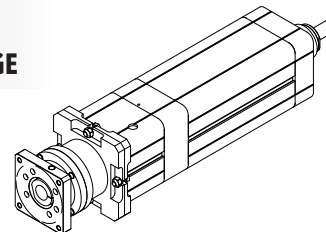

RIDUTTORE PLANETARY GEARBOX
GBA
GBB
GCB

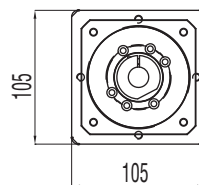
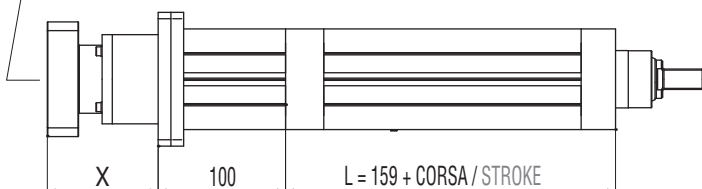

B00 + A01

MODULO BASE + RINVIO ANGOLARE COMPATIBILE

BASIC MODULE + COMPATIBLE ANGLE BEVEL GEARBOX STAGE

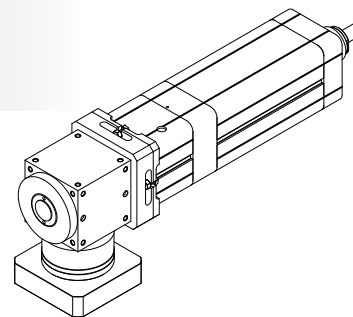

RINVIO BEVEL GEARBOX
ABA

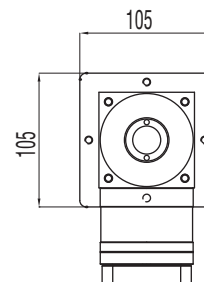
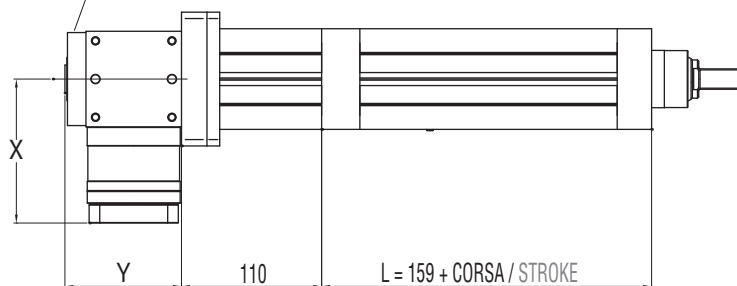

B00 + R00

MODULO BASE + TRASMISSIONE A CINGHIA IN PARALLELO PER MOTORE CUSTOM

BASIC MODULE + PARALLEL CUSTOM BELT GEARBOX STAGE FOR CUSTOM MOTORS

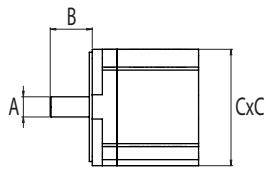
	DIMENSIONI LIMITI INTERFACCIA MAX INTERFACE DIMENSIONS		
	A [mm]	B [mm]	C [mm]
R=1:1	16 max	28 min / 42 max	100 max
R=1:2	14 max	30 min / 40 max	100 max

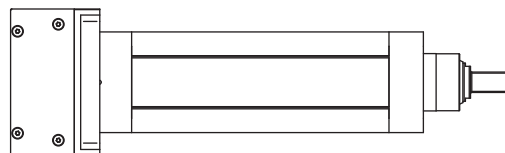
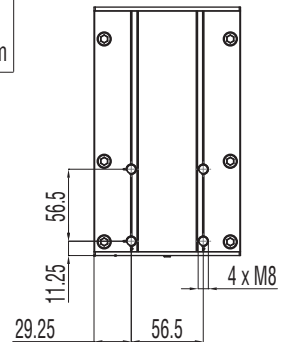
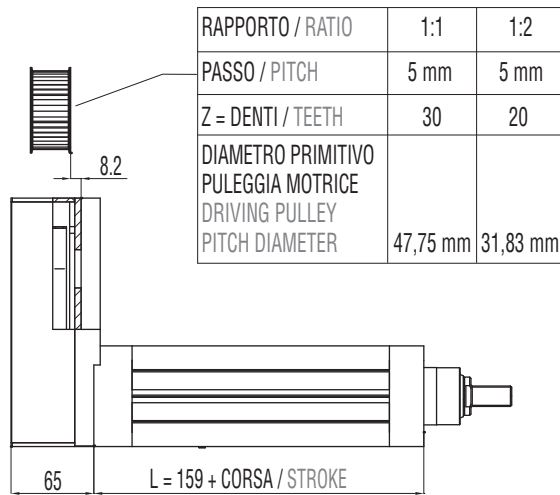
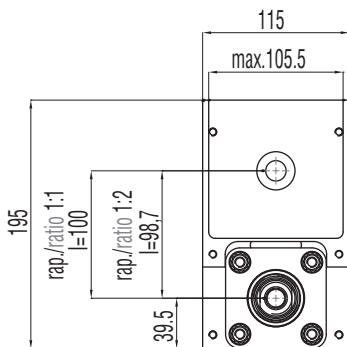
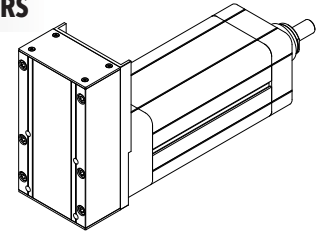

B00 + R01

MODULO BASE + TRASMISSIONE A CINGHIA IN PARALLELO PER MOTORE COMPATIBILE

BASIC MODULE + PARALLEL BELT GEARBOX STAGE FOR COMPATIBLE MOTORS

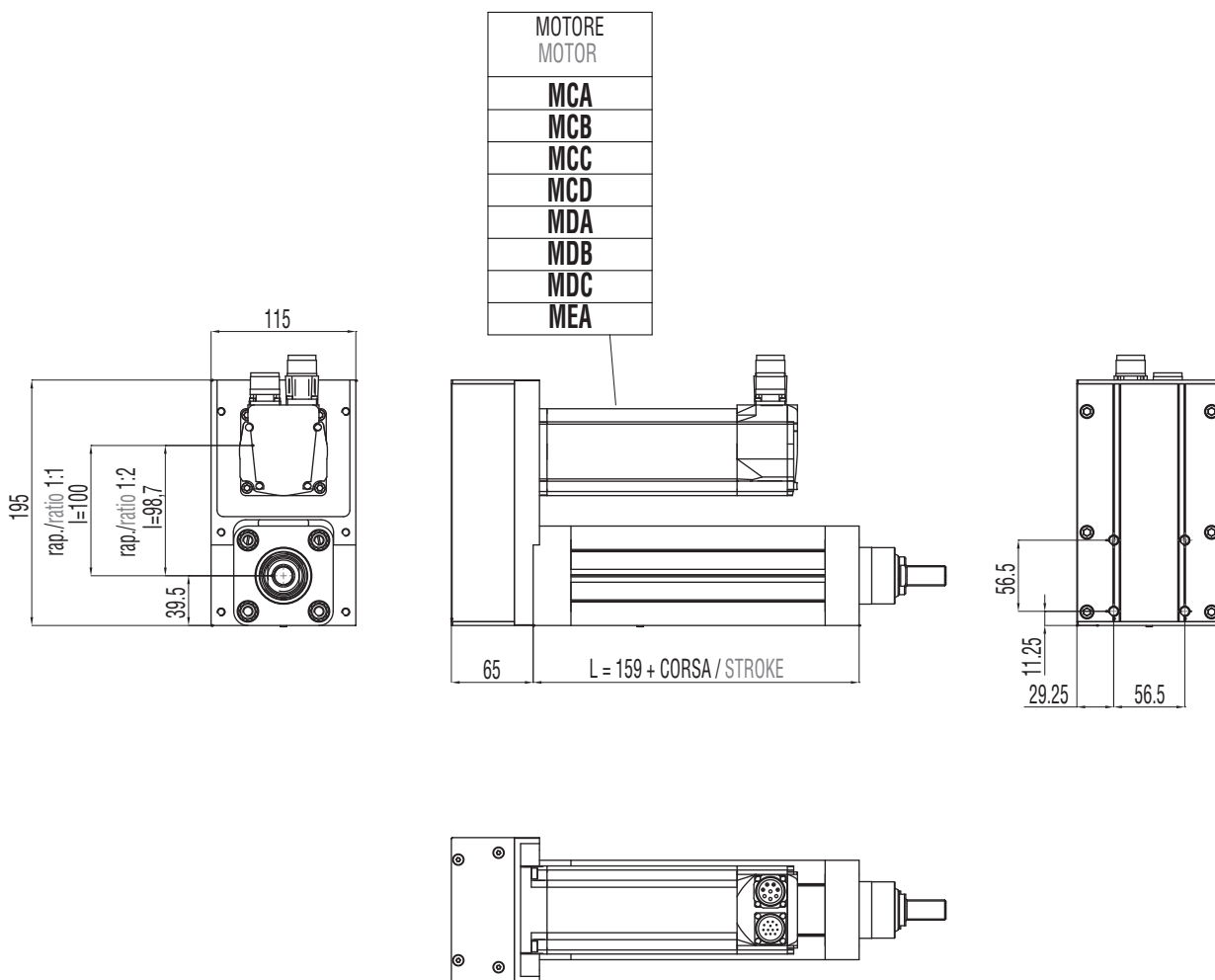
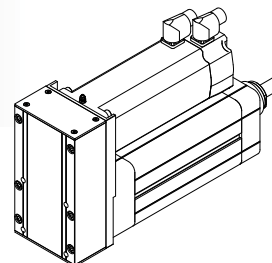

B00 + R02

MODULO BASE + TRASMISSIONE A CINGHIA IN PARALLELO +
RIDUTTORE EPICICLOIDALE COMPATIBILE

**BASIC MODULE + PARALLEL BELT GEARBOX STAGE +
IN-LINE COMPATIBLE PLANETARY GEARBOX REDUCTION STAGE**

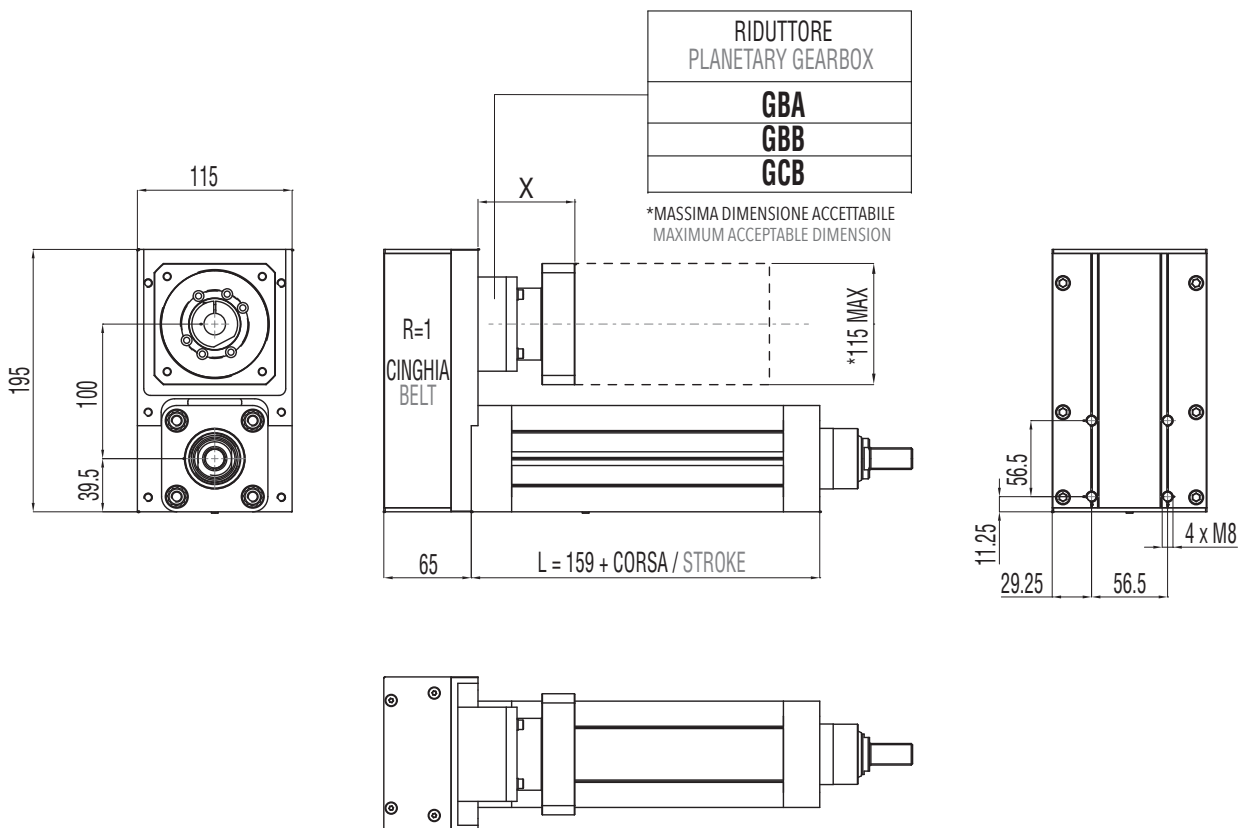
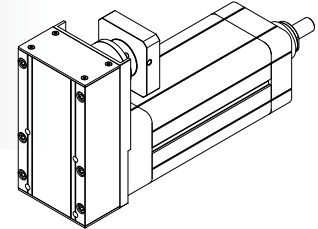

3.4.7 Accessori disponibili

Per le tabelle e i disegni tecnici degli accessori disponibili fare riferimento al paragrafo 3.10 (da pag. 136).

3.4.7 Available accessories

For tables and drawings please refer to paragraph 3.10 (from page 136).

3.5

IE 80

3.5.1 Caratteristiche tecniche

3.5.1 Technical features

ISOMOVE IE 80		5	10	25
P	PASSO VITE SCREW LEAD [mm]	5	10	25
D	DIAMETRO VITE SCREW DIAMETER [mm]	25	25	25
F_d	CARICO MASSIMO DINAMICO APPLICABILE MAX ADMISSIBLE DYNAMIC LOAD [N]	12000*	12000*	12000*
C_{in,max}	PER AVERE $F_a = F_d$ TO GET [Nm]	10,6	21,3	53
	"CASO 1" / "CASE 1": B00 + D00/D01 [Nm]	10,6	21,3	53
	"CASO 2" / "CASE 2": B00 + D02/A01 [Nm]	$\left[\frac{11,7}{R} \right] + C_s$	$\left[\frac{23,6}{R} \right] + C_s$	$\left[\frac{58,8}{R} \right] + C_s$
		R = rapporto di riduzione del riduttore / rinvio angolare R = planetary / angle bevel gearbox reduction ratio		
C_{m,max}	"CASO 3" / "CASE 3": B00 + R00/R01 [Nm]	$\frac{11,7}{R}$	$\frac{23,6}{R}$	$\frac{58,8}{R}$
		R = rapporto di riduzione della trasmissione a cinghia (disponibile R=1 oppure R=2) R = belt gearbox reduction ratio (available R=1 or R=2)		
	"CASO 4" / "CASE 4": B00 + R02 [Nm]	$\frac{13}{R}$	$\frac{26,2}{R}$	$\frac{65,3}{R}$
		R = rapporto di riduzione del riduttore epicicloidale R = planetary gearbox reduction ratio		
F_{st}	CARICO MASSIMO STATICO APPLICABILE MAX ADMISSIBLE STATIC LOAD [N]	12000	12000	12000
V_{out,max}	VELOCITÀ DI TRASLAZIONE MASSIMA IN USCITA / ROTAZIONE MASSIMA VITE RDS [mm/sec]	250/3000	500/3000	1250/3000
N_{in,max}	MAX OUTPUT SPEED / MAX BALLSCREW ROTATING INPUT SPEED [rpm]			
a_{max}	ACCELERAZIONE MASSIMA IN USCITA MAX OUTPUT ACCELERATION [m/sec ²]	1	2	4
S_{max}	CORSA MASSIMA STANDARD MAX STANDARD STROKE [mm]	1000**	1000**	1000**
	PESO MODULO BASE CORSA 0 mm / PESO OGNI 100 mm DI CORSA BASIC MODULE WEIGHT FOR 0 mm STROKE / WEIGHT FOR ADDITIONAL 100 mm STROKE [Kg]	3,4 / 1,2	3,4 / 1,2	3,4 / 1,2
G_{s,max}	GIOCO ASSIALE MASSIMO PER CHIOCCIOLA STANDARD MAX AXIAL BACKLASH FOR STANDARD BALLSCREW ASSEMBLY [mm]	0,06	0,06	0,06
G_z	GIOCO "0" DELLA CHIOCCIOLA "0" BACKLASH BALLSCREW ASSEMBLY	DISPONIBILE / AVAILABLE		
L_{10,Km}	DURATA LIFETIME [Km]	VEDI TABELLA / SEE TABLE pg. 76		

* Per le versioni R00/R01 controllare con i grafici delle pagine 78/79. / For R00/R01 types please check graph at pages 78/79.

** Per corse superiori, contattare il nostro servizio tecnico. / For longer strokes please contact our technical dept.

ISOMOVE IE 80		5	10	25
VERSIONI DISPONIBILI AVAILABLE TYPES		D00 / D01 / D02 / R00 / R01 / R02 / A01		
$F_{a,p}$	POSSIBILE CON IL RIDUTTORE EPICICLOIDALE INDICATO POSSIBLE VALUE WITH THE INDICATED PLANETARY GEARBOX	[N]	AE070/12000 PGII-080/12000	AE070/12000 PGII-080/12000 AE070/7000 *** PGII-080/12000
	POSSIBILE CON IL RINVIO ANGOLARE INDICATO POSSIBLE VALUE WITH THE INDICATED ANGLE BEVEL GEARBOX	[N]	ATB090/12000	ATB090/12000 ATB090/5800 ***
ACCESSORI DISPONIBILI AVAILABLE ACCESSORIES		VEDI PARAGRAFO / SEE PARAGRAPH 3.10 (pg. 136)		

*** È il valore massimo ottenibile con il rapporto di riduzione disponibile avente il minore valore di coppia erogabile.
It is the max obtainable value with the available on tables reduction ratio which has the lowest value of nominal output torque.

RIDUTTORI-RINVII "STANDARD SETEC GROUP DISPONIBILI"
"STANDARD SETEC GROUP AVAILABLE" PLANETARY-ANGLE BEVEL GEARBOXES

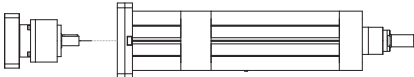
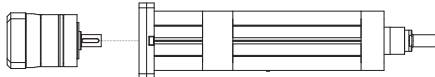
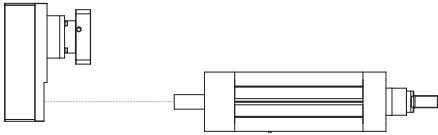
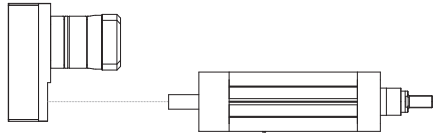
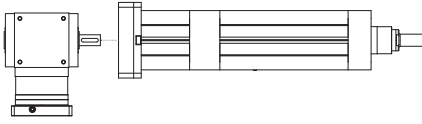
<p>TRASMISSIONE COASSIALE CON RIDUTTORE</p> <p>IN-LINE PLANETARY GEARBOX STAGE</p>	 <p>AE070</p> <p>MODULO BASE BASIC MODULE</p>	 <p>PGII-080</p> <p>MODULO BASE BASIC MODULE</p>
<p>TRASMISSIONE PARALLELA CON RIDUTTORE</p> <p>PARALLEL BELT GEARBOX STAGE + IN-LINE PLANETARY GEARBOX REDUCTION STAGE</p>	 <p>AE070</p> <p>MODULO BASE BASIC MODULE</p>	 <p>PGII-080</p> <p>MODULO BASE BASIC MODULE</p>
<p>TRASMISSIONE ANGOLARE CON RINVIO</p> <p>ANGLE BEVEL GEARBOX STAGE</p>	 <p>ATB090</p> <p>MODULO BASE BASIC MODULE</p>	

3.5.2 Calcolo durata

3.5.2 Lifetime calculation

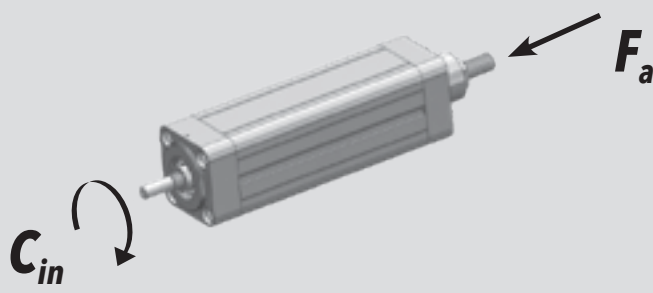

IE 80 P = 5 mm	$L_{10,Km} = \left[\frac{13700}{F_{eq}} \right]^3 \cdot 5$	$L_{10,Km} = [Km]$ $F_{eq} = [N]$
IE 80 P = 10 mm	$L_{10,Km} = \left[\frac{25200}{F_{eq}} \right]^3 \cdot 10$	$L_{10,Km} = [Km]$ $F_{eq} = [N]$
IE 80 P = 25 mm	$L_{10,Km} = \left[\frac{16700}{F_{eq}} \right]^3 \cdot 25$	$L_{10,Km} = [Km]$ $F_{eq} = [N]$

3.5.3 Calcolo coppia in ingresso
al modulo base3.5.3 Torque calculation at basic
module input shaft

		
IE 80 P = 5 mm	$C_{in} = \left[\frac{F_a \cdot 5}{5652} \right]$	$C_{in} = [Nm]$ $F_a = [N]$
IE 80 P = 10 mm	$C_{in} = \left[\frac{F_a \cdot 10}{5652} \right]$	$C_{in} = [Nm]$ $F_a = [N]$
IE 80 P = 25 mm	$C_{in} = \left[\frac{F_a \cdot 25}{5652} \right]$	$C_{in} = [Nm]$ $F_a = [N]$

3.5.4 Calcolo coppia motore

3.5.4 Motor torque calculation

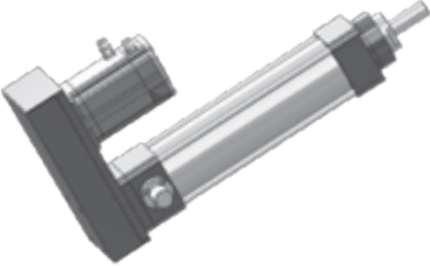
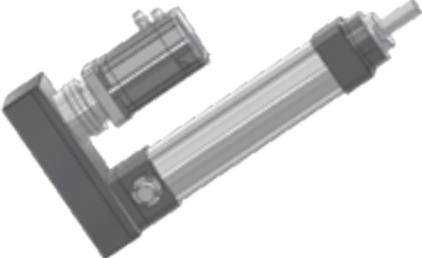
<p>CASO / CASE 1</p>	<p>ISOMOVE B00 + D00 / D01</p>  $C_m = C_{in} \quad [Nm]$
<p>CASO / CASE 2</p>	<p>ISOMOVE B00 + D02 / A01</p>  $C_m = \left[\frac{C_{in}}{R \cdot \eta} \right] + C_s \quad [Nm]$ <p><i>R</i> = rapporto di riduzione riduttore / rinvio planetary / angle bevel gearbox reduction ratio <i>η</i> = rendimento meccanico / mechanical efficiency = 0,90</p>
<p>CASO / CASE 3</p>	<p>ISOMOVE B00 + R00 / R01</p>  $C_m = \left[\frac{C_{in}}{R \cdot \eta} \right] \quad [Nm]$ <p><i>R</i> = rapporto di riduzione trasmissione a cinghia, disponibile R=1 o R=2 belt gearbox reduction ratio, available R=1 or R=2 <i>η</i> = rendimento meccanico / mechanical efficiency = 0,90</p>
<p>CASO / CASE 4</p>	<p>ISOMOVE B00 + R02</p>  $C_m = \left[\frac{C_{in}}{R \cdot \eta} \right] + C_s \quad [Nm]$ <p><i>R</i> = rapporto di riduzione riduttore epicicloidale planetary gearbox reduction ratio <i>η</i> = rendimento meccanico / mechanical efficiency = 0,81</p>

3.5.5 Potenza in ingresso alla trasmissione a cinghia (versione R)

3.5.5 Mechanical input power at belt gear stage (R type)

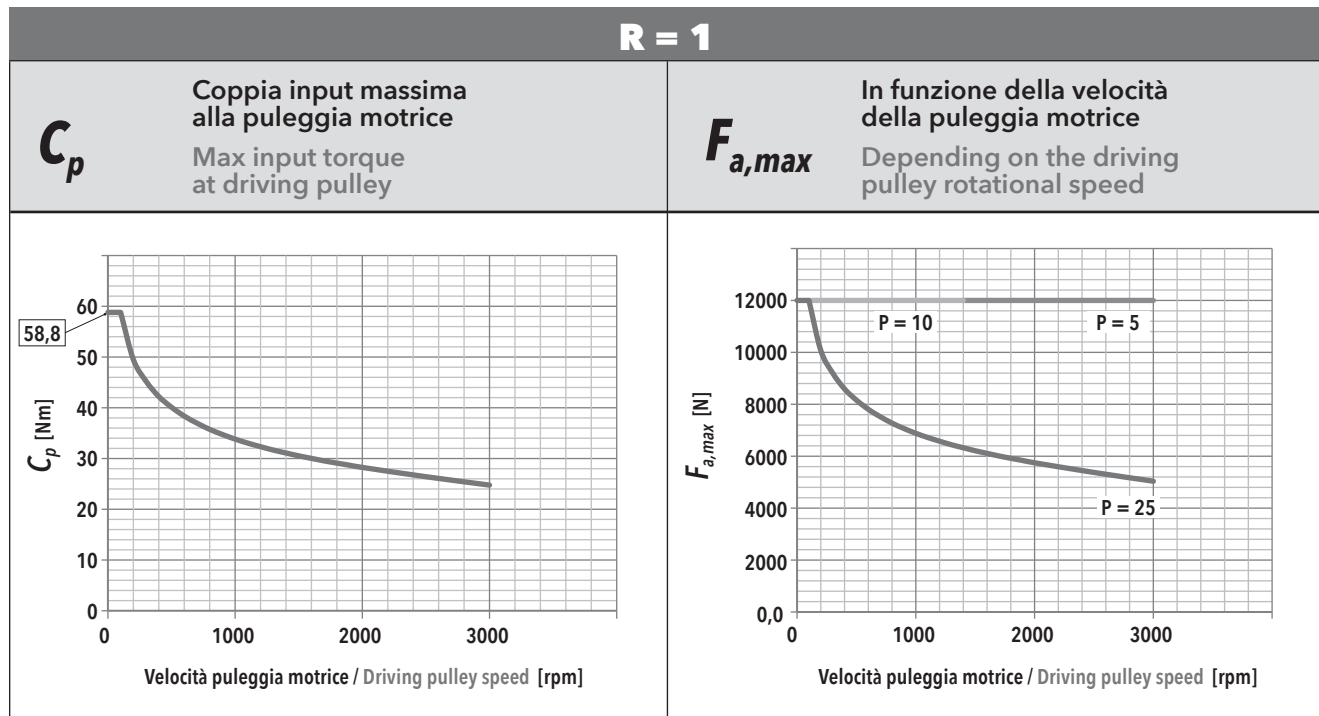

F_r Forza radiale su asse puleggia motrice in funzione di C_{in}
Radial force on driving pulley as a function of C_{in}

f_t Frequenza di vibrazione della cinghia per il tensionamento (al montaggio)
Vibration frequency of the belt for its tensioning (during assembly)

IE 80 - PASSO / PITCH 5					IE 80 - PASSO / PITCH 10					IE 80 - PASSO / PITCH 25							
F_a [N]		V_{out} [mm/s]				F_a [N]		V_{out} [mm/s]				F_a [N]		V_{out} [mm/s]			
		25	100	175	250			50	200	350	500			125	500	870	1250
12000	F_r [N]	353	360	376	402	12000	F_r [N]	705	712	728	754	12000	F_r [N]				
	f_t [Hz]	156	157	160	174		f_t [Hz]	223	225	226	230		f_t [Hz]				
10800	F_r [N]	317	325	341	366	10800	F_r [N]	634	642	658	683	10800	F_r [N]				
	f_t [Hz]	148	150	152	156		f_t [Hz]	212	215	218	220		f_t [Hz]				
9600	F_r [N]	282	290	306	331	9600	F_r [N]	564	571	588	613	9600	F_r [N]	1409			
	f_t [Hz]	138	141	145	147		f_t [Hz]	199	200	202	205		f_t [Hz]	315			
8400	F_r [N]	247	254	271	296	8400	F_r [N]	493	495	517	542	8400	F_r [N]	1233			
	f_t [Hz]	132	135	138	140		f_t [Hz]	190	191	193	195		f_t [Hz]	295			
7200	F_r [N]	212	219	236	261	7200	F_r [N]	423	430	447	472	7200	F_r [N]	1057	1064		
	f_t [Hz]	128	130	133	135		f_t [Hz]	174	175	178	180		f_t [Hz]	273	275		
6000	F_r [N]	177	184	200	226	6000	F_r [N]	353	360	376	402	6000	F_r [N]	881	888		
	f_t [Hz]	118	120	122	125		f_t [Hz]	164	165	168	170		f_t [Hz]	248	250		
4800	F_r [N]	141	149	165	190	4800	F_r [N]	282	290	306	331	4800	F_r [N]	705	712	728	754
	f_t [Hz]	105	108	108	110		f_t [Hz]	144	146	148	150		f_t [Hz]	220	222	225	226
3600	F_r [N]	106	114	130	155	3600	F_r [N]	212	219	236	261	3600	F_r [N]	529	536	552	578
	f_t [Hz]	95	96	98	100		f_t [Hz]	130	132	133	135		f_t [Hz]	194	195	196	198
2400	F_r [N]	71	78	95	120	2400	F_r [N]	141	149	165	190	2400	F_r [N]	353	360	376	402
	f_t [Hz]	80	82	84	85		f_t [Hz]	109	110	113	115		f_t [Hz]	160	161	163	165
1200	F_r [N]	36	43	59	85	1200	F_r [N]	71	78	95	120	1200	F_r [N]	177	184	200	226
	f_t [Hz]	64	65	68	70		f_t [Hz]	84	85	88	90		f_t [Hz]	118	120	122	125

R = 2

C_p Coppia input massima alla puleggia motrice
Max input torque at driving pulley

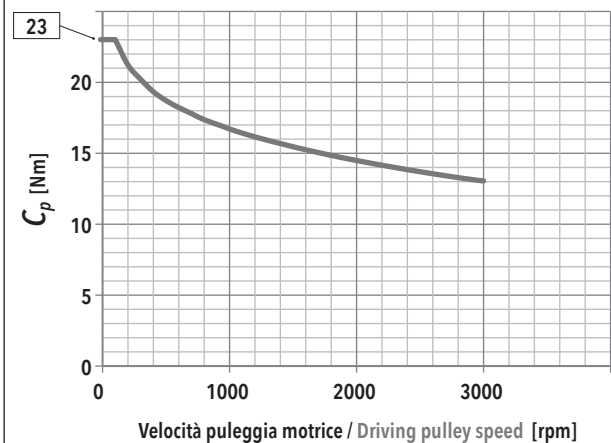

$F_{a,max}$ In funzione della velocità della puleggia motrice
Depending on the driving pulley rotational speed

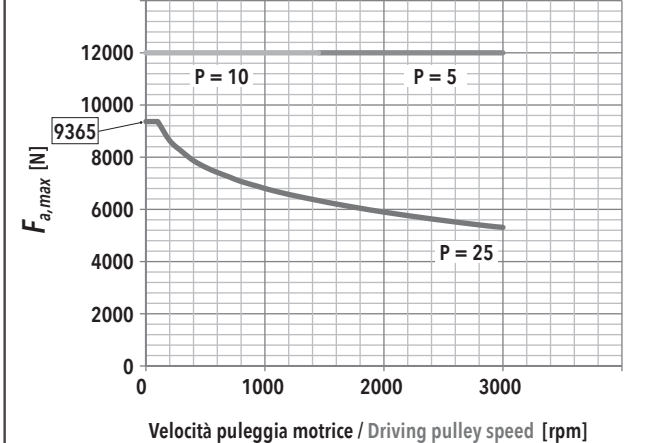

F_r Forza radiale su asse puleggia motrice in funzione di C_{in}
Radial force on driving pulley as a function of C_{in}

f_t Frequenza di vibrazione della cinghia per il tensionamento (al montaggio)
Vibration frequency of the belt for its tensioning (during assembly)

IE 80 - PASSO / PITCH 5					IE 80 - PASSO / PITCH 10					IE 80 - PASSO / PITCH 25							
F_a [N]		V_{out} [mm/s]				F_a [N]		V_{out} [mm/s]				F_a [N]		V_{out} [mm/s]			
		12,5	50	87,5	125			25	100	175	250			62,5	250	438	625
12000	F_r [N]	363	365	367	369	12000	F_r [N]	726	728	730	732	12000	F_r [N]				
	f_t [Hz]	193	194	195	195		f_t [Hz]	274	274	274	275		f_t [Hz]				
10800	F_r [N]	327	329	331	333	10800	F_r [N]	653	656	658	659	10800	F_r [N]				
	f_t [Hz]	184	184	185	185		f_t [Hz]	260	260	261	261		f_t [Hz]				
9600	F_r [N]	290	292	295	296	9600	F_r [N]	581	582	585	587	9600	F_r [N]				
	f_t [Hz]	173	173	175	175		f_t [Hz]	245	245	246	246		f_t [Hz]				
8400	F_r [N]	254	256	258	260	8400	F_r [N]	508	510	512	514	8400	F_r [N]	1270			
	f_t [Hz]	162	162	164	164		f_t [Hz]	229	229	230	230		f_t [Hz]	362			
7200	F_r [N]	218	220	222	224	7200	F_r [N]	436	438	440	442	7200	F_r [N]	1089	1090		
	f_t [Hz]	150	151	152	152		f_t [Hz]	212	212	213	213		f_t [Hz]	335	335		
6000	F_r [N]	182	185	197	188	6000	F_r [N]	363	365	367	369	6000	F_r [N]	907	908	910	
	f_t [Hz]	137	137	138	139		f_t [Hz]	193	194	195	195		f_t [Hz]	306	306	306	
4800	F_r [N]	145	147	150	151	4800	F_r [N]	290	292	294	296	4800	F_r [N]	726	728	730	732
	f_t [Hz]	122	123	124	125		f_t [Hz]	173	173	174	175		f_t [Hz]	274	274	275	275
3600	F_r [N]	109	111	112	115	3600	F_r [N]	218	220	221	224	3600	F_r [N]	544	546	548	551
	f_t [Hz]	106	107	108	109		f_t [Hz]	150	150	152	152		f_t [Hz]	237	237	238	238
2400	F_r [N]	73	75	78	79	2400	F_r [N]	145	147	150	151	2400	F_r [N]	363	365	368	369
	f_t [Hz]	87	88	89	90		f_t [Hz]	122	123	124	125		f_t [Hz]	193	193	195	195
1200	F_r [N]	36	37	39	42	1200	F_r [N]	73	73	79	79	1200	F_r [N]	182	184	186	188
	f_t [Hz]	61	63	65	66		f_t [Hz]	87	88	89	90		f_t [Hz]	137	137	139	139

3.5.6 Caratteristiche dimensionali

3.5.6 Overall dimensions

NOTA: Dati categorie motori / riduttori / rinvii al capitolo 4.

REMARK: Motors / Planetary / Angle bevel gearbox categories data at chapter 4.

B00
MODULO BASE
BASIC MODULE

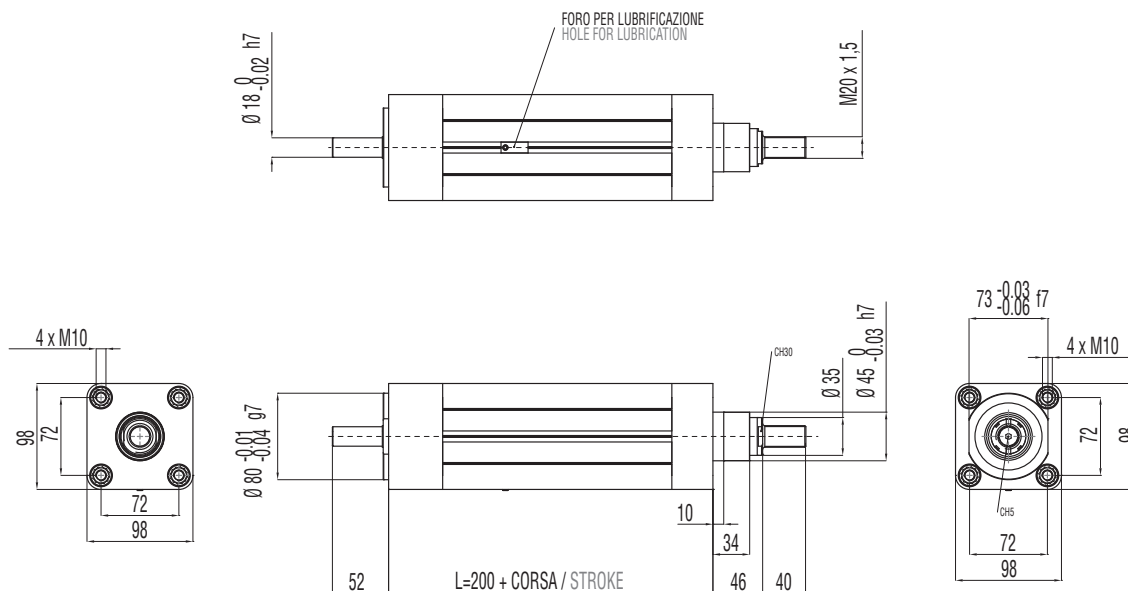
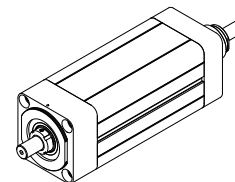

B00 + D00

MODULO BASE + TRASMISSIONE COASSIALE PER MOTORE CUSTOM
(SENZA RIDUTTORE)

**BASIC MODULE + CUSTOM IN-LINE TRANSMISSION W/O REDUCTION STAGE
FOR CUSTOM MOTORS**

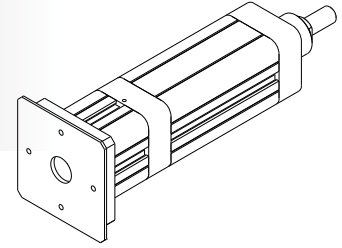

	MASSIME DIMENSIONI INTERFACCIA MAX INTERFACE DIMENSIONS			
	TAGLIA GIUNTO COUPLING SIZE	A	B	C
	[mm]	[mm]	[mm]	
60	26 max	42 min / 50 max	110 max	

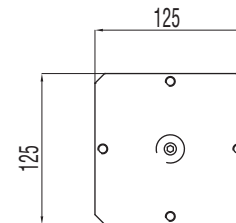
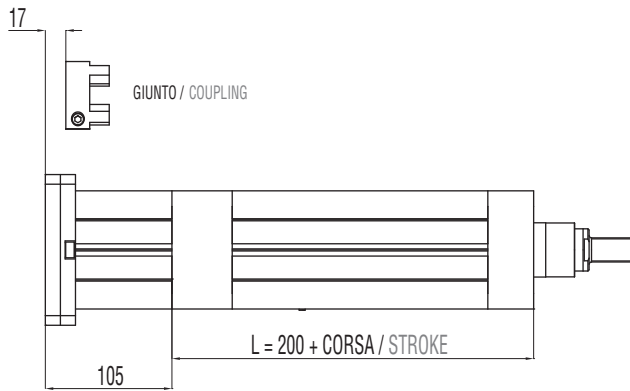

B00 + D01

MODULO BASE + TRASMISSIONE COASSIALE PER MOTORE COMPATIBILE
(SENZA RIDUTTORE)

**BASIC MODULE + IN-LINE TRANSMISSION W/O REDUCTION STAGE FOR
COMPATIBLE MOTORS**

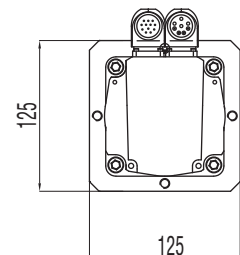
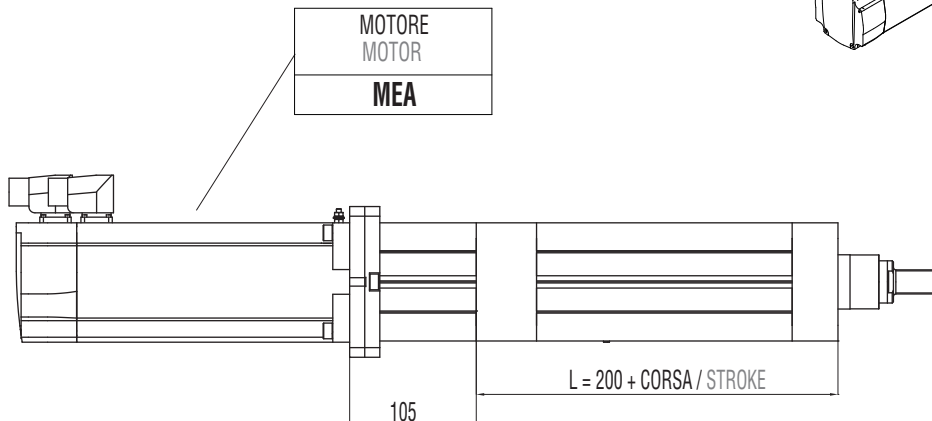
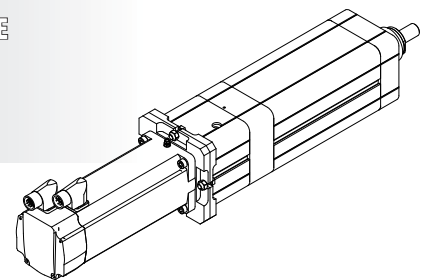

B00 + D02

MODULO BASE + RIDUTTORE EPICICLOIDALE COASSIALE COMPATIBILE

BASIC MODULE + IN-LINE COMPATIBLE PLANETARY GEARBOX REDUCTION STAGE

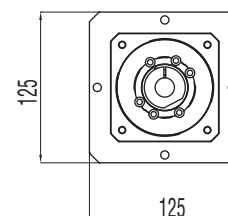
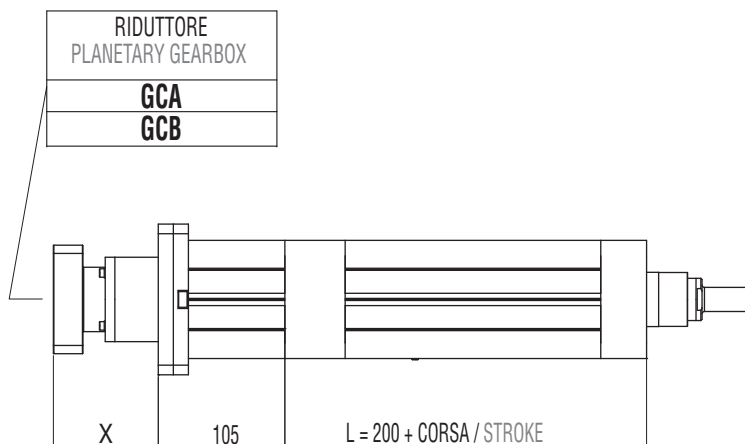
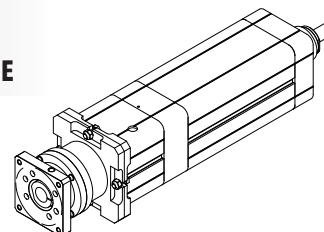

B00 + A01

MODULO BASE + RINVIO ANGOLARE COMPATIBILE

BASIC MODULE + COMPATIBLE ANGLE BEVEL GEARBOX STAGE

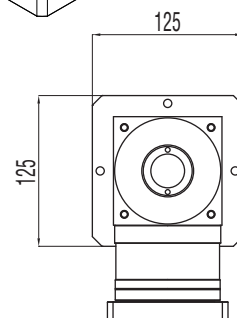
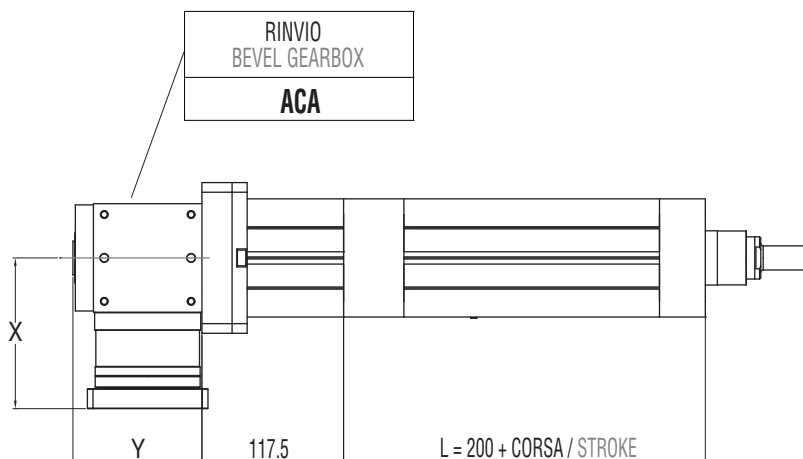
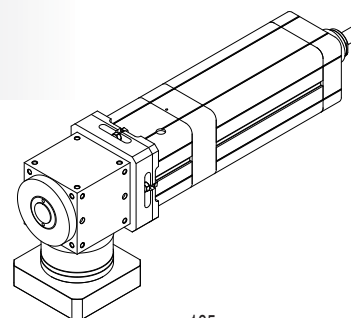

B00 + R00

MODULO BASE + TRASMISSIONE A CINGHIA IN PARALLELO PER MOTORE CUSTOM

BASIC MODULE + PARALLEL CUSTOM BELT GEARBOX STAGE FOR CUSTOM MOTORS

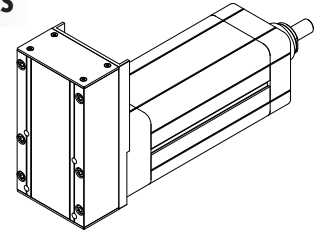

	DIMENSIONI LIMITI INTERFACCIA MAX INTERFACE DIMENSIONS		
	A [mm]	B [mm]	C [mm]
R=1:1	24 max	42 min / 58 max	110 max
R=1:2	19 max	36 min / 50 max	110 max

RAPPORTO / RATIO	1:1	1:2
PASSO / PITCH	8 mm	5 mm
Z = DENTI / TEETH	30	24
DIAMETRO PRIMITIVO PULEGGIA MOTRICE DRIVING PULLEY PITCH DIAMETER	76,39 mm	38,2 mm

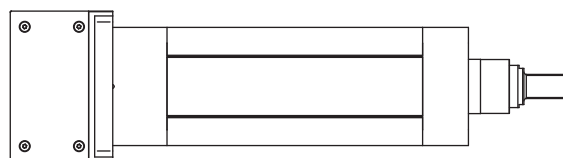
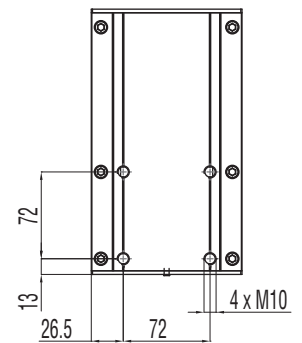
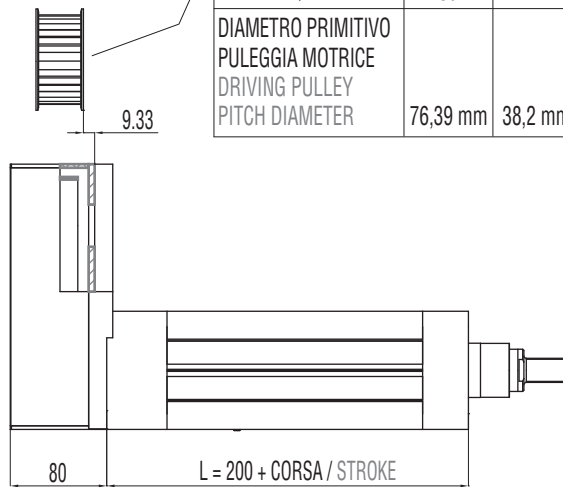
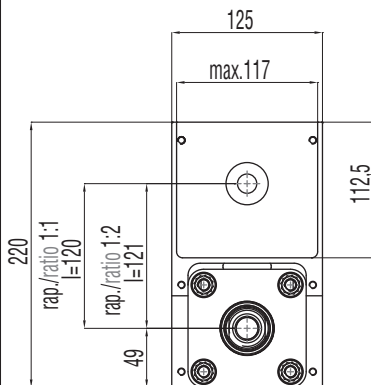

B00 + R01

MODULO BASE + TRASMISSIONE A CINGHIA IN PARALLELO PER MOTORE COMPATIBILE

BASIC MODULE + PARALLEL BELT GEARBOX STAGE FOR COMPATIBLE MOTORS

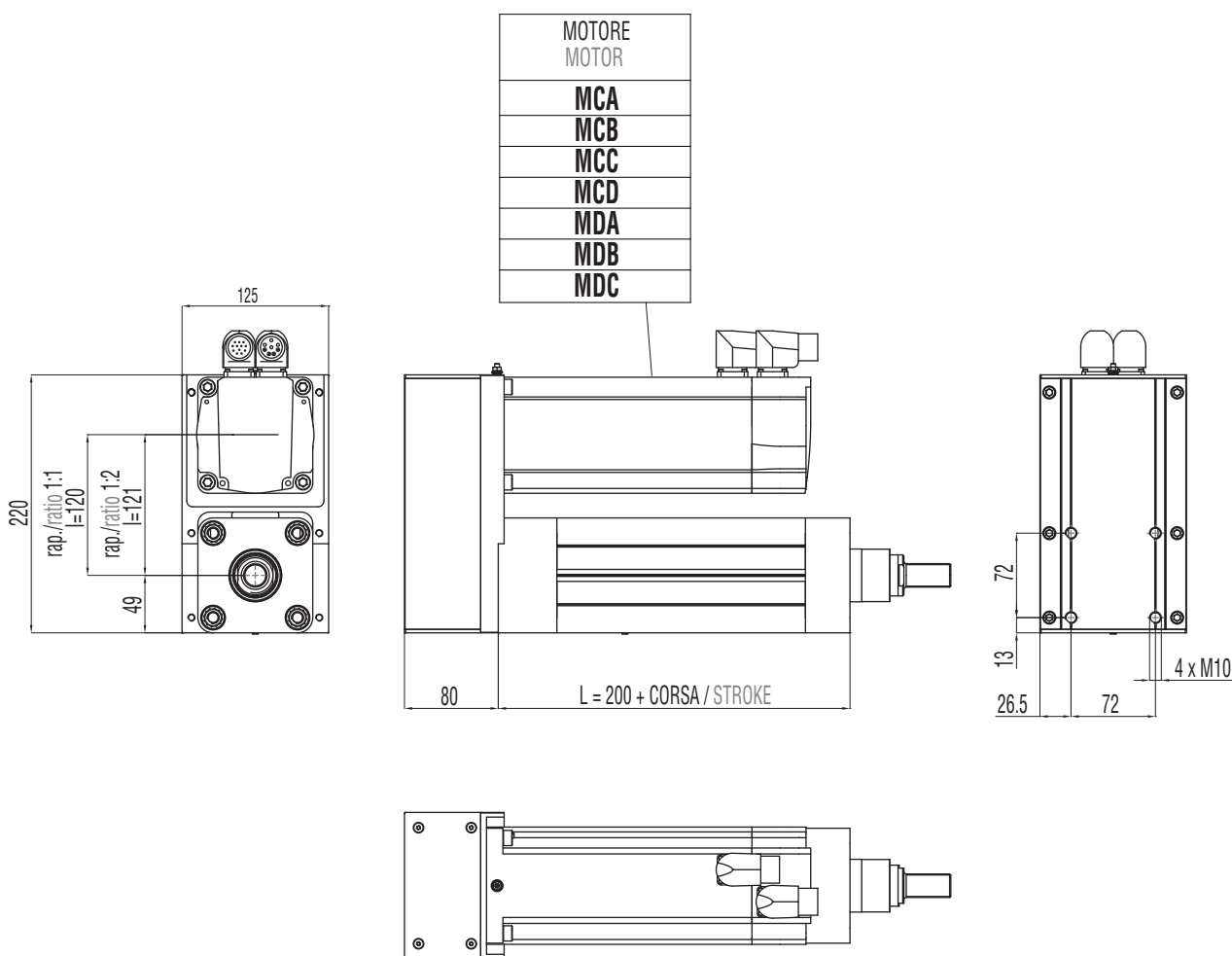
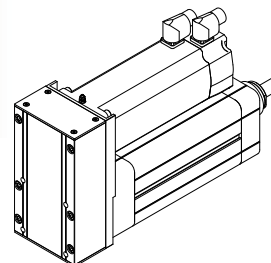

B00 + R02

MODULO BASE + TRASMISSIONE A CINGHIA IN PARALLELO +
RIDUTTORE EPICICLOIDALE COMPATIBILE

**BASIC MODULE + PARALLEL BELT GEARBOX STAGE +
IN-LINE COMPATIBLE PLANETARY GEARBOX REDUCTION STAGE**

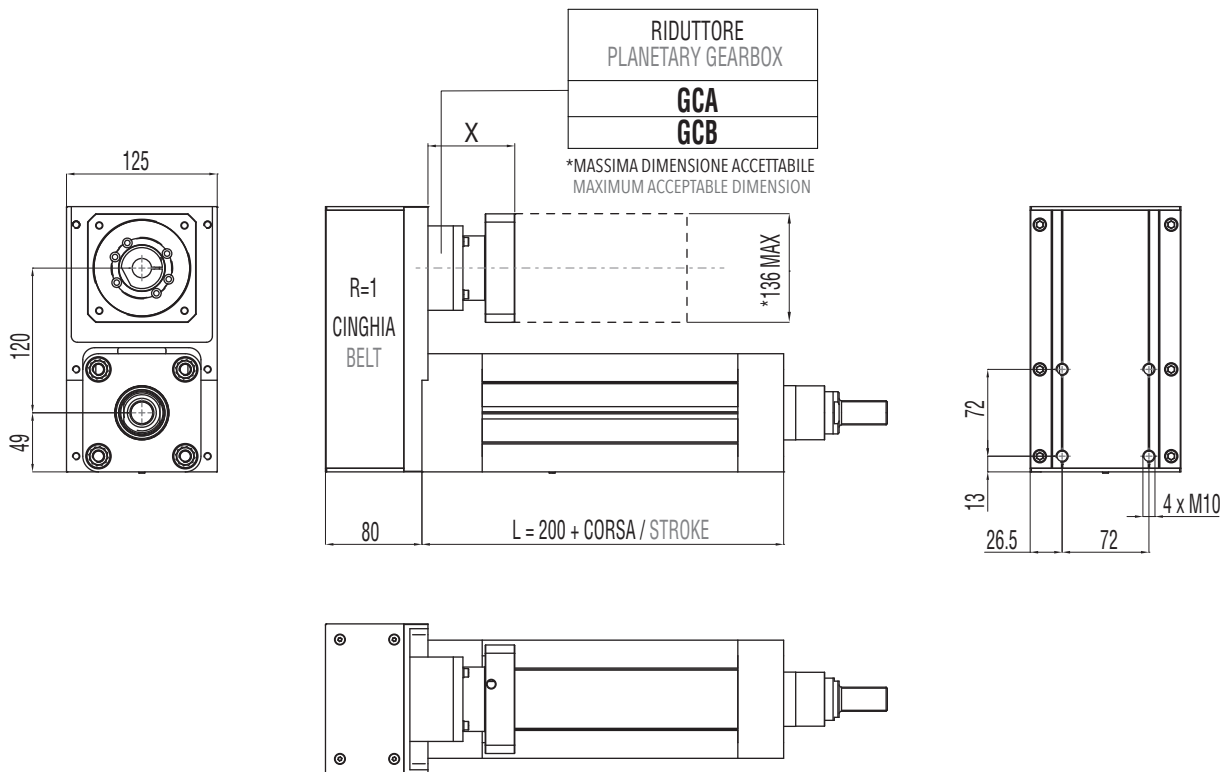
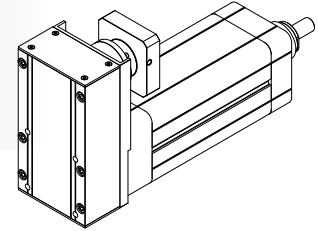

3.5.7 Accessori disponibili

Per le tabelle e i disegni tecnici degli accessori disponibili fare riferimento al paragrafo 3.10 (da pag. 136).

3.5.7 Available accessories

For tables and drawings please refer to paragraph 3.10 (from page 136).

3.6

IE 80 HL

3.6.1 Caratteristiche tecniche

3.6.1 Technical features

ISOMOVE IE 80 HL		5	10	32
P	PASSO VITE SCREW LEAD [mm]	5	10	32
D	DIAMETRO VITE SCREW DIAMETER [mm]	32	32	32
F_d	CARICO MASSIMO DINAMICO APPLICABILE MAX ADMISSIBLE DYNAMIC LOAD [N]	21000*	25000*	18000*
C_{in,max}	PER AVERE $F_a = F_d$ TO GET [Nm]	18,5	44,3	101,9
	"CASO 1" / "CASE 1": B00 + D00/D01 [Nm]	18,5	44,3	101,9
	"CASO 2" / "CASE 2": B00 + D02/A01 [Nm]	$\left[\frac{20,5}{R} \right] + C_s$	$\left[\frac{49,2}{R} \right] + C_s$	$\left[\frac{113,2}{R} \right] + C_s$
		R = rapporto di riduzione del riduttore / rinvio angolare R = planetary / angle bevel gearbox reduction ratio		
C_{m,max}	"CASO 3" / "CASE 3": B00 + R00/R01 [Nm]	$\frac{20,5}{R}$	$\frac{49,2}{R}$	$\frac{113,2}{R}$
		R = rapporto di riduzione della trasmissione a cinghia (disponibile R=1 oppure R=2) R = belt gearbox reduction ratio (available R=1 or R=2)		
	"CASO 4" / "CASE 4": B00 + R02 [Nm]	$\frac{22,7}{R}$	$\frac{54,6}{R}$	$\frac{125,7}{R}$
		R = rapporto di riduzione del riduttore epicicloidale R = planetary gearbox reduction ratio		
F_{st}	CARICO MASSIMO STATICO APPLICABILE MAX ADMISSIBLE STATIC LOAD [N]	30000	30000	30000
V_{out,max}	VELOCITÀ DI TRASLAZIONE MASSIMA IN USCITA / ROTAZIONE MASSIMA VITE RDS [mm/sec]	250/3000	500/3000	1600/3000
N_{in,max}	MAX OUTPUT SPEED / MAX BALLSCREW ROTATING INPUT SPEED [rpm]			
a_{max}	ACCELERAZIONE MASSIMA IN USCITA MAX OUTPUT ACCELERATION [m/sec ²]	1	2	5
S_{max}	CORSA MASSIMA STANDARD MAX STANDARD STROKE [mm]	1000**	1000**	1000**
	PESO MODULO BASE CORSA 0 mm / PESO OGNI 100 mm DI CORSA BASIC MODULE WEIGHT FOR 0 mm STROKE / WEIGHT FOR ADDITIONAL 100 mm STROKE [Kg]	5,6 / 1,8	5,6 / 1,8	5,6 / 1,8
G_{s,max}	GIOCO ASSIALE MASSIMO PER CHIOCCIOLA STANDARD MAX AXIAL BACKLASH FOR STANDARD BALLSCREW ASSEMBLY mm	0,06	0,06	0,02
G_z	GIOCO "0" DELLA CHIOCCIOLA "0" BACKLASH BALLSCREW ASSEMBLY	DISPONIBILE / AVAILABLE		
L_{10,Km}	DURATA LIFETIME Km	VEDI TABELLA / SEE TABLE pg. 88		





* Per le versioni R00/R01 controllare con i grafici delle pagine 90/91. / For R00/R01 types please check graph at pages 90/91.

** Per corse superiori, contattare il nostro servizio tecnico. / For longer strokes please contact our technical dept.

ISOMOVE IE 80 HL		5	10	32
VERSIONI DISPONIBILI AVAILABLE TYPES		D00 / D01 / D02 / R00 / R01 / R02 / A01		
F_{a,p}	POSSIBILE CON IL RIDUTTORE EPICICLOIDALE INDICATO POSSIBLE VALUE WITH THE INDICATED PLANETARY GEARBOX [N]	AE070/21000 AE090/21000 PGII-080/21000 PGII-120/21000	AE070/18000 AE090/25000 PGII-080/25000 PGII-120/25000	AE070/5500 *** AE090/13800*** PGII-080/8900 *** PGII-120/18000
	POSSIBILE CON IL RINVIO ANGOLARE INDICATO POSSIBLE VALUE WITH THE INDICATED ANGLE BEVEL GEARBOX [N]	ATB090/21000 ATB110/21000	ATB090/21000 ATB110/25000	ATB090/4500 *** ATB110/11600 ***
ACCESSORI DISPONIBILI AVAILABLE ACCESSORIES		VEDI PARAGRAFO / SEE PARAGRAPH 3.10 (pg. 136)		

*** È il valore massimo ottenibile con il rapporto di riduzione disponibile avente il minore valore di coppia erogabile.
It is the max obtainable value with the available on tables reduction ratio which has the lowest value of nominal output torque.

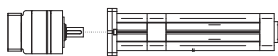
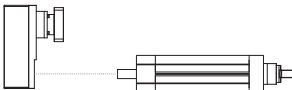
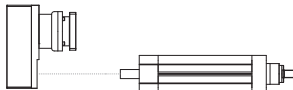
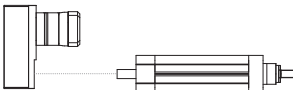
RIDUTTORI-RINVII "STANDARD SETEC GROUP DISPONIBILI"
"STANDARD SETEC GROUP AVAILABLE" PLANETARY-ANGLE BEVEL GEARBOXES

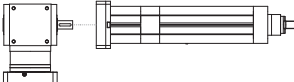
<p>TRASMISSIONE COASSIALE CON RIDUTTORE IN-LINE PLANETARY GEARBOX STAGE</p>	 AE070 MODULO BASE BASIC MODULE	 AE090 MODULO BASE BASIC MODULE	
	 PGII-080 MODULO BASE BASIC MODULE	 PGII-120 MODULO BASE BASIC MODULE	
<p>TRASMISSIONE PARALLELA CON RIDUTTORE PARALLEL BELT GEARBOX STAGE + IN-LINE PLANETARY GEARBOX REDUCTION STAGE</p>	 AE070 MODULO BASE BASIC MODULE	 AE090 MODULO BASE BASIC MODULE	 PGII-080 MODULO BASE BASIC MODULE
<p>TRASMISSIONE ANGOLARE CON RINVIO ANGLE BEVEL GEARBOX STAGE</p>	 ATB090 MODULO BASE BASIC MODULE	 ATB110 MODULO BASE BASIC MODULE	

3.6.2 Calcolo durata

3.6.2 Lifetime calculation

IE 80 HL P = 5 mm	$L_{10,Km} = \left[\frac{23900}{F_{eq}} \right]^3 \cdot 5$	$L_{10,Km} = [Km]$ $F_{eq} = [N]$
IE 80 HL P = 10 mm	$L_{10,Km} = \left[\frac{31500}{F_{eq}} \right]^3 \cdot 10$	$L_{10,Km} = [Km]$ $F_{eq} = [N]$
IE 80 HL P = 32 mm	$L_{10,Km} = \left[\frac{20600}{F_{eq}} \right]^3 \cdot 32$	$L_{10,Km} = [Km]$ $F_{eq} = [N]$

3.6.3 Calcolo coppia in ingresso
al modulo base3.6.3 Torque calculation at basic
module input shaft

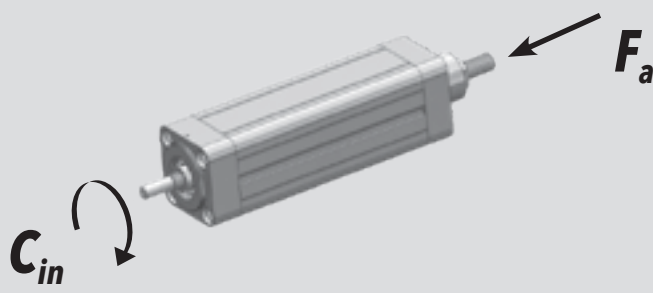



The diagram shows a perspective view of a motor module. A curved arrow labeled C_{in} indicates the input torque at the front shaft. A straight arrow labeled F_a points towards the rear shaft, representing the axial force.

IE 80 HL P = 5 mm	$C_{in} = \left[\frac{F_a \cdot 5}{5652} \right]$	$C_{in} = [Nm]$ $F_a = [N]$
IE 80 HL P = 10 mm	$C_{in} = \left[\frac{F_a \cdot 10}{5652} \right]$	$C_{in} = [Nm]$ $F_a = [N]$
IE 80 HL P = 32 mm	$C_{in} = \left[\frac{F_a \cdot 32}{5652} \right]$	$C_{in} = [Nm]$ $F_a = [N]$

3.6.4 Calcolo coppia motore

3.6.4 Motor torque calculation

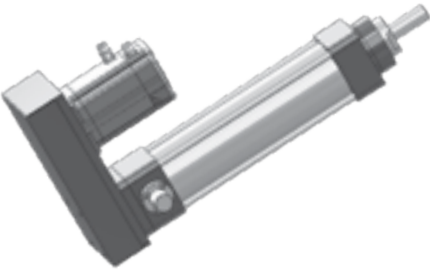
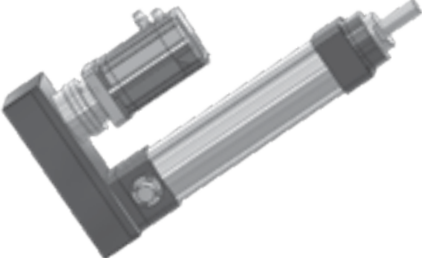
<p>CASO / CASE 1</p>	<p>ISOMOVE B00 + D00 / D01</p>  $C_m = C_{in} \quad [Nm]$
<p>CASO / CASE 2</p>	<p>ISOMOVE B00 + D02 / A01</p>  $C_m = \left[\frac{C_{in}}{R \cdot \eta} \right] + C_s \quad [Nm]$ <p><i>R</i> = rapporto di riduzione riduttore / rinvio planetary / angle bevel gearbox reduction ratio <i>η</i> = rendimento meccanico / mechanical efficiency = 0,90</p>
<p>CASO / CASE 3</p>	<p>ISOMOVE B00 + R00 / R01</p>  $C_m = \left[\frac{C_{in}}{R \cdot \eta} \right] \quad [Nm]$ <p><i>R</i> = rapporto di riduzione trasmissione a cinghia, disponibile R=1 o R=2 belt gearbox reduction ratio, available R=1 or R=2 <i>η</i> = rendimento meccanico / mechanical efficiency = 0,90</p>
<p>CASO / CASE 4</p>	<p>ISOMOVE B00 + R02</p>  $C_m = \left[\frac{C_{in}}{R \cdot \eta} \right] + C_s \quad [Nm]$ <p><i>R</i> = rapporto di riduzione riduttore epicicloidale planetary gearbox reduction ratio <i>η</i> = rendimento meccanico / mechanical efficiency = 0,81</p>

3.6.5 Potenza in ingresso alla trasmissione a cinghia (versione R)

3.6.5 Mechanical input power at belt gear stage (R type)

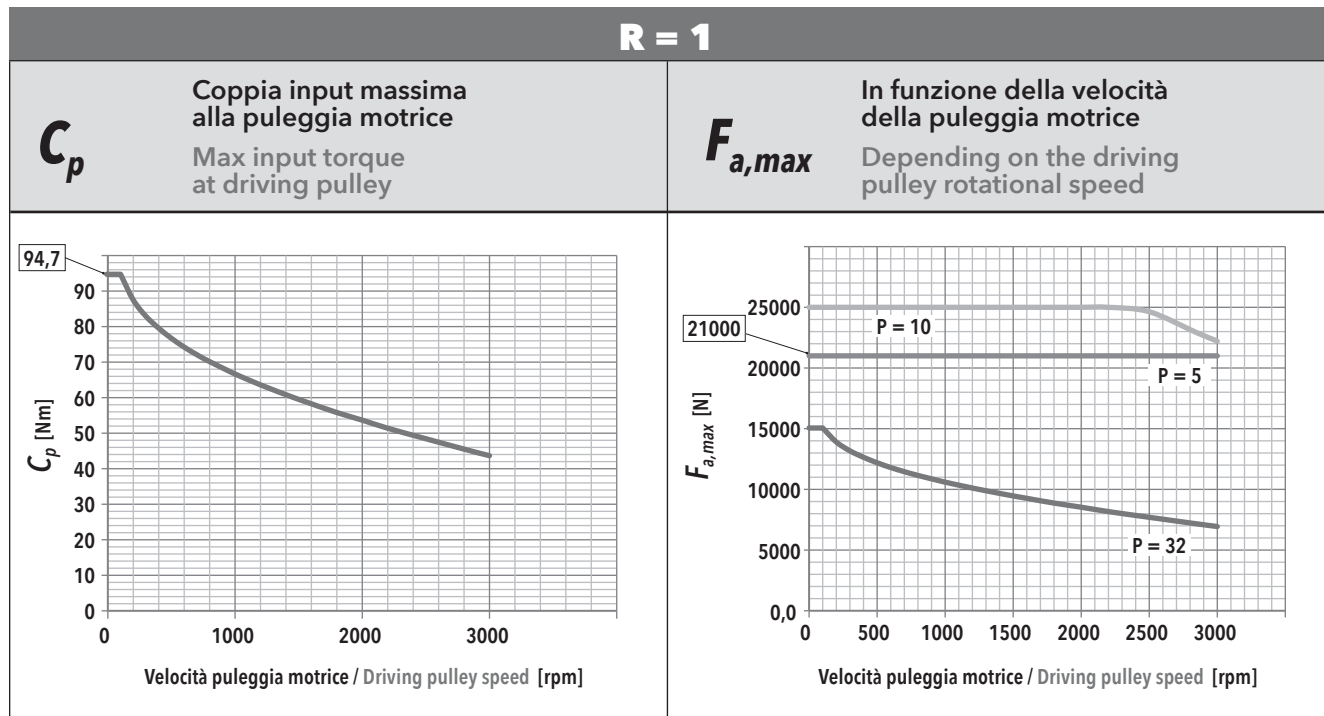

IE 80 HL - PASSO / PITCH 5						IE 80 HL - PASSO / PITCH 10						IE 80 HL - PASSO / PITCH 32					
F_a [N]		V_{out} [mm/s]				F_a [N]		V_{out} [mm/s]				F_a [N]		V_{out} [mm/s]			
		25	100	175	250			50	200	350	500			160	640	1120	1600
21000	F_r [N]	616	622	634	652	25000	F_r [N]	1467	1469	1473		18000	F_r [N]				
	f_t [Hz]	207	208	210	213		f_t [Hz]	320	320	320			f_t [Hz]				
18900	F_r [N]	555	560	572	590	22500	F_r [N]	1321	1322	1326	1356	16200	F_r [N]				
	f_t [Hz]	197	198	200	203		f_t [Hz]	303	304	304	307		f_t [Hz]				
16800	F_r [N]	493	499	510	529	20000	F_r [N]	1174	1176	1179	1209	14400	F_r [N]				
	f_t [Hz]	185	186	189	192		f_t [Hz]	286	286	287	290		f_t [Hz]				
14700	F_r [N]	432	437	449	467	17500	F_r [N]	1027	1029	1033	1063	12600	F_r [N]	2366			
	f_t [Hz]	173	175	177	180		f_t [Hz]	268	268	268	272		f_t [Hz]	406			
12600	F_r [N]	370	375	387	406	15000	F_r [N]	881	882	886	916	10800	F_r [N]	2028	2034		
	f_t [Hz]	161	162	164	168		f_t [Hz]	248	248	249	253		f_t [Hz]	376	377		
10500	F_r [N]	308	314	326	344	12500	F_r [N]	734	736	739	769	9000	F_r [N]	1690	1696	1707	
	f_t [Hz]	147	148	151	155		f_t [Hz]	226	226	227	232		f_t [Hz]	343	344	345	
8400	F_r [N]	247	252	264	282	10000	F_r [N]	587	589	593	623	7200	F_r [N]	1352	1358	1369	1388
	f_t [Hz]	131	133	136	140		f_t [Hz]	202	203	203	208		f_t [Hz]	307	308	309	311
6300	F_r [N]	185	191	202	221	7500	F_r [N]	440	442	446	476	5400	F_r [N]	1050	1020	1031	1050
	f_t [Hz]	114	115	119	124		f_t [Hz]	175	176	176	182		f_t [Hz]	271	267	268	271
4200	F_r [N]	124	129	141	159	5000	F_r [N]	294	296	299	329	3600	F_r [N]	676	682	694	712
	f_t [Hz]	93	95	99	105		f_t [Hz]	143	144	144	152		f_t [Hz]	217	218	220	223
2100	F_r [N]	62	67	79	97	2500	F_r [N]	147	149	152	183	1800	F_r [N]	676	682	694	712
	f_t [Hz]	66	69	74	82		f_t [Hz]	101	102	103	113		f_t [Hz]	217	218	220	223

R = 2

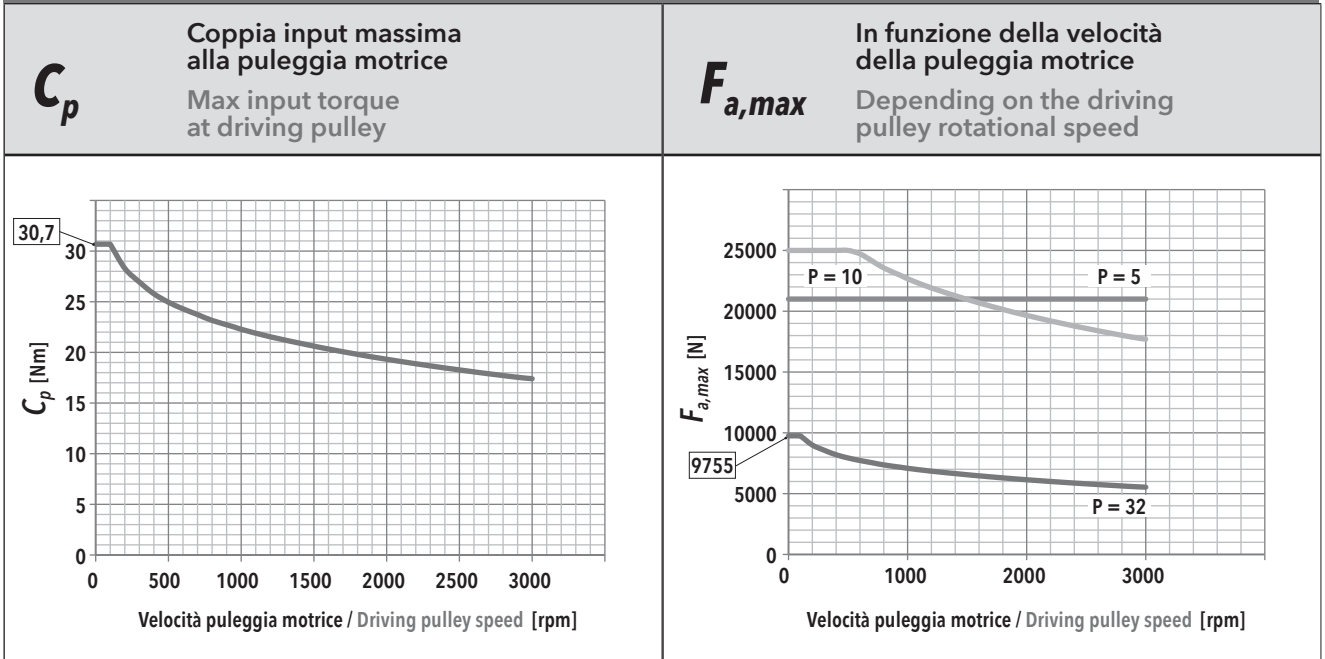

F_r Forza radiale su asse puleggia motrice in funzione di C_{in}
Radial force on driving pulley as a function of C_{in}

f_t Frequenza di vibrazione della cinghia per il tensionamento (al montaggio)
Vibration frequency of the belt for its tensioning (during assembly)

IE 80 HL - PASSO / PITCH 5					IE 80 HL - PASSO / PITCH 10					IE 80 HL - PASSO / PITCH 32							
F_a [N]		V_{out} [mm/s]				F_a [N]		V_{out} [mm/s]				F_a [N]		V_{out} [mm/s]			
		12,5	50	87,5	125			25	100	175	250			80	320	560	800
21000	F_r [N]	635	637	638	641	25000	F_r [N]	1512				18000	F_r [N]				
	f_t [Hz]	256	256	257	257		f_t [Hz]	395					f_t [Hz]				
18900	F_r [N]	572	574	576	578	22500	F_r [N]	1361	1362			16200	F_r [N]				
	f_t [Hz]	243	243	244	244		f_t [Hz]	375	375				f_t [Hz]				
16800	F_r [N]	508	510	512	514	20000	F_r [N]	1210	1211	1213		14400	F_r [N]				
	f_t [Hz]	229	229	230	230		f_t [Hz]	353	353	354			f_t [Hz]				
14700	F_r [N]	445	448	450	451	17500	F_r [N]	1059	1061	1063	1065	12600	F_r [N]				
	f_t [Hz]	214	214	216	216		f_t [Hz]	330	330	331	331		f_t [Hz]				
12600	F_r [N]	381	384	386	387	15000	F_r [N]	907	910	911	913	10800	F_r [N]				
	f_t [Hz]	198	198	200	200		f_t [Hz]	306	306	307	307		f_t [Hz]				
10500	F_r [N]	318	320	322	324	12500	F_r [N]	756	758	760	762	9000	F_r [N]	1742			
	f_t [Hz]	181	181	182	183		f_t [Hz]	279	279	280	280		f_t [Hz]	424			
8400	F_r [N]	254	254	260	260	10000	F_r [N]	605	608	610	611	7200	F_r [N]	1394	1395		
	f_t [Hz]	162	162	164	164		f_t [Hz]	250	250	251	251		f_t [Hz]	379	379		
6300	F_r [N]	191	194	196	197	7500	F_r [N]	454	456	458	460	5400	F_r [N]	1045	1046	1048	
	f_t [Hz]	140	140	142	142		f_t [Hz]	216	216	218	218		f_t [Hz]	328	328	329	
4200	F_r [N]	127	130	131	133	5000	F_r [N]	303	306	307	309	3600	F_r [N]	697	698	700	703
	f_t [Hz]	114	114	117	117		f_t [Hz]	177	177	178	178		f_t [Hz]	268	268	269	269
2100	F_r [N]	64	66	68	70	2500	F_r [N]	151	153	155	157	1800	F_r [N]	348	350	352	355
	f_t [Hz]	81	81	85	85		f_t [Hz]	125	125	127	127		f_t [Hz]	190	190	191	191

3.6.6 Caratteristiche dimensionali

3.6.6 Overall dimensions

NOTA: Dati categorie motori / riduttori / rinvi al capitolo 4.

REMARK: Motors / Planetary / Angle bevel gearbox categories data at chapter 4.

B00
MODULO BASE
BASIC MODULE

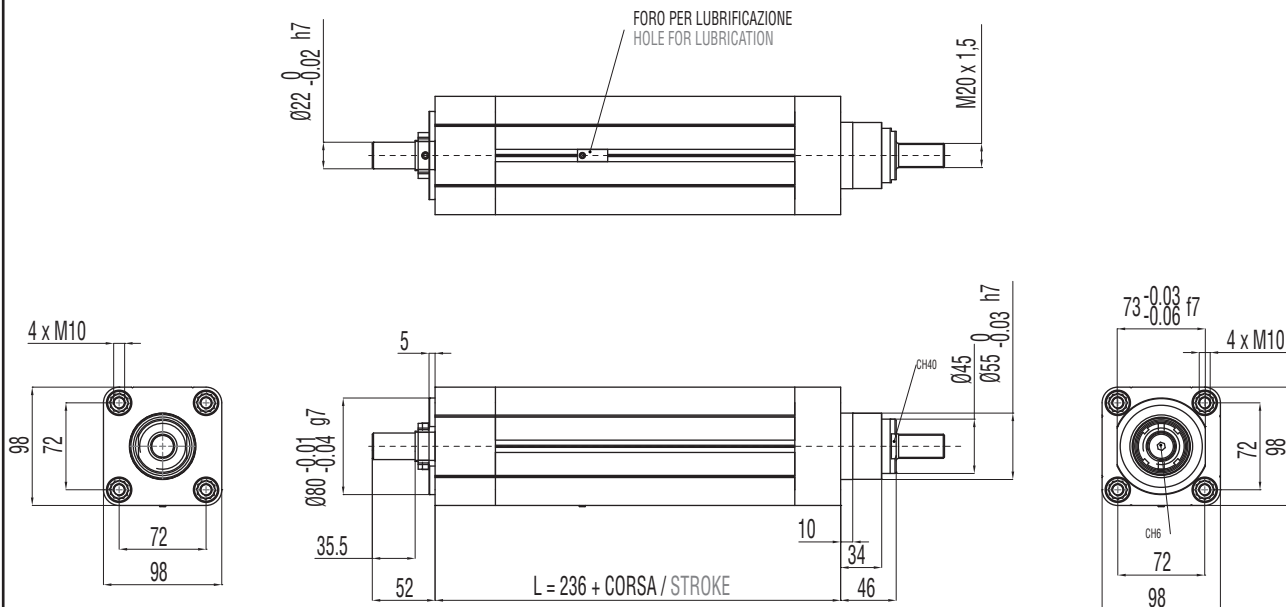
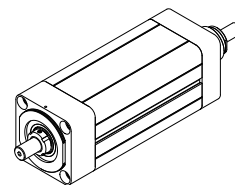

B00 + D00

MODULO BASE + TRASMISSIONE COASSIALE PER MOTORE CUSTOM
(SENZA RIDUTTORE)

**BASIC MODULE + CUSTOM IN-LINE TRANSMISSION W/O REDUCTION STAGE
FOR CUSTOM MOTORS**

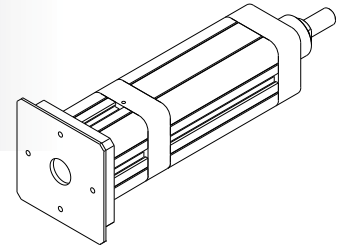

CxC	B	DIMENSIONI LIMITI INTERFACCIA MAX INTERFACE DIMENSIONS			
		TAGLIA GIUNTO COUPLING SIZE	A [mm]	B [mm]	C [mm]
		60	30 max	28 min / 50 max	110 max

NOTA: Massima coppia in ingresso al giunto pari a 75 Nm.
REMARK: Max admissible input torque at coupling = 75 Nm.

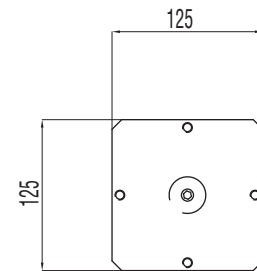
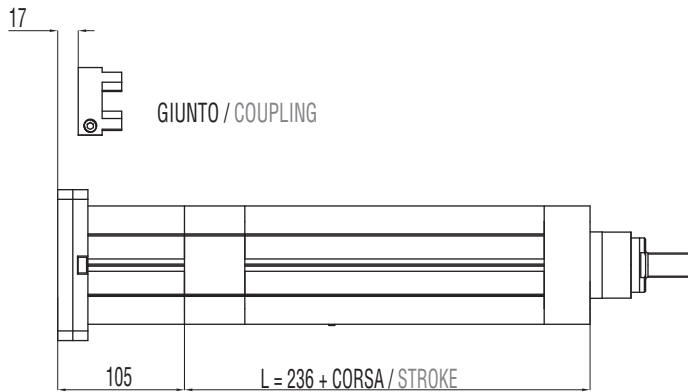

B00 + D01

MODULO BASE + TRASMISSIONE COASSIALE PER MOTORE COMPATIBILE
(SENZA RIDUTTORE)

**BASIC MODULE + IN-LINE TRANSMISSION W/O REDUCTION STAGE FOR
COMPATIBLE MOTORS**

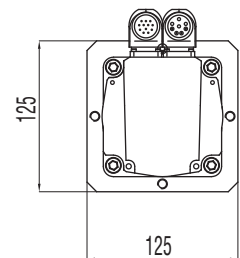
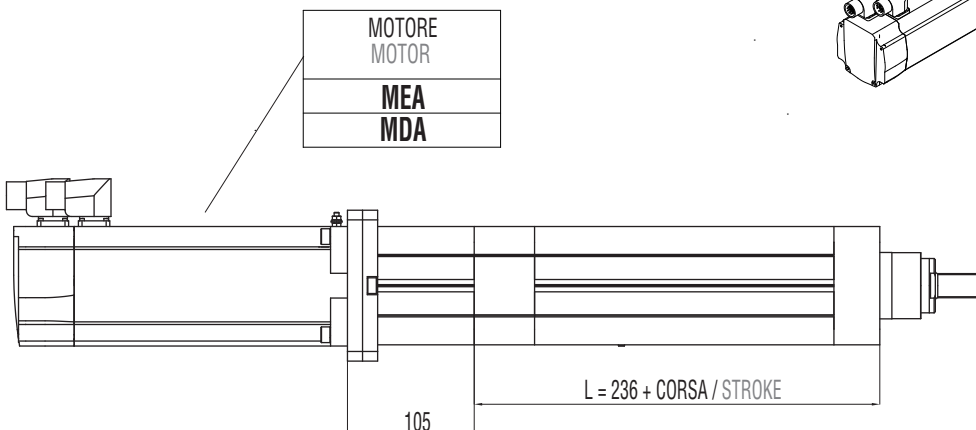
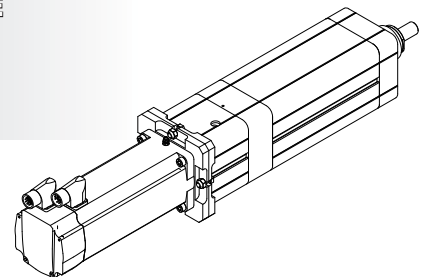

B00 + D02

MODULO BASE + RIDUTTORE EPICICLOIDALE COASSIALE COMPATIBILE

BASIC MODULE + IN-LINE COMPATIBLE PLANETARY GEARBOX REDUCTION STAGE

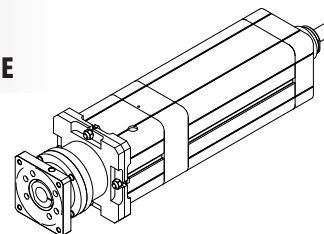

RIDUTTORE PLANETARY GEARBOX
GCA
GDA
GCB
GEB*

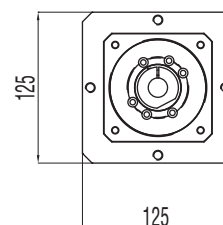
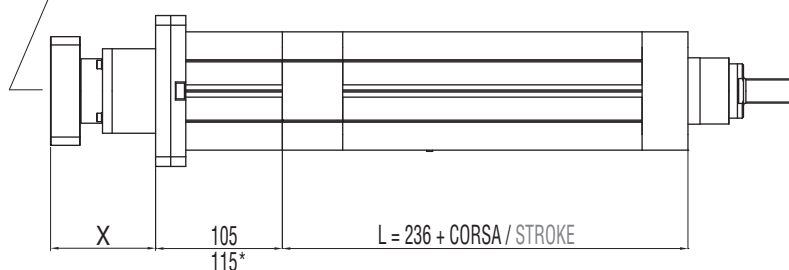

B00 + A01

MODULO BASE + RINVIO ANGOLARE COMPATIBILE

BASIC MODULE + COMPATIBLE ANGLE BEVEL GEARBOX STAGE

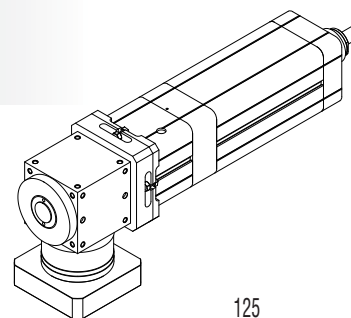

RINVIO ANGOLARE ANGLE BEVEL GEARBOX
ACA*
ADA**

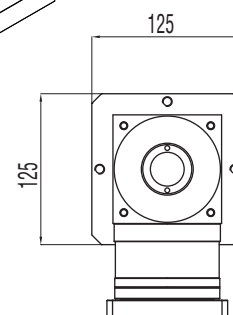
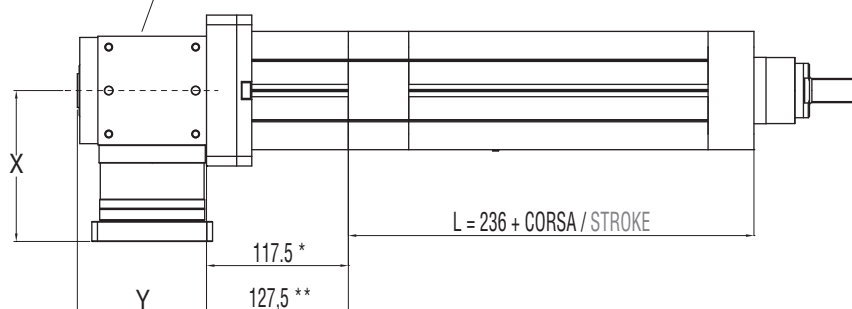

B00 + R00

MODULO BASE + TRASMISSIONE A CINGHIA IN PARALLELO PER MOTORE CUSTOM

BASIC MODULE + PARALLEL CUSTOM BELT GEARBOX STAGE FOR CUSTOM MOTORS

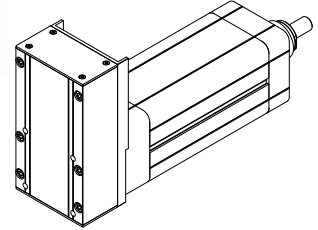

	DIMENSIONI LIMITI INTERFACCIA MAX INTERFACE DIMENSIONS		
	A	B	C
	[mm]	[mm]	[mm]
R=1:1	24 max	42 min / 58 max	110 max
R=1:2	19 max	36 min / 50 max	110 max

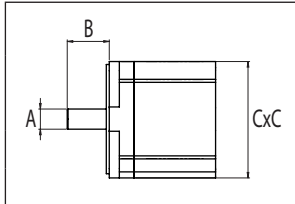

RAPPORTO / RATIO	1:1	1:2
PASSO / PITCH	8 mm	5 mm
Z = DENTI / TEETH	30	24
DIAMETRO PRIMITIVO PULEGGIA MOTRICE DRIVING PULLEY PITCH DIAMETER	76,39 mm	38,2 mm

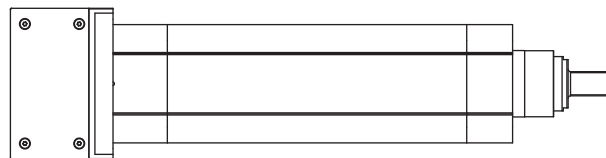
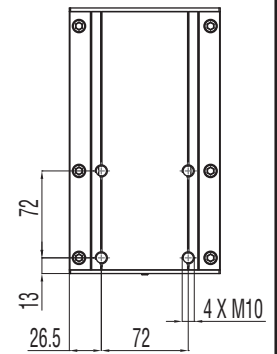
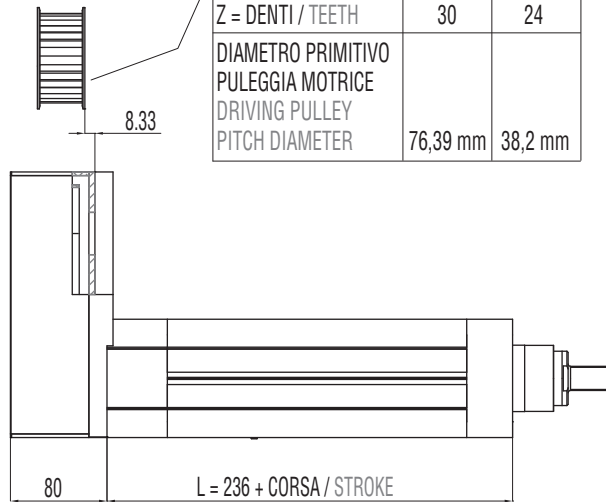
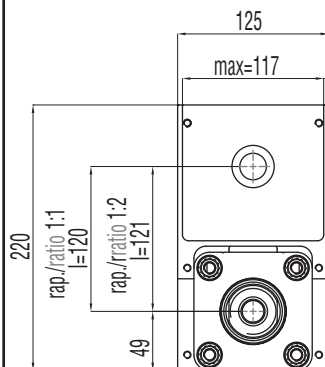

B00 + R01

MODULO BASE + TRASMISSIONE A CINGHIA IN PARALLELO PER MOTORE COMPATIBILE

BASIC MODULE + PARALLEL BELT GEARBOX STAGE FOR COMPATIBLE MOTORS

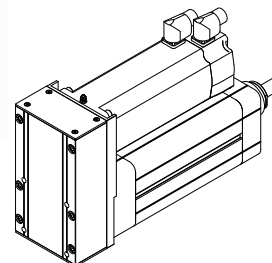

MOTORE MOTOR
MCA
MCB
MCC
MCD
MDA
MDB
MDC

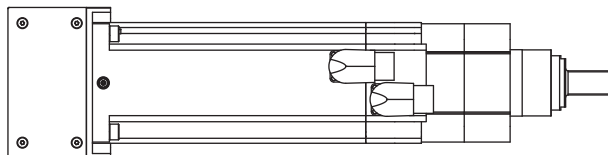
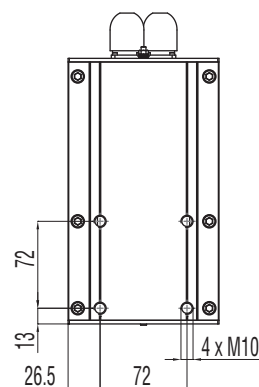
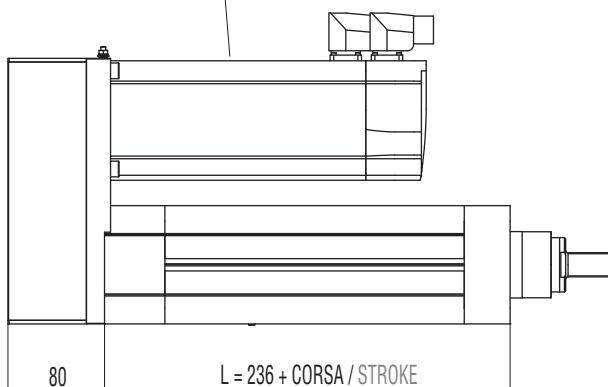
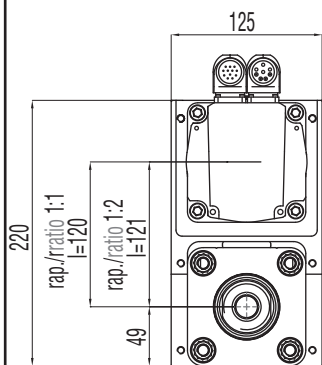

B00 + R02

MODULO BASE + TRASMISSIONE A CINGHIA IN PARALLELO +
RIDUTTORE EPICICLOIDALE COMPATIBILE

**BASIC MODULE + PARALLEL BELT GEARBOX STAGE +
IN-LINE COMPATIBLE PLANETARY GEARBOX REDUCTION STAGE**

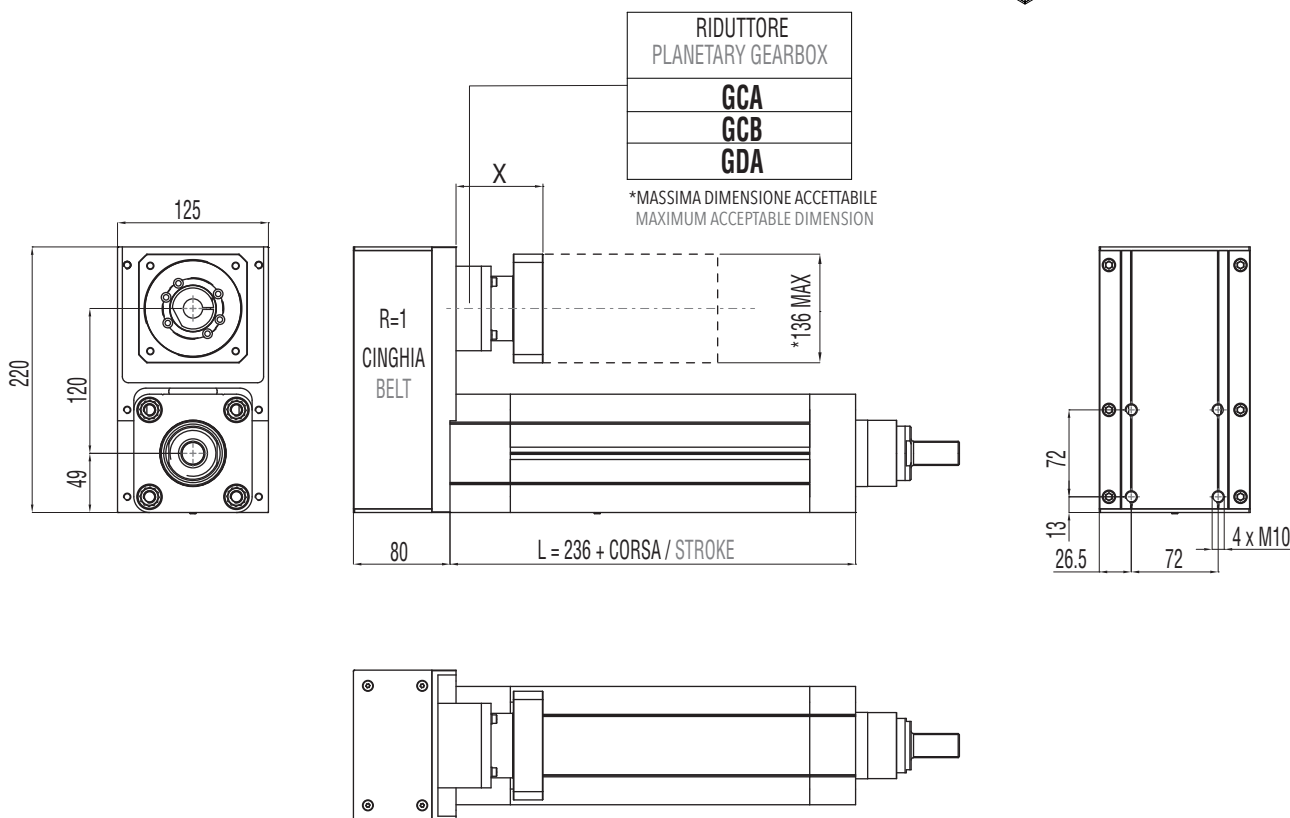
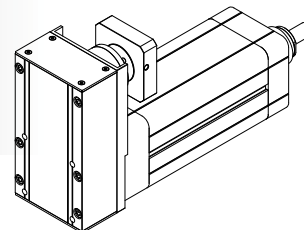

3.6.7 Accessori disponibili

Per le tabelle e i disegni tecnici degli accessori disponibili fare riferimento al paragrafo 3.10 (da pag. 136).

3.6.7 Available accessories

For tables and drawings please refer to paragraph 3.10 (from page 136).

3.7

IE 100

3.7.1 Caratteristiche tecniche

3.7.1 Technical features

ISOMOVE IE 100		5	10	20	32
P	PASSO VITE SCREW LEAD [mm]	5	10	20	32
D	DIAMETRO VITE SCREW DIAMETER [mm]	32	32	32	32
F_d	CARICO MASSIMO DINAMICO APPLICABILE MAX ADMISSIBLE DYNAMIC LOAD [N]	21000*	25000*	30000*	16000*
C_{in,max}	PER AVERE $F_a = F_d$ TO GET [Nm]	18,5	44,3	106	90,5
	"CASO 1" / "CASE 1": B00 + D00/D01 [Nm]	18,5	44,3	106	90,5
	"CASO 2" / "CASE 2": B00 + D02/A01 [Nm]	$\left[\frac{20,5}{R} \right] + C_s$	$\left[\frac{49,2}{R} \right] + C_s$	$\left[\frac{117}{R} \right] + C_s$	$\left[\frac{100}{R} \right] + C_s$
		R = rapporto di riduzione del riduttore / rinvio angolare R = planetary / angle bevel gearbox reduction ratio			
C_{m,max}	"CASO 3" / "CASE 3": B00 + R00/R01 [Nm]	$\frac{20,5}{R}$	$\frac{49,2}{R}$	$\frac{117}{R}$	$\frac{100}{R}$
		R = rapporto di riduzione della trasmissione a cinghia (disponibile R=1 oppure R=2) R = belt gearbox reduction ratio (available R=1 or R=2)			
	"CASO 4" / "CASE 4": B00 + R02 [Nm]	$\frac{22,7}{R}$	$\frac{54,6}{R}$	$\frac{130}{R}$	$\frac{111}{R}$
		R = rapporto di riduzione del riduttore epicicloidale R = planetary gearbox reduction ratio			
F_{st}	CARICO MASSIMO STATICO APPLICABILE MAX ADMISSIBLE STATIC LOAD [N]	30000	30000	30000	30000
V_{out,max}	VELOCITÀ DI TRASLAZIONE MASSIMA IN USCITA / ROTAZIONE MASSIMA VITE RDS [mm/sec]	250/3000	500/3000	1000/3000	1600/3000
N_{in,max}	MAX OUTPUT SPEED / MAX BALLSCREW ROTATING INPUT SPEED [rpm]	250/3000	500/3000	1000/3000	1600/3000
a_{max}	ACCELERAZIONE MASSIMA IN USCITA MAX OUTPUT ACCELERATION [m/sec ²]	1	2	3	5
S_{max}	CORSA MASSIMA STANDARD MAX STANDARD STROKE [mm]	1100**	1100**	1100**	1100**
	PESO MODULO BASE CORSA 0 mm / PESO OGNI 100 mm DI CORSA BASIC MODULE WEIGHT FOR 0 mm STROKE / WEIGHT FOR ADDITIONAL 100 mm STROKE [Kg]	7,1 / 2,3	7,1 / 2,3	7,1 / 2,3	7,1 / 2,3
G_{s,max}	GIOCO ASSIALE MASSIMO PER CHIOCCIOLA STANDARD MAX AXIAL BACKLASH FOR STANDARD BALLSCREW ASSEMBLY mm	0,06	0,06	0,06	0,06
G_z	GIOCO "0" DELLA CHIOCCIOLA "0" BACKLASH BALLSCREW ASSEMBLY	DISPONIBILE / AVAILABLE			
L_{10,Km}	DURATA LIFETIME Km	VEDI TABELLA / SEE TABLE pg. 100			







* Per le versioni R00/R01 controllare con i grafici delle pagine 102/103. / For R00/R01 types please check graph at pages 102/103.

** Per corse superiori, contattare il nostro servizio tecnico. / For longer strokes please contact our technical dpt.

ISOMOVE IE 100		5	10	20	32
VERSIONI DISPONIBILI AVAILABLE TYPES		D00 / D01 / D02 / R00 / R01 / R02 / A01			
F_{a,p}	POSSIBILE CON IL RIDUTTORE EPICICLOIDALE INDICATO POSSIBLE VALUE WITH THE INDICATED PLANETARY GEARBOX [N]	AE070/21000 AE090/21000 PGII-080/21000 PGII-120/21000	AE070/18000 AE090/25000 PGII-080/25000 PGII-120/25000	AE070/8800 *** AE090/21900*** PGII-080/14300 *** PGII-120/30000	AE070/8800 *** AE090/21900*** PGII-080/14300 *** PGII-120/30000
	POSSIBILE CON IL RINVIO ANGOLARE INDICATO POSSIBLE VALUE WITH THE INDICATED ANGLE BEVEL GEARBOX [N]	ATB090/21000 ATB110/21000	ATB090/21000*** ATB110/25000	ATB090/4500 *** ATB110/11600 ***	ATB090/4500 *** ATB110/11600 ***
ACCESSORI DISPONIBILI AVAILABLE ACCESSORIES		VEDI PARAGRAFO / SEE PARAGRAPH 3.10 (pg. 136)			

*** È il valore massimo ottenibile con il rapporto di riduzione disponibile avente il minore valore di coppia erogabile.
It is the max obtainable value with the available on tables reduction ratio which has the lowest value of nominal output torque.

RIDUTTORI-RINVII "STANDARD SETEC GROUP DISPONIBILI"
"STANDARD SETEC GROUP AVAILABLE" PLANETARY-ANGLE BEVEL GEARBOXES

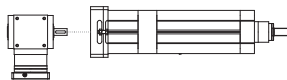
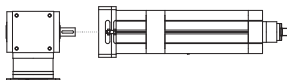
<p>TRASMISSIONE COASSIALE CON RIDUTTORE IN-LINE PLANETARY GEARBOX STAGE</p>	 AE070 MODULO BASE BASIC MODULE	 AE090 MODULO BASE BASIC MODULE	
	 PGII-080 MODULO BASE BASIC MODULE	 PGII-120 MODULO BASE BASIC MODULE	
<p>TRASMISSIONE PARALLELA CON RIDUTTORE PARALLEL BELT GEARBOX STAGE + IN-LINE PLANETARY GEARBOX REDUCTION STAGE</p>	 AE070 MODULO BASE BASIC MODULE	 AE090 MODULO BASE BASIC MODULE	 PGII-080 MODULO BASE BASIC MODULE
<p>TRASMISSIONE ANGOLARE CON RINVIO ANGLE BEVEL GEARBOX STAGE</p>	 ATB090 MODULO BASE BASIC MODULE	 ATB110 MODULO BASE BASIC MODULE	

3.7.2 Calcolo durata

3.7.2 Lifetime calculation

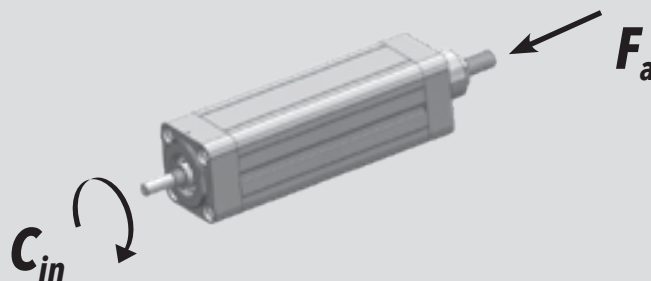

IE 100 P = 5 mm	$L_{10,Km} = \left[\frac{23900}{F_{eq}} \right]^3 \cdot 5$	$L_{10,Km} = [Km]$ $F_{eq} = [N]$
IE 100 P = 10 mm	$L_{10,Km} = \left[\frac{31500}{F_{eq}} \right]^3 \cdot 10$	$L_{10,Km} = [Km]$ $F_{eq} = [N]$
IE 100 P = 20 mm	$L_{10,Km} = \left[\frac{39300}{F_{eq}} \right]^3 \cdot 20$	$L_{10,Km} = [Km]$ $F_{eq} = [N]$
IE 100 P = 32 mm	$L_{10,Km} = \left[\frac{18200}{F_{eq}} \right]^3 \cdot 32$	$L_{10,Km} = [Km]$ $F_{eq} = [N]$

3.7.3 Calcolo coppia in ingresso
al modulo base3.7.3 Torque calculation at basic
module input shaft

IE 100 P = 5 mm	$C_{in} = \left[\frac{F_a \cdot 5}{5652} \right]$	$C_{in} = [Nm]$ $F_a = [N]$
IE 100 P = 10 mm	$C_{in} = \left[\frac{F_a \cdot 10}{5652} \right]$	$C_{in} = [Nm]$ $F_a = [N]$
IE 100 P = 20 mm	$C_{in} = \left[\frac{F_a \cdot 20}{5652} \right]$	$C_{in} = [Nm]$ $F_a = [N]$
IE 100 P = 32 mm	$C_{in} = \left[\frac{F_a \cdot 32}{5652} \right]$	$C_{in} = [Nm]$ $F_a = [N]$

3.7.4 Calcolo coppia motore

3.7.4 Motor torque calculation

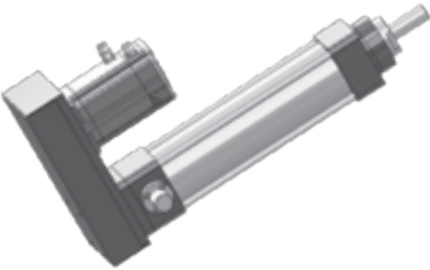
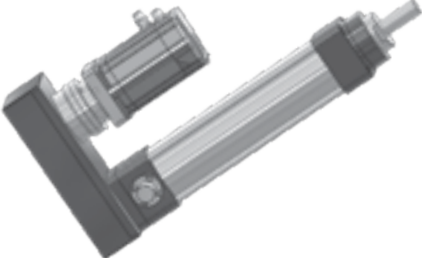
<p>CASO / CASE 1</p>	<p>ISOMOVE B00 + D00 / D01</p>  $C_m = C_{in} \quad [Nm]$
<p>CASO / CASE 2</p>	<p>ISOMOVE B00 + D02 / A01</p>  $C_m = \left[\frac{C_{in}}{R \cdot \eta} \right] + C_s \quad [Nm]$ <p>R = rapporto di riduzione riduttore / rinvio planetary / angle bevel gearbox reduction ratio η = rendimento meccanico / mechanical efficiency = 0,90</p>
<p>CASO / CASE 3</p>	<p>ISOMOVE B00 + R00 / R01</p>  $C_m = \left[\frac{C_{in}}{R \cdot \eta} \right] \quad [Nm]$ <p>R = rapporto di riduzione trasmissione a cinghia, disponibile R=1 o R=2 belt gearbox reduction ratio, available R=1 or R=2 η = rendimento meccanico / mechanical efficiency = 0,90</p>
<p>CASO / CASE 4</p>	<p>ISOMOVE B00 + R02</p>  $C_m = \left[\frac{C_{in}}{R \cdot \eta} \right] + C_s \quad [Nm]$ <p>R = rapporto di riduzione riduttore epicicloidale planetary gearbox reduction ratio η = rendimento meccanico / mechanical efficiency = 0,81</p>

3.7.5 Potenza in ingresso alla trasmissione a cinghia (versione R)

3.7.5 Mechanical input power at belt gear stage (R type)

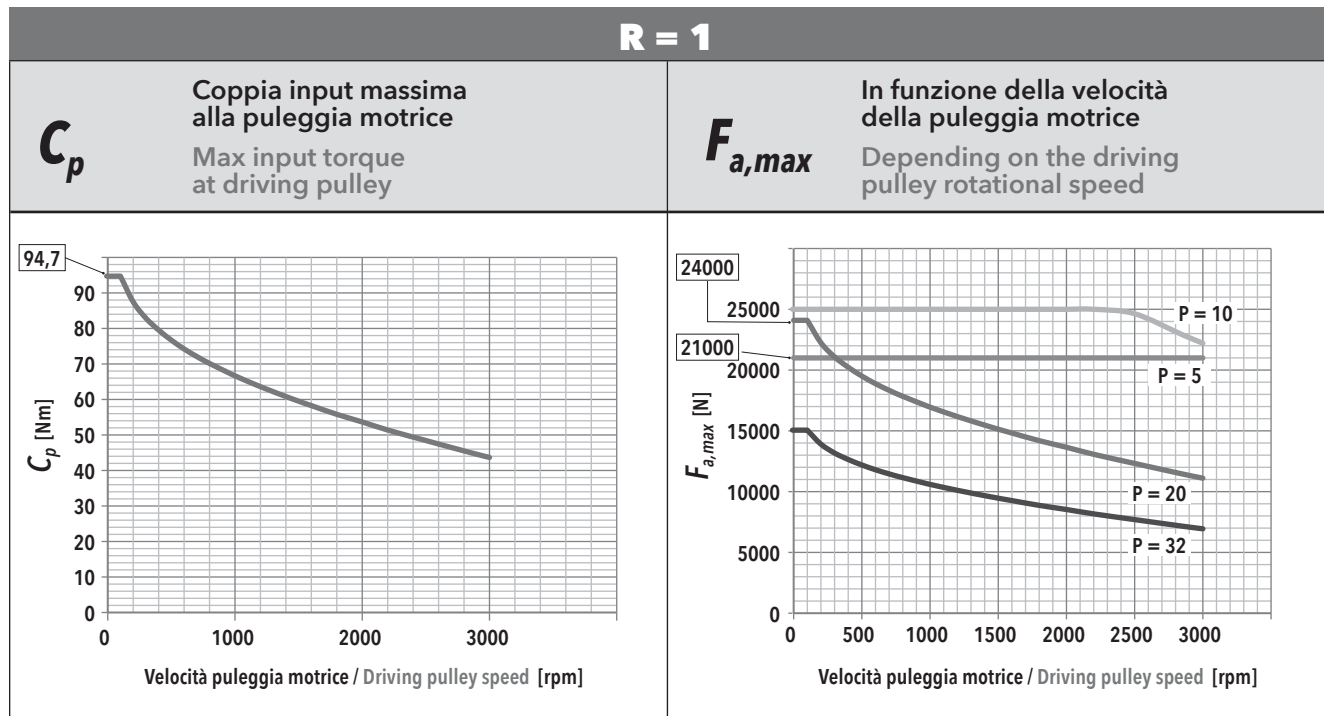

IE 100 - PASSO / PITCH 5					IE 100 - PASSO / PITCH 10					IE 100 - PASSO / PITCH 20					IE 100 - PASSO / PITCH 32								
F_a [N]		V_{out} [mm/s]				F_a [N]		V_{out} [mm/s]				F_a [N]		V_{out} [mm/s]				F_a [N]		V_{out} [mm/s]			
		25	100	175	250			50	200	350	500			100	400	700	1000			160	640	1120	1600
21000	F_r [N]	616	622	634	652	25000	F_r [N]	1467	1469	1473	30000	F_r [N]					16000	F_r [N]					
	f_t [Hz]	207	208	210	213		f_t [Hz]	320	320	320		f_t [Hz]						f_t [Hz]					
18900	F_r [N]	555	560	572	590	22500	F_r [N]	1321	1322	1326	1356	27000	F_r [N]					14400	F_r [N]				
	f_t [Hz]	197	198	200	203		f_t [Hz]	303	304	304	307		f_t [Hz]						f_t [Hz]				
16800	F_r [N]	493	499	510	529	20000	F_r [N]	1174	1176	1179	1209	24000	F_r [N]					12800	F_r [N]	2404			
	f_t [Hz]	185	186	189	192		f_t [Hz]	286	286	287	290		f_t [Hz]						f_t [Hz]	409			
14700	F_r [N]	432	437	449	467	17500	F_r [N]	1027	1029	1033	1063	21000	F_r [N]	2465				11200	F_r [N]	2103			
	f_t [Hz]	173	175	177	180		f_t [Hz]	268	268	268	272		f_t [Hz]	415					f_t [Hz]	383			
12600	F_r [N]	370	375	387	406	15000	F_r [N]	881	882	886	916	18000	F_r [N]	2113	2118			9600	F_r [N]	1803	1808		
	f_t [Hz]	161	162	164	168		f_t [Hz]	248	248	249	253		f_t [Hz]	384	384				f_t [Hz]	355	355		
10500	F_r [N]	308	314	326	344	12500	F_r [N]	734	736	739	769	15000	F_r [N]	1761	1766	1768		8000	F_r [N]	1502	1508	1520	
	f_t [Hz]	147	148	151	155		f_t [Hz]	226	226	227	232		f_t [Hz]	350	351	351			f_t [Hz]	324	324	325	
8400	F_r [N]	247	252	264	282	10000	F_r [N]	587	589	593	623	12000	F_r [N]	1409	1414	1416	1444	6400	F_r [N]	1202	1207	1219	1238
	f_t [Hz]	131	133	136	140		f_t [Hz]	202	203	203	208		f_t [Hz]	313	314	314	317		f_t [Hz]	289	290	292	294
6300	F_r [N]	185	191	202	221	7500	F_r [N]	440	442	446	476	9000	F_r [N]	1057	1062	1064	1092	4800	F_r [N]	902	907	919	937
	f_t [Hz]	114	115	119	124		f_t [Hz]	175	176	176	182		f_t [Hz]	271	272	272	276		f_t [Hz]	251	251	253	256
4200	F_r [N]	124	129	141	159	5000	F_r [N]	294	296	299	329	6000	F_r [N]	704	710	712	740	3200	F_r [N]	601	607	618	637
	f_t [Hz]	93	95	99	105		f_t [Hz]	143	144	144	152		f_t [Hz]	222	222	223	227		f_t [Hz]	205	206	208	211
2100	F_r [N]	62	67	79	97	2500	F_r [N]	147	149	152	183	3000	F_r [N]	352	358	360	388	1600	F_r [N]	301	306	318	336
	f_t [Hz]	66	69	74	82		f_t [Hz]	101	102	103	113		f_t [Hz]	157	158	158	164		f_t [Hz]	145	146	149	153

R = 2

C_p Coppia input massima alla puleggia motrice
Max input torque at driving pulley

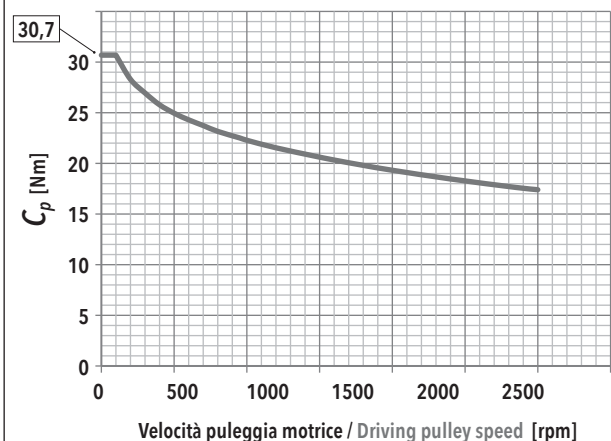

$F_{a,max}$ In funzione della velocità della puleggia motrice
Depending on the driving pulley rotational speed

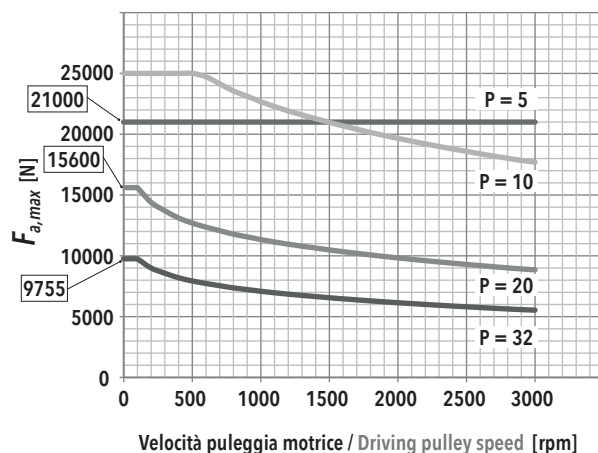

F_r Forza radiale su asse puleggia motrice in funzione di Cin
Radial force on driving pulley as a function of Cin

f_t Frequenza di vibrazione della cinghia per il tensionamento (al montaggio)
Vibration frequency of the belt for its tensioning (during assembly)

IE 100 - PASSO / PITCH 5					
F_a [N]		V_{out} [mm/s]			
		12,5	50	87,5	125
21000	F_r [N]	635	637	638	641
	f_t [Hz]	256	256	257	257
18900	F_r [N]	572	574	576	578
	f_t [Hz]	243	243	244	244
16800	F_r [N]	508	510	512	514
	f_t [Hz]	229	229	230	230
14700	F_r [N]	445	448	450	451
	f_t [Hz]	214	214	216	216
12600	F_r [N]	381	384	386	387
	f_t [Hz]	198	198	200	200
10500	F_r [N]	318	320	322	324
	f_t [Hz]	181	181	182	183
8400	F_r [N]	254	254	260	260
	f_t [Hz]	162	162	164	164
6300	F_r [N]	191	194	196	197
	f_t [Hz]	140	140	142	142
4200	F_r [N]	127	130	131	133
	f_t [Hz]	114	114	117	117
2100	F_r [N]	64	66	68	70
	f_t [Hz]	81	81	85	85

IE 100 - PASSO / PITCH 10					
F_a [N]		V_{out} [mm/s]			
		25	100	175	250
25000	F_r [N]	1512			
	f_t [Hz]	395			
22500	F_r [N]	1361	1362		
	f_t [Hz]	375	375		
20000	F_r [N]	1210	1211	1213	
	f_t [Hz]	353	353	354	
17500	F_r [N]	1059	1061	1063	1065
	f_t [Hz]	330	330	331	331
15000	F_r [N]	907	910	911	913
	f_t [Hz]	306	306	307	307
12500	F_r [N]	756	758	760	762
	f_t [Hz]	279	279	280	280
10000	F_r [N]	605	608	610	611
	f_t [Hz]	250	250	251	251
7500	F_r [N]	454	456	458	460
	f_t [Hz]	216	216	218	218
5000	F_r [N]	303	306	307	309
	f_t [Hz]	177	177	178	178
2500	F_r [N]	151	153	155	157
	f_t [Hz]	125	125	127	127

IE 100 - PASSO / PITCH 20					
F_a [N]		V_{out} [mm/s]			
		50	200	350	500
30000	F_r [N]				
	f_t [Hz]				
27000	F_r [N]				
	f_t [Hz]				
24000	F_r [N]				
	f_t [Hz]				
21000	F_r [N]				
	f_t [Hz]				
18000	F_r [N]				
	f_t [Hz]				
15000	F_r [N]				
	f_t [Hz]				
12000	F_r [N]	1452			
	f_t [Hz]	387			
9000	F_r [N]	1089	1090	1092	
	f_t [Hz]	335	335	336	
6000	F_r [N]	726	727	729	732
	f_t [Hz]	274	274	274	275
3000	F_r [N]	363	364	366	369
	f_t [Hz]	193	194	194	195

IE 100 - PASSO / PITCH 32					
F_a [N]		V_{out} [mm/s]			
		80	320	560	800
16000	F_r [N]				
	f_t [Hz]				
14400	F_r [N]				
	f_t [Hz]				
12800	F_r [N]				
	f_t [Hz]				
11200	F_r [N]				
	f_t [Hz]				
9600	F_r [N]				
	f_t [Hz]				
8000	F_r [N]		1549		
	f_t [Hz]		400		
6400	F_r [N]		1239	1240	
	f_t [Hz]		357	358	
4800	F_r [N]	929	930	932	935
	f_t [Hz]	310	310	310	311
3200	F_r [N]	619	620	622	626
	f_t [Hz]	253	253	253	254
1600	F_r [N]	310	311	313	316
	f_t [Hz]	179	179	180	180

3.7.6 Caratteristiche dimensionali

3.7.6 Overall dimensions

NOTA: Dati categorie motori / riduttori / rinvii al capitolo 4.

REMARK: Motors / Planetary / Angle bevel gearbox categories data at chapter 4.

B00
MODULO BASE
BASIC MODULE

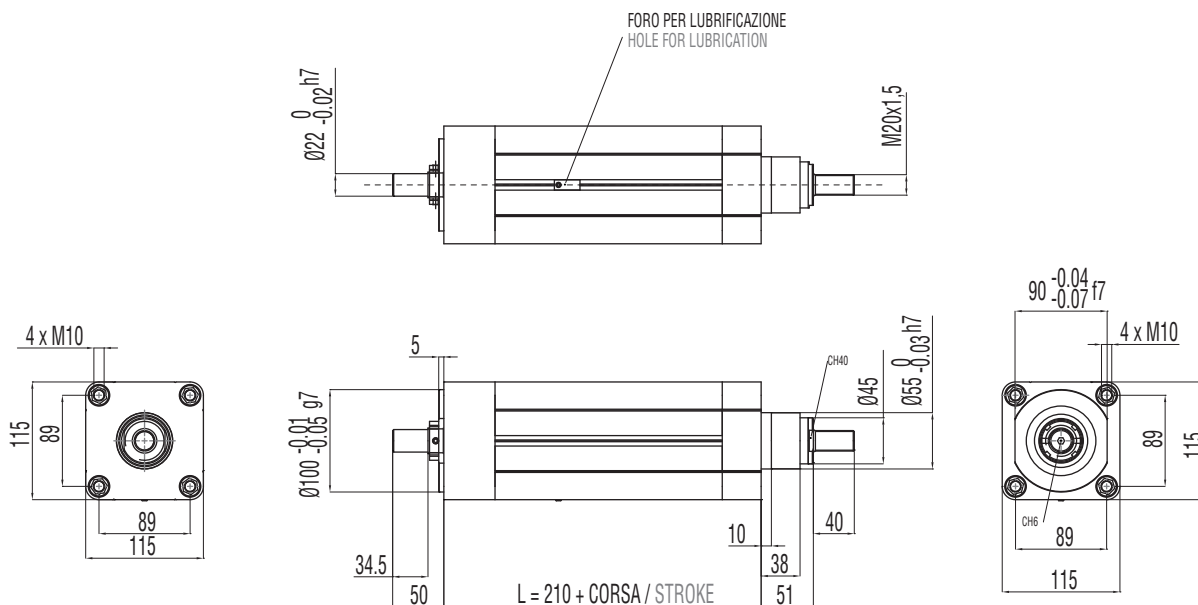
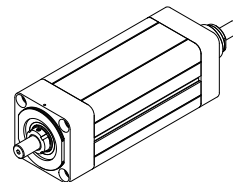

B00 + D00

MODULO BASE + TRASMISSIONE COASSIALE PER MOTORE CUSTOM
(SENZA RIDUTTORE)

**BASIC MODULE + CUSTOM IN-LINE TRANSMISSION W/O REDUCTION STAGE
FOR CUSTOM MOTORS**

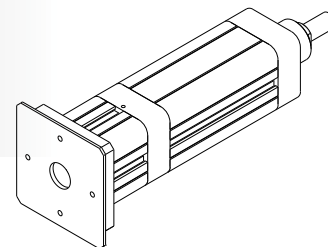

Cx C	DIMENSIONI LIMITI INTERFACCIA MAX INTERFACE DIMENSIONS			
	TAGLIA GIUNTO COUPLING SIZE	A [mm]	B [mm]	C [mm]
	150	30 max	40 min / 52 max	130 max

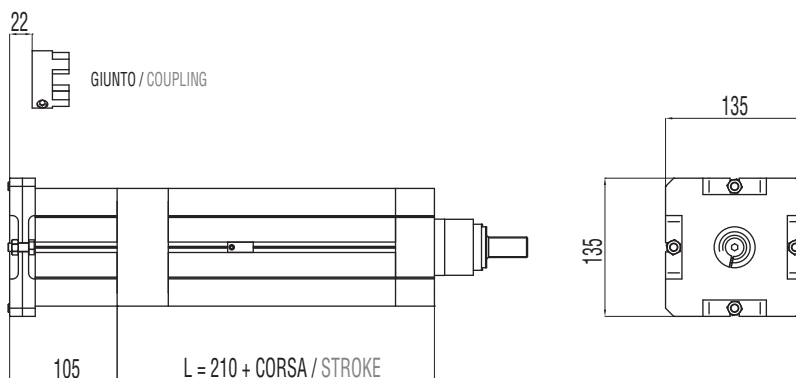

B00 + D01

MODULO BASE + TRASMISSIONE COASSIALE PER MOTORE COMPATIBILE
(SENZA RIDUTTORE)

**BASIC MODULE + IN-LINE TRANSMISSION W/O REDUCTION STAGE FOR
COMPATIBLE MOTORS**

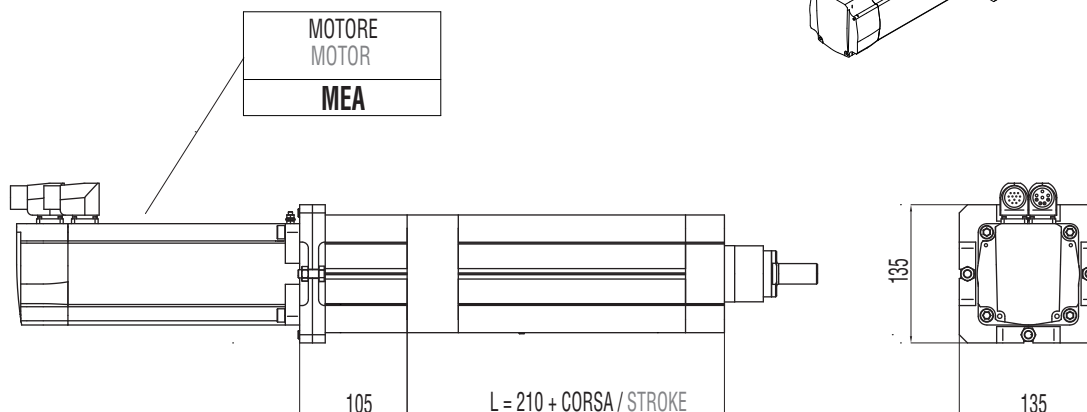
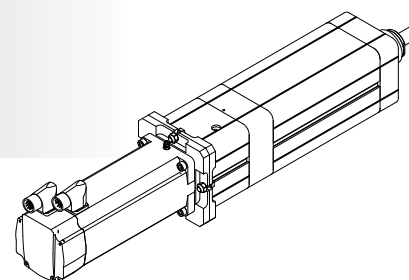

B00 + D02

MODULO BASE + RIDUTTORE EPICICLOIDALE COASSIALE COMPATIBILE

BASIC MODULE + IN-LINE COMPATIBLE PLANETARY GEARBOX REDUCTION STAGE

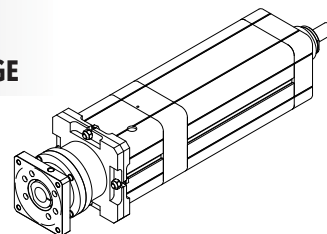

RIDUTTORE PLANETARY GEARBOX
GCA
GDA
GCB
GEB*

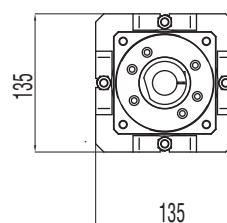
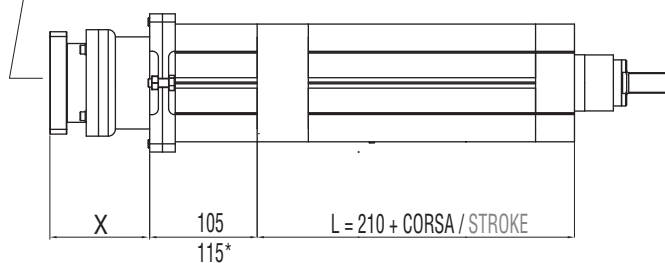

B00 + A01

MODULO BASE + RINVIO ANGOLARE COMPATIBILE

BASIC MODULE + COMPATIBLE ANGLE BEVEL GEARBOX STAGE

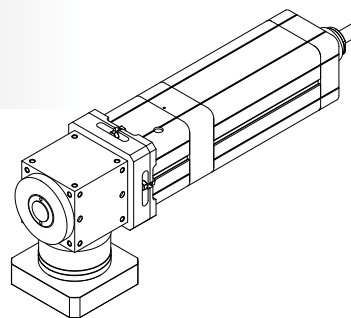

RINVIO ANGOLARE ANGLE BEVEL GEARBOX
ACA*
ADA**

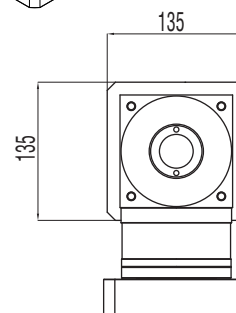
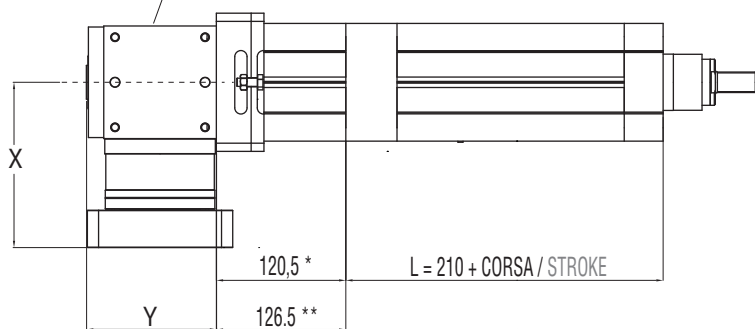

B00 + R00

MODULO BASE + TRASMISSIONE A CINGHIA IN PARALLELO PER MOTORE CUSTOM

BASIC MODULE + PARALLEL CUSTOM BELT GEARBOX STAGE FOR CUSTOM MOTORS

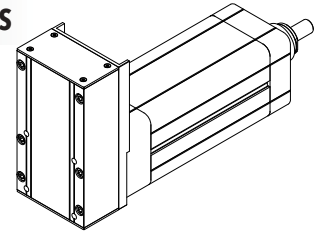

	DIMENSIONI LIMITI INTERFACCIA MAX INTERFACE DIMENSIONS		
	A [mm]	B [mm]	C [mm]
R=1:1	24 max	42 min / 58 max	110 max
R=1:2	19 max	36 min / 50 max	110 max

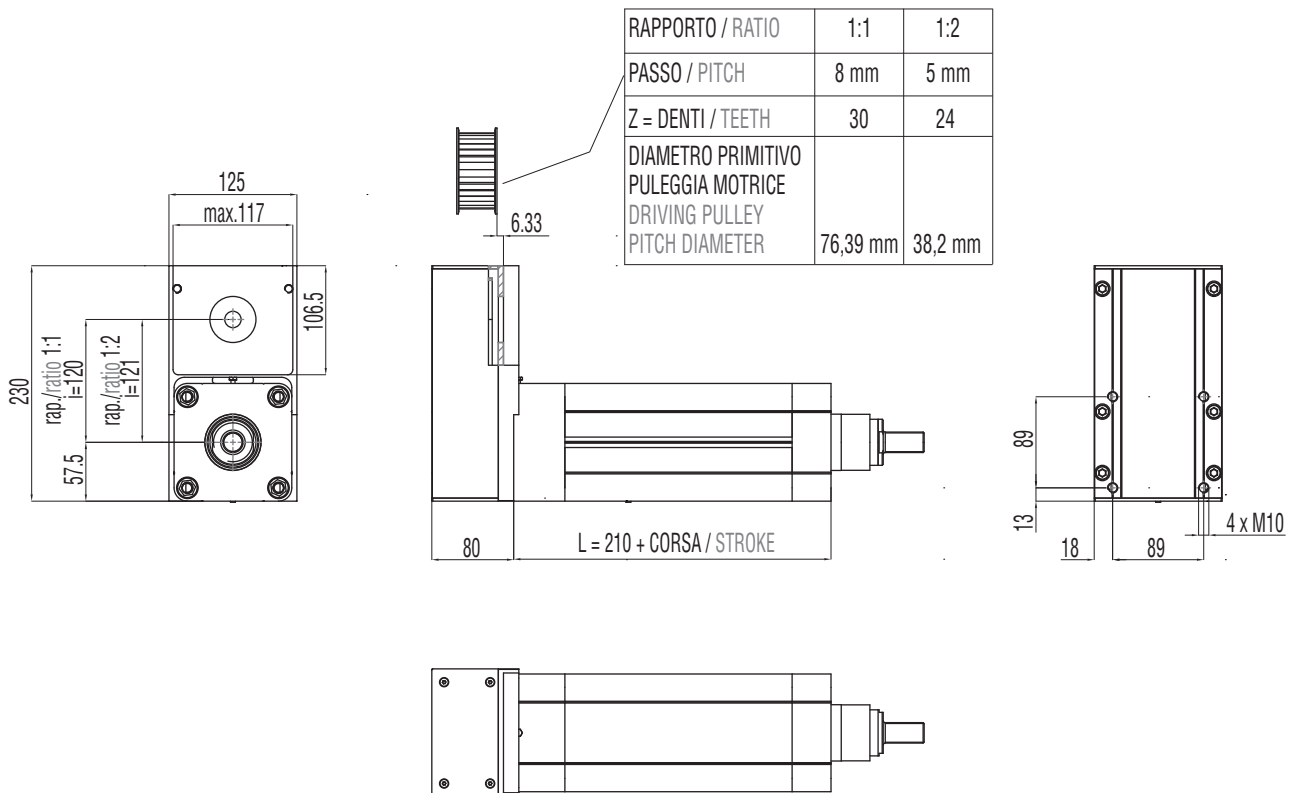

B00 + R01

MODULO BASE + TRASMISSIONE A CINGHIA IN PARALLELO PER MOTORE COMPATIBILE

BASIC MODULE + PARALLEL BELT GEARBOX STAGE FOR COMPATIBLE MOTORS

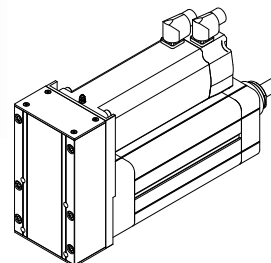

MOTORE MOTOR
MEA
MCA
MCB
MCC
MCD
MDA
MDB
MDC

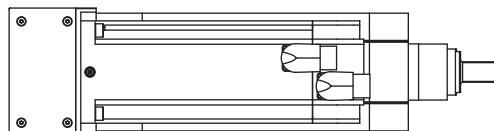
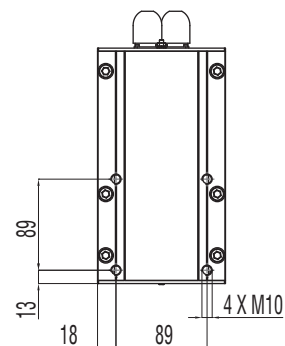
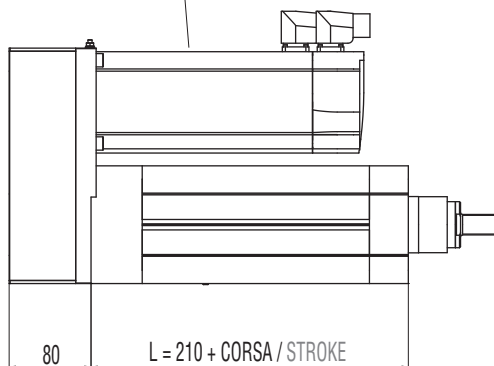
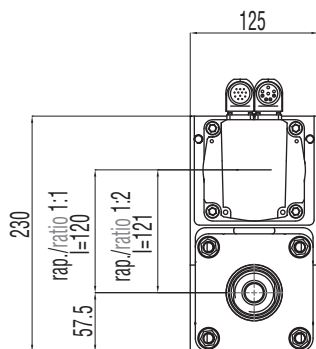

B00 + R02

MODULO BASE + TRASMISSIONE A CINGHIA IN PARALLELO +
RIDUTTORE EPICICLOIDALE COMPATIBILE

**BASIC MODULE + PARALLEL BELT GEARBOX STAGE +
IN-LINE COMPATIBLE PLANETARY GEARBOX REDUCTION STAGE**

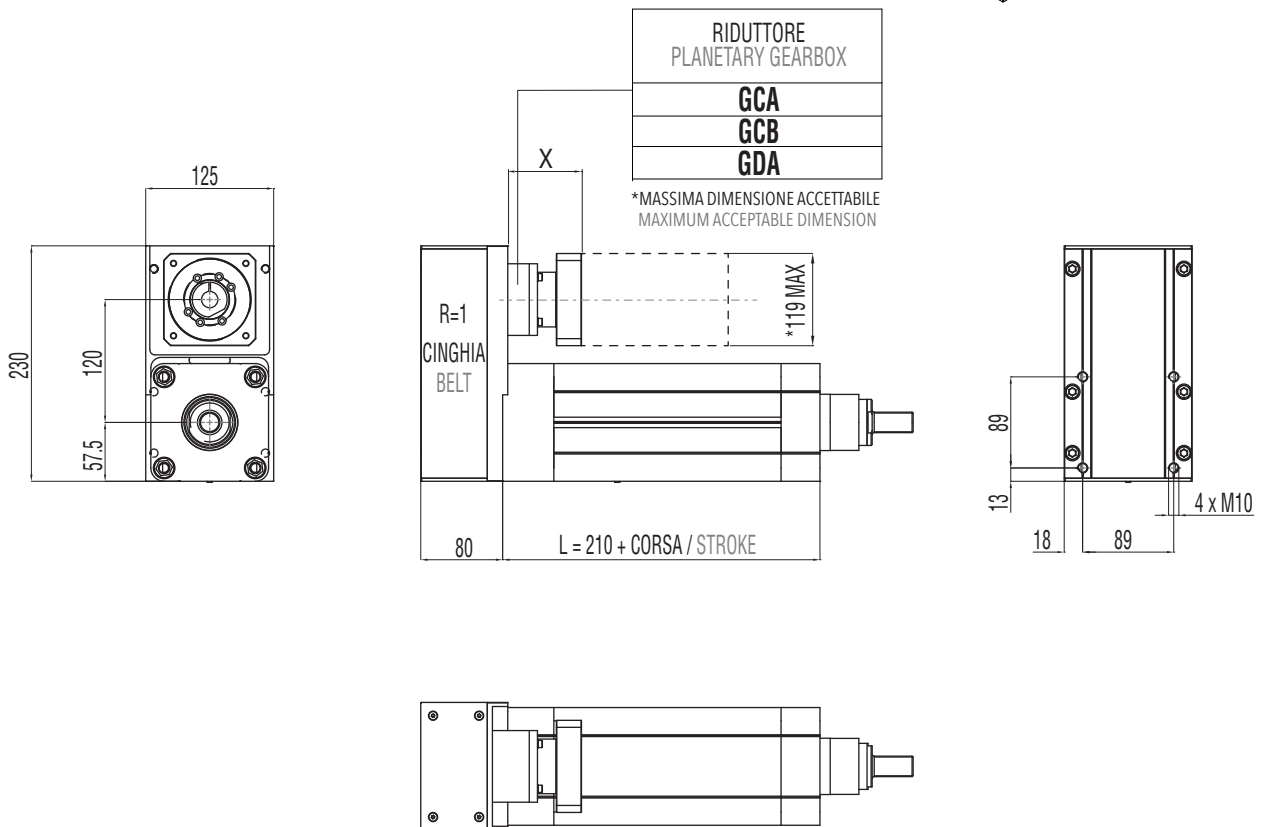
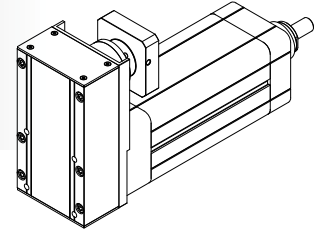

3.7.7 Accessori disponibili

Per le tabelle e i disegni tecnici degli accessori disponibili fare riferimento al paragrafo 3.10 (da pag. 136).

3.7.7 Available accessories

For tables and drawings please refer to paragraph 3.10 (from page 136).

3.8

IE 100 HL

3.8.1 Caratteristiche tecniche

3.8.1 Technical features

ISOMOVE IE 100 HL SENZA TIRANTI ISOMOVE IE 100 HL W/O TENSION RODS			5	10	20	40
P	PASSO VITE SCREW LEAD	[mm]	5	10	20	40
D	DIAMETRO VITE SCREW DIAMETER	[mm]	40	40	40	40
F_d	CARICO MASSIMO DINAMICO APPLICABILE MAX ADMISSIBLE DYNAMIC LOAD	[N]	23000*	30000*	30000*	30000*
C_{in,max}	PER AVERE $F_a = F_d$ TO GET	[Nm]	20,3	53	106	212
	"CASO 1" / "CASE 1": B00 + D00/D01	[Nm]	20,3	53	106	212
	"CASO 2" / "CASE 2": B00 + D02/A01	[Nm]	$\left[\frac{22,5}{R} \right] + C_s$	$\left[\frac{58,8}{R} \right] + C_s$	$\left[\frac{117,7}{R} \right] + C_s$	$\left[\frac{235,5}{R} \right] + C_s$
			R = rapporto di riduzione del riduttore / rinvio angolare R = planetary / angle bevel gearbox reduction ratio			
C_{m,max}	"CASO 3" / "CASE 3": B00 + R00/R01	[Nm]	$\frac{22,5}{R}$	$\frac{58,8}{R}$	$\frac{117,7}{R}$	$\frac{235,5}{R}$
			R = rapporto di riduzione della trasmissione a cinghia (disponibile R=1 oppure R=2) R = belt gearbox reduction ratio (available R=1 or R=2)			
	"CASO 4" / "CASE 4": B00 + R02	[Nm]	$\frac{25}{R}$	$\frac{65,3}{R}$	$\frac{130,7}{R}$	$\frac{261,6}{R}$
			R = rapporto di riduzione del riduttore epicicloidale R = planetary gearbox reduction ratio			
F_{st}	CARICO MASSIMO STATICO APPLICABILE MAX ADMISSIBLE STATIC LOAD	[N]	30000	30000	30000	30000
V_{out,max}	VELOCITÀ DI TRASLAZIONE MASSIMA IN USCITA / ROTAZIONE MASSIMA VITE RDS	[mm/sec]	208/2496	416/2496	833/2496	1660/2490
N_{in,max}	MAX OUTPUT SPEED / MAX BALLSCREW ROTATING INPUT SPEED	[rpm]				
a_{max}	ACCELERAZIONE MASSIMA IN USCITA MAX OUTPUT ACCELERATION	[m/sec ²]	1	2	3	6
S_{max}	CORSA MASSIMA STANDARD MAX STANDARD STROKE	[mm]	1100**	1100**	1100**	1100**
	PESO MODULO BASE CORSA 0 mm / PESO OGNI 100 mm DI CORSA BASIC MODULE WEIGHT FOR 0 mm STROKE / WEIGHT FOR ADDITIONAL 100 mm STROKE	[Kg]	9,3 / 2,9	9,3 / 2,9	9,3 / 2,9	9,3 / 2,9
G_{s,max}	GIOCO ASSIALE MASSIMO PER CHIOCCIOLA STANDARD MAX AXIAL BACKLASH FOR STANDARD BALLSCREW ASSEMBLY	mm	0,06	0,06	0,06	0,06
G_z	GIOCO "0" DELLA CHIOCCIOLA "0" BACKLASH BALLSCREW ASSEMBLY		DISPONIBILE / AVAILABLE			
L_{10,Km}	DURATA LIFETIME	Km	VEDI TABELLA / SEE TABLE pg. 114			























* Per le versioni R00/R01 controllare con i grafici delle pagine 116/117. / For R00/R01 types please check graph at pages 116/117.

** Per corse superiori, contattare il nostro servizio tecnico. / For longer strokes please contact our technical dept.

ISOMOVE IE 100 HL SENZA TIRANTI ISOMOVE IE 100 HL W/O TENSION RODS		5	10	20	40
VERSIONI DISPONIBILI AVAILABLE TYPES		D00 / D01 / D02 / R00 / R01 / R02 / A01			
F_{a,p}	POSSIBILE CON IL RIDUTTORE EPICICLOIDALE INDICATO POSSIBLE VALUE WITH THE INDICATED PLANETARY GEARBOX [N]	AE070/23000 AE090/23000 AE120/23000 PGII-080/23000 PGII-120/23000	AE070/21750*** AE090/30000 AE120/30000 PGII-080/28000*** PGII-120/30000	AE070/8800*** AE090/21900*** AE120/30000 PGII-080/14300*** PGII-120/30000	AE070/4400*** AE090/11000*** AE120/23000*** PGII-080/7150*** PGII-120/16500
	POSSIBILE CON IL RINVIO ANGOLARE INDICATO POSSIBLE VALUE WITH THE INDICATED ANGLE BEVEL GEARBOX [N]	ATB090/23000 ATB110/23000 ATB140/23000	ATB090/18650*** ATB110/30000 ATB140/30000	ATB090/9350*** ATB110/18630*** ATB140/20000***	ATB090/4390*** ATB110/18630*** ATB140/21540***
ACCESSORI DISPONIBILI AVAILABLE ACCESSORIES		VEDI PARAGRAFO / SEE PARAGRAPH 3.10 (pg. 136)			

*** È il valore massimo ottenibile con il rapporto di riduzione disponibile avente il minore valore di coppia erogabile.
It is the max obtainable value with the available on tables reduction ratio which has the lowest value of nominal output torque.

RIDUTTORI-RINVII "STANDARD SETEC GROUP DISPONIBILI"
"STANDARD SETEC GROUP AVAILABLE" PLANETARY-ANGLE BEVEL GEARBOXES

<p>TRASMISSIONE COASSIALE CON RIDUTTORE IN-LINE PLANETARY GEARBOX STAGE</p>	 AE070	 MODULO BASE BASIC MODULE	 AE090	 MODULO BASE BASIC MODULE	 AE120	 MODULO BASE BASIC MODULE
		 PGII-080	 MODULO BASE BASIC MODULE	 PGII-120	 MODULO BASE BASIC MODULE	
<p>TRASMISSIONE PARALLELA CON RIDUTTORE PARALLEL BELT GEARBOX STAGE + IN-LINE PLANETARY GEARBOX REDUCTION STAGE</p>	 AE070	 MODULO BASE BASIC MODULE	 AE090	 MODULO BASE BASIC MODULE	 PGII-080	 MODULO BASE BASIC MODULE
<p>TRASMISSIONE ANGOLARE CON RINVIO ANGLE BEVEL GEARBOX STAGE</p>	 ATB090	 MODULO BASE BASIC MODULE	 ATB110	 MODULO BASE BASIC MODULE	 ATB140	 MODULO BASE BASIC MODULE

ISOMOVE IE 100 HL CON TIRANTI ISOMOVE IE 100 HL WITH TENSION RODS		5	10	20	40
P	PASSO VITE SCREW LEAD [mm]	5	10	20	40
D	DIAMETRO VITE SCREW DIAMETER [mm]	40	40	40	40
F_d	CARICO MASSIMO DINAMICO APPLICABILE MAX ADMISSIBLE DYNAMIC LOAD [N]	23000*	41000*	40000*	40000*
C_{in,max}	PER AVERE $F_a = F_d$ TO GET [Nm]	20,3	72,5	142	283
	"CASO 1" / "CASE 1": B00 + D00/D01 [Nm]	20,3	72,5	142	283
	"CASO 2" / "CASE 2": B00 + D02/A01 [Nm]	$\left[\frac{22,5}{R} \right] + C_s$	$\left[\frac{80,5}{R} \right] + C_s$	$\left[\frac{117,7}{R} \right] + C_s$	$\left[\frac{235,5}{R} \right] + C_s$
		R = rapporto di riduzione del riduttore / rinvio angolare R = planetary / angle bevel gearbox reduction ratio			
C_{m,max}	"CASO 3" / "CASE 3": B00 + R00/R01 [Nm]	$\frac{22,5}{R}$	$\frac{80,5}{R}$	$\frac{117,7}{R}$	$\frac{235,5}{R}$
		R = rapporto di riduzione della trasmissione a cinghia (disponibile R=1 oppure R=2) R = belt gearbox reduction ratio (available R=1 or R=2)			
	"CASO 4" / "CASE 4": B00 + R02 [Nm]	$\frac{25}{R}$	$\frac{89}{R}$	$\frac{130,7}{R}$	$\frac{261,6}{R}$
		R = rapporto di riduzione del riduttore epicicloidale R = planetary gearbox reduction ratio			
F_{st}	CARICO MASSIMO STATICO APPLICABILE MAX ADMISSIBLE STATIC LOAD [N]	41000	41000	40000	40000
V_{out,max}	VELOCITÀ DI TRASLAZIONE MASSIMA IN USCITA / ROTAZIONE MASSIMA VITE RDS [mm/sec]	208/2496	416/2496	833/2496	1660/2490
N_{in,max}	MAX OUTPUT SPEED / MAX BALLSCREW ROTATING INPUT SPEED [rpm]				
a_{max}	ACCELERAZIONE MASSIMA IN USCITA MAX OUTPUT ACCELERATION [m/sec ²]	1	2	3	6
S_{max}	CORSA MASSIMA STANDARD MAX STANDARD STROKE [mm]	1100**	1100**	1100**	1100**
	PESO MODULO BASE CORSA 0 mm / PESO OGNI 100 mm DI CORSA [Kg] BASIC MODULE WEIGHT FOR 0 mm STROKE / WEIGHT FOR ADDITIONAL 100 mm STROKE	9,6 / 4,2	9,6 / 4,2	9,6 / 4,2	9,6 / 4,2
G_{s,max}	GIOCO ASSIALE MASSIMO PER CHIOCCIOLA STANDARD MAX AXIAL BACKLASH FOR STANDARD BALLSCREW ASSEMBLY mm	0,06	0,06	0,06	0,06
G_z	GIOCO "0" DELLA CHIOCCIOLA "0" BACKLASH BALLSCREW ASSEMBLY	DISPONIBILE / AVAILABLE			
L_{10,Km}	DURATA LIFETIME Km	VEDI TABELLA / SEE TABLE pg. 114			









* Per le versioni R00/R01 controllare con i grafici delle pagine 116/117. / For R00/R01 types please check graph at pages 116/117.

** Per corse superiori, contattare il nostro servizio tecnico. / For longer strokes please contact our technical dpt.

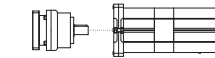
ISOMOVE IE 100 HL CON TIRANTI ISOMOVE IE 100 HL WITH TENSION RODS		5	10	20	40
VERSIONI DISPONIBILI AVAILABLE TYPES		D00 / D01 / D02 / R00 / R01 / R02 / A01			
F_{a,p}	POSSIBILE CON IL RIDUTTORE EPICICLOIDALE INDICATO POSSIBLE VALUE WITH THE INDICATED PLANETARY GEARBOX [N]	AE070/23000 AE090/23000 AE120/23000 PGII-080/23000 PGII-120/23000	AE070/21750*** AE090/30000 AE120/30000 PGII-080/28000*** PGII-120/30000	AE070/8800*** AE090/21900*** AE120/30000 PGII-080/14300*** PGII-120/30000	AE070/4400*** AE090/11000*** AE120/23000*** PGII-080/7150*** PGII-120/16500
	POSSIBILE CON IL RINVIO ANGOLARE INDICATO POSSIBLE VALUE WITH THE INDICATED ANGLE BEVEL GEARBOX [N]	ATB090/23000 ATB110/23000 ATB140/23000	ATB090/18650*** ATB110/30000 ATB140/30000	ATB090/9350*** ATB110/18630*** ATB140/20000***	ATB090/4390*** ATB110/18630*** ATB140/21540***
ACCESSORI DISPONIBILI AVAILABLE ACCESSORIES		VEDI PARAGRAFO / SEE PARAGRAPH 3.10 (pg. 134)			

*** È il valore massimo ottenibile con il rapporto di riduzione disponibile avente il minore valore di coppia erogabile.
It is the max obtainable value with the available on tables reduction ratio which has the lowest value of nominal output torque.

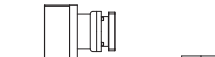
RIDUTTORI-RINVII "STANDARD SETEC GROUP DISPONIBILI"
"STANDARD SETEC GROUP AVAILABLE" PLANETARY-ANGLE BEVEL GEARBOXES

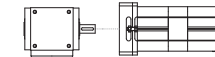
TRASMISSIONE COASSIALE CON RIDUTTORE IN-LINE PLANETARY GEARBOX STAGE	 AE070	 AE090	 AE120	 PGII-080	 PGII-120
	MODULO BASE BASIC MODULE	MODULO BASE BASIC MODULE	MODULO BASE BASIC MODULE	MODULO BASE BASIC MODULE	MODULO BASE BASIC MODULE
TRASMISSIONE PARALLELA CON RIDUTTORE PARALLEL BELT GEARBOX STAGE + IN-LINE PLANETARY GEARBOX REDUCTION STAGE	 AE070	 AE090	 PGII-080		
	MODULO BASE BASIC MODULE	MODULO BASE BASIC MODULE	MODULO BASE BASIC MODULE		
TRASMISSIONE ANGOLARE CON RINVIO ANGLE BEVEL GEARBOX STAGE	 ATB090	 ATB110	 ATB140		
	MODULO BASE BASIC MODULE	MODULO BASE BASIC MODULE	MODULO BASE BASIC MODULE		

3.8.2 Calcolo durata

3.8.2 Lifetime calculation

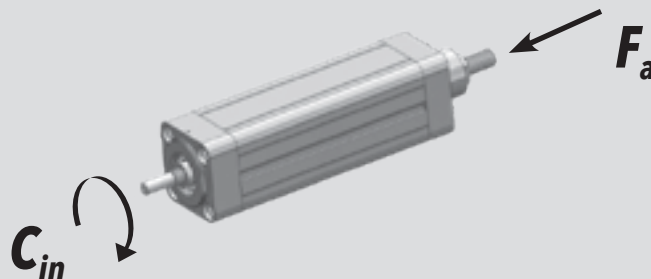

IE 100 HL P = 5 mm	$L_{10,Km} = \left[\frac{25900}{F_{eq}} \right]^3 \cdot 5$	$L_{10,Km} = [Km]$ $F_{eq} = [N]$
IE 100 HL P = 10 mm	$L_{10,Km} = \left[\frac{59200}{F_{eq}} \right]^3 \cdot 10$	$L_{10,Km} = [Km]$ $F_{eq} = [N]$
IE 100 HL P = 20 mm	$L_{10,Km} = \left[\frac{59200}{F_{eq}} \right]^3 \cdot 20$	$L_{10,Km} = [Km]$ $F_{eq} = [N]$
IE 100 HL P = 40 mm	$L_{10,Km} = \left[\frac{59200}{F_{eq}} \right]^3 \cdot 40$	$L_{10,Km} = [Km]$ $F_{eq} = [N]$

3.8.3 Calcolo coppia in ingresso
al modulo base3.8.3 Torque calculation at basic
module input shaft

IE 100 HL P = 5 mm	$C_{in} = \left[\frac{F_a \cdot 5}{5652} \right]$	$C_{in} = [Nm]$ $F_a = [N]$
IE 100 HL P = 10 mm	$C_{in} = \left[\frac{F_a \cdot 10}{5652} \right]$	$C_{in} = [Nm]$ $F_a = [N]$
IE 100 HL P = 20 mm	$C_{in} = \left[\frac{F_a \cdot 20}{5652} \right]$	$C_{in} = [Nm]$ $F_a = [N]$
IE 100 HL P = 40 mm	$C_{in} = \left[\frac{F_a \cdot 40}{5652} \right]$	$C_{in} = [Nm]$ $F_a = [N]$

3.8.4 Calcolo coppia motore

3.8.4 Motor torque calculation

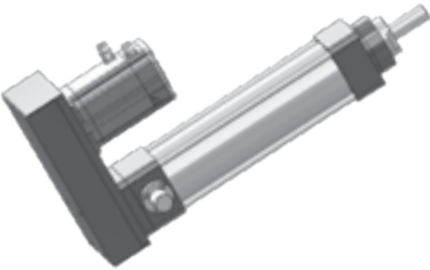
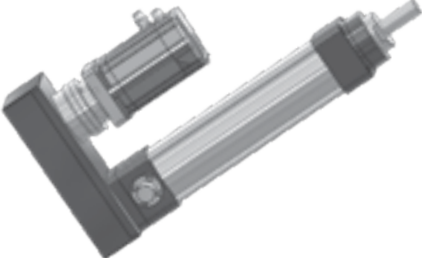
<p>CASO / CASE</p> <p>1</p>	<p>ISOMOVE B00 + D00 / D01</p>  $C_m = C_{in} \quad [Nm]$
<p>CASO / CASE</p> <p>2</p>	<p>ISOMOVE B00 + D02 / A01</p>  $C_m = \left[\frac{C_{in}}{R \cdot \eta} \right] + C_s \quad [Nm]$ <p><i>R</i> = rapporto di riduzione riduttore / rinvio planetary / angle bevel gearbox reduction ratio <i>η</i> = rendimento meccanico / mechanical efficiency = 0,90</p>
<p>CASO / CASE</p> <p>3</p>	<p>ISOMOVE B00 + R00 / R01</p>  $C_m = \left[\frac{C_{in}}{R \cdot \eta} \right] \quad [Nm]$ <p><i>R</i> = rapporto di riduzione trasmissione a cinghia, disponibile R=1 o R=2 belt gearbox reduction ratio, available R=1 or R=2 <i>η</i> = rendimento meccanico / mechanical efficiency = 0,90</p>
<p>CASO / CASE</p> <p>4</p>	<p>ISOMOVE B00 + R02</p>  $C_m = \left[\frac{C_{in}}{R \cdot \eta} \right] + C_s \quad [Nm]$ <p><i>R</i> = rapporto di riduzione riduttore epicicloidale planetary gearbox reduction ratio <i>η</i> = rendimento meccanico / mechanical efficiency = 0,81</p>

3.8.5 Potenza in ingresso alla trasmissione a cinghia (versione R)

3.8.5 Mechanical input power at belt gear stage (R type)

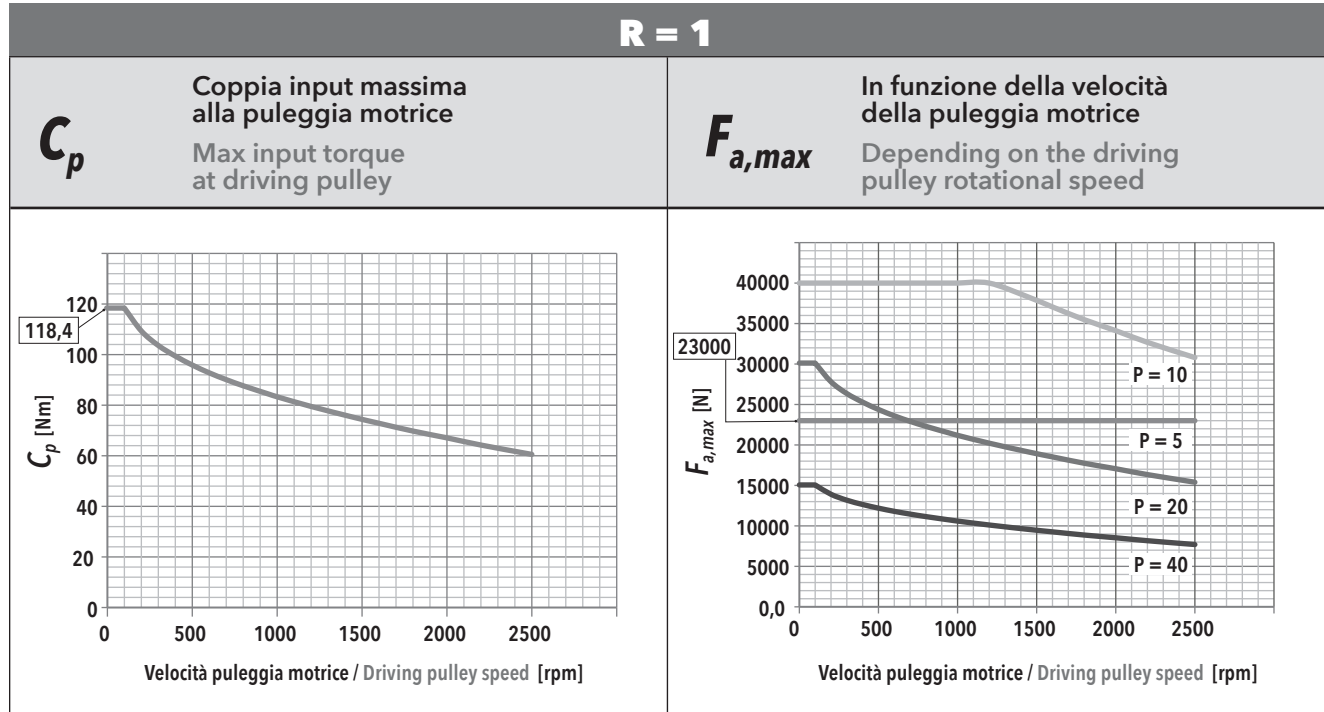

F_r Forza radiale su asse puleggia motrice in funzione di C_{in}
Radial force on driving pulley as a function of C_{in}

f_t Frequenza di vibrazione della cinghia per il tensionamento (al montaggio)
Vibration frequency of the belt for its tensioning (during assembly)

IE 100 HL - PASSO / PITCH 5						IE 100 HL - PASSO / PITCH 10						IE 100 HL - PASSO / PITCH 20						IE 100 HL - PASSO / PITCH 40					
F_a [N]		V_{out} [mm/s]				F_a [N]		V_{out} [mm/s]				F_a [N]		V_{out} [mm/s]				F_a [N]		V_{out} [mm/s]			
		20,8	83,2	145,6	208			41,6	166,4	291,2	416			83	333	583	833			166	664	1162	1660
23000	F_r [N]	675	679	687	700	41000	F_r [N]	2406	2410			40000	F_r [N]					40000	F_r [N]				
	f_t [Hz]	217	218	219	221		f_t [Hz]	410	410				f_t [Hz]							f_t [Hz]			
20700	F_r [N]	608	611	619	632	36900	F_r [N]	2165	2169	2177		36000	F_r [N]					36000	F_r [N]				
	f_t [Hz]	206	206	208	210		f_t [Hz]	389	389	390			f_t [Hz]							f_t [Hz]			
18400	F_r [N]	540	544	552	565	32800	F_r [N]	1925	1929	1937	1949	32000	F_r [N]					32000	F_r [N]				
	f_t [Hz]	194	195	196	198		f_t [Hz]	366	367	367	369		f_t [Hz]							f_t [Hz]			
16100	F_r [N]	473	476	485	497	28700	F_r [N]	1684	1688	1696	1709	28000	F_r [N]					28000	F_r [N]				
	f_t [Hz]	182	182	184	186		f_t [Hz]	343	343	344	345		f_t [Hz]							f_t [Hz]			
13800	F_r [N]	405	409	417	430	24600	F_r [N]	1444	1447	1456	1468	24000	F_r [N]	2817				24000	F_r [N]				
	f_t [Hz]	168	169	171	173		f_t [Hz]	317	318	319	320		f_t [Hz]	443						f_t [Hz]			
11500	F_r [N]	338	341	350	362	20500	F_r [N]	1203	1207	1215	1228	20000	F_r [N]	2347	2351			20000	F_r [N]				
	f_t [Hz]	153	154	156	159		f_t [Hz]	290	290	291	293		f_t [Hz]	405	405					f_t [Hz]			
9200	F_r [N]	270	274	282	295	16400	F_r [N]	963	966	974	987	16000	F_r [N]	1878	1882	1890		16000	F_r [N]				
	f_t [Hz]	137	138	140	143		f_t [Hz]	259	260	261	262		f_t [Hz]	362	362	363				f_t [Hz]			
6900	F_r [N]	203	206	215	227	12300	F_r [N]	722	726	734	747	12000	F_r [N]	1408	1412	1420	1433	12000	F_r [N]	2817			
	f_t [Hz]	119	120	122	126		f_t [Hz]	224	225	226	228		f_t [Hz]	313	314	315	316		f_t [Hz]	443			
4600	F_r [N]	135	139	147	160	8200	F_r [N]	481	485	493	506	8000	F_r [N]	939	943	951	964	8000	F_r [N]	1878	1882	1890	
	f_t [Hz]	97	98	101	106		f_t [Hz]	183	184	185	188		f_t [Hz]	256	256	257	259		f_t [Hz]	362	362	363	
2300	F_r [N]	68	71	80	92	4100	F_r [N]	241	245	253	265	4000	F_r [N]	470	473	482	494	4000	F_r [N]	939	943	951	964
	f_t [Hz]	69	71	75	80		f_t [Hz]	130	131	133	136		f_t [Hz]	181	182	183	186		f_t [Hz]	256	256	257	259

R = 2

C_p Coppia input massima alla puleggia motrice
Max input torque at driving pulley

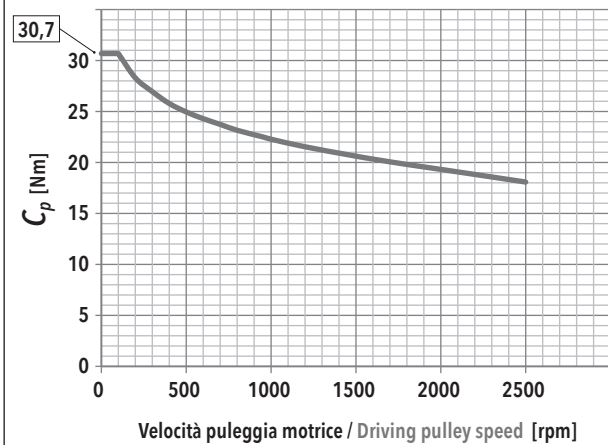

$F_{a,max}$ In funzione della velocità della puleggia motrice
Depending on the driving pulley rotational speed

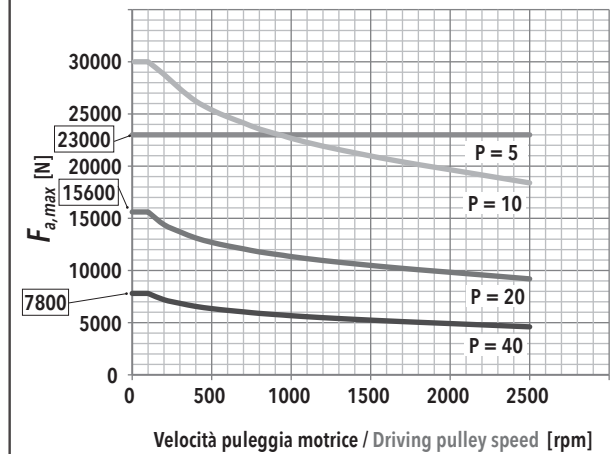

F_r Forza radiale su asse puleggia motrice in funzione di Cin
Radial force on driving pulley as a function of Cin

f_t Frequenza di vibrazione della cinghia per il tensionamento (al montaggio)
Vibration frequency of the belt for its tensioning (during assembly)

IE 100 HL - PASSO / PITCH 5					
F_a [N]		V_{out} [mm/s]			
		10,4	41,6	72,8	104
23000	F_r [N]	696	696	700	700
	f_t [Hz]	268	268	269	269
20700	F_r [N]	626	626	630	630
	f_t [Hz]	254	254	255	255
18400	F_r [N]	557	557	561	561
	f_t [Hz]	240	240	240	240
16100	F_r [N]	487	487	491	491
	f_t [Hz]	224	224	225	225
13800	F_r [N]	417	417	422	422
	f_t [Hz]	207	207	208	208
11500	F_r [N]	348	348	352	352
	f_t [Hz]	189	189	191	191
9200	F_r [N]	278	278	282	282
	f_t [Hz]	169	169	171	171
6900	F_r [N]	209	209	213	213
	f_t [Hz]	147	147	148	148
4600	F_r [N]	139	139	143	143
	f_t [Hz]	120	120	122	122
2300	F_r [N]	70	70	74	74
	f_t [Hz]	85	85	87	87

IE 100 HL - PASSO / PITCH 10					
F_a [N]		V_{out} [mm/s]			
		20,8	83,2	145,6	208
41000	F_r [N]				
	f_t [Hz]				
36900	F_r [N]				
	f_t [Hz]				
32800	F_r [N]				
	f_t [Hz]				
28700	F_r [N]				
	f_t [Hz]				
24600	F_r [N]	1488			
	f_t [Hz]	392			
20500	F_r [N]	1240	1241	1242	
	f_t [Hz]	358	358	358	
16400	F_r [N]	992	993	994	996
	f_t [Hz]	320	320	320	320
12300	F_r [N]	744	744	748	748
	f_t [Hz]	277	277	278	278
8200	F_r [N]	496	496	500	500
	f_t [Hz]	226	227	227	227
4100	F_r [N]	248	248	252	252
	f_t [Hz]	160	160	161	161

IE 100 HL - PASSO / PITCH 20					
F_a [N]		V_{out} [mm/s]			
		41	166	291	416
40000	F_r [N]				
	f_t [Hz]				
36000	F_r [N]				
	f_t [Hz]				
32000	F_r [N]				
	f_t [Hz]				
28000	F_r [N]				
	f_t [Hz]				
24000	F_r [N]				
	f_t [Hz]				
20000	F_r [N]				
	f_t [Hz]				
16000	F_r [N]				
	f_t [Hz]				
12000	F_r [N]	1452			
	f_t [Hz]	387			
8000	F_r [N]	968	969	970	
	f_t [Hz]	316	316	316	
4000	F_r [N]	484	485	486	488
	f_t [Hz]	223	224	224	224

IE 100 HL - PASSO / PITCH 40					
F_a [N]		V_{out} [mm/s]			
		83	332	581	830
40000	F_r [N]				
	f_t [Hz]				
36000	F_r [N]				
	f_t [Hz]				
32000	F_r [N]				
	f_t [Hz]				
28000	F_r [N]				
	f_t [Hz]				
24000	F_r [N]				
	f_t [Hz]				
20000	F_r [N]				
	f_t [Hz]				
16000	F_r [N]				
	f_t [Hz]				
12000	F_r [N]				
	f_t [Hz]				
8000	F_r [N]				
	f_t [Hz]				
4000	F_r [N]	968	969	970	972
	f_t [Hz]	316	316	316	317

3.8.6 Caratteristiche dimensionali

3.8.6 Overall dimensions

NOTA: Dati categorie motori / riduttori / rinvii al capitolo 4.

REMARK: Motors / Planetary / Angle bevel gearbox categories data at chapter 4.

B00
MODULO BASE
BASIC MODULE

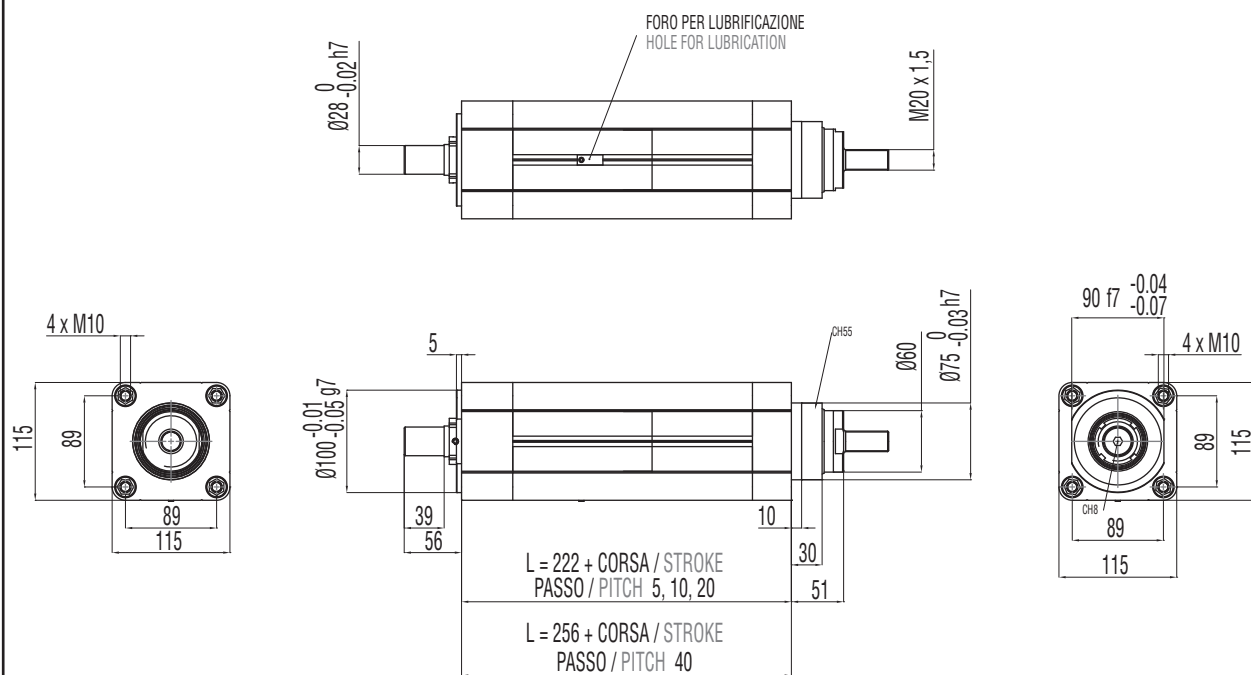
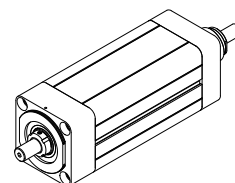

B00 + D00

MODULO BASE + TRASMISSIONE COASSIALE PER MOTORE CUSTOM
(SENZA RIDUTTORE)

BASIC MODULE + CUSTOM IN-LINE TRANSMISSION W/O REDUCTION STAGE
FOR CUSTOM MOTORS

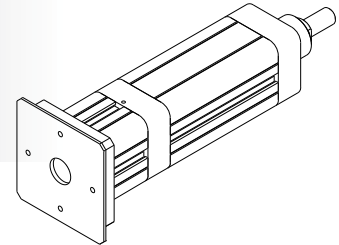

CxC	DIMENSIONI LIMITI INTERFACCIA MAX INTERFACE DIMENSIONS			
	TAGLIA GIUNTO COUPLING SIZE	A [mm]	B [mm]	C [mm]
	150	30 max	40 min / 52 max	130 max

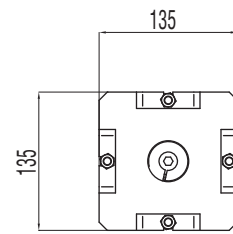
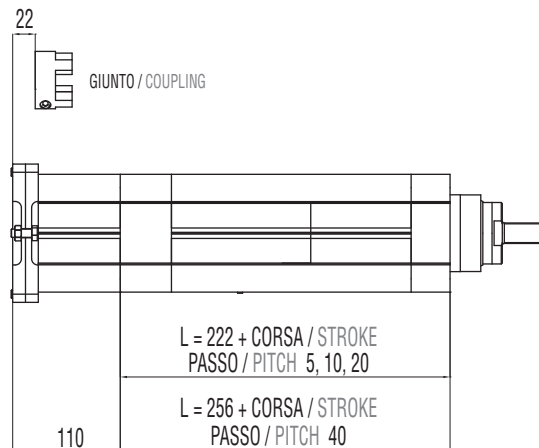

B00 + D01

MODULO BASE + TRASMISSIONE COASSIALE PER MOTORE COMPATIBILE
(SENZA RIDUTTORE)

BASIC MODULE + IN-LINE TRANSMISSION W/O REDUCTION STAGE FOR
COMPATIBLE MOTORS

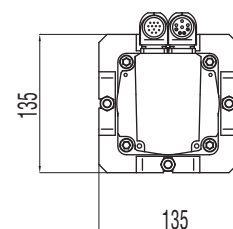
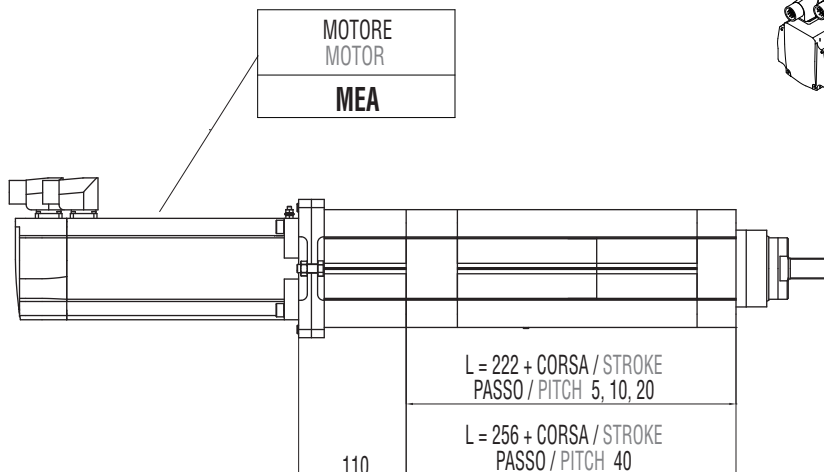
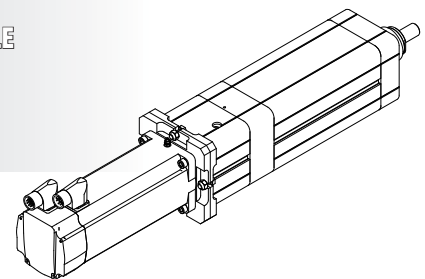

B00 + D02

MODULO BASE + RIDUTTORE EPICICLOIDALE COASSIALE COMPATIBILE

BASIC MODULE + IN-LINE COMPATIBLE PLANETARY GEARBOX REDUCTION STAGE

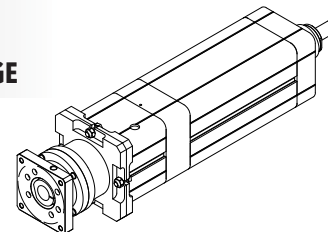

RIDUTTORE / PLANETARY GEARBOX
GCA*
GDA**
GEA***
GCB*
GEB**

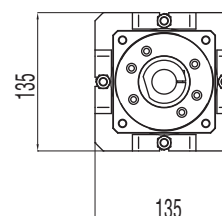
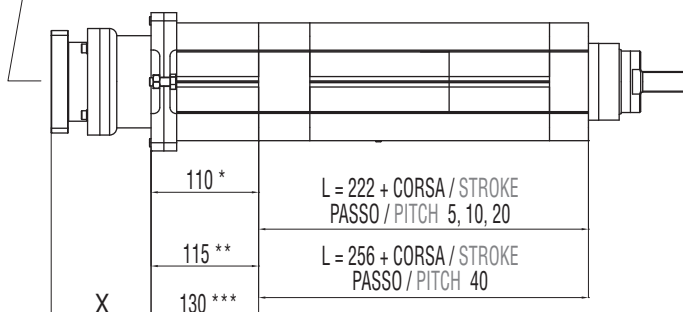

B00 + A01

MODULO BASE + RINVIO ANGOLARE COMPATIBILE

BASIC MODULE + COMPATIBLE ANGLE BEVEL GEARBOX STAGE

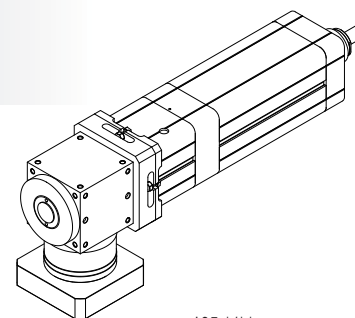

RINVIO ANGOLARE ANGLE BEVEL GEARBOX
ACA*
ADA**
AEA***

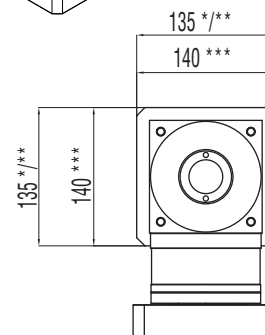
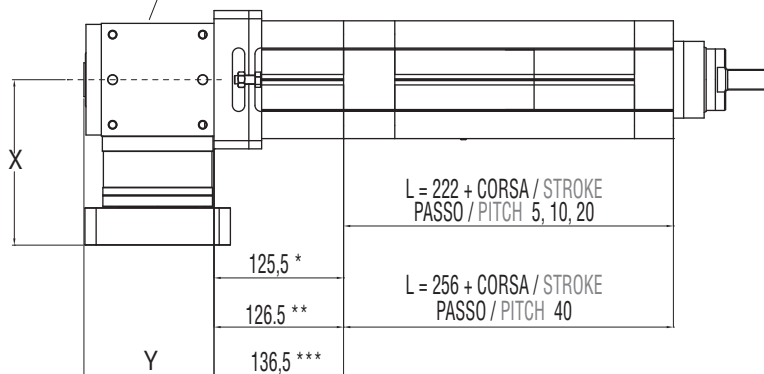

B00 + R00

MODULO BASE + TRASMISSIONE A CINGHIA IN PARALLELO PER MOTORE CUSTOM

BASIC MODULE + PARALLEL CUSTOM BELT GEARBOX STAGE FOR CUSTOM MOTORS

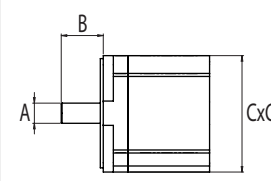

DIMENSIONI LIMITI INTERFACCIA MAX INTERFACE DIMENSIONS			
	A	B	C
	[mm]	[mm]	[mm]
R=1:1	24 max	42 min / 58 max	110 max
R=1:2	19 max	36 min / 50 max	110 max

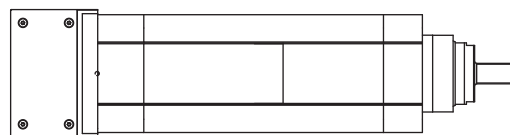
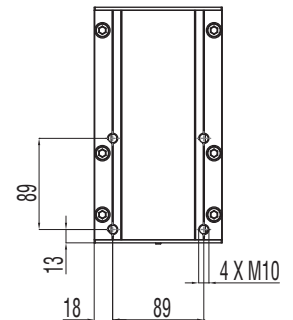
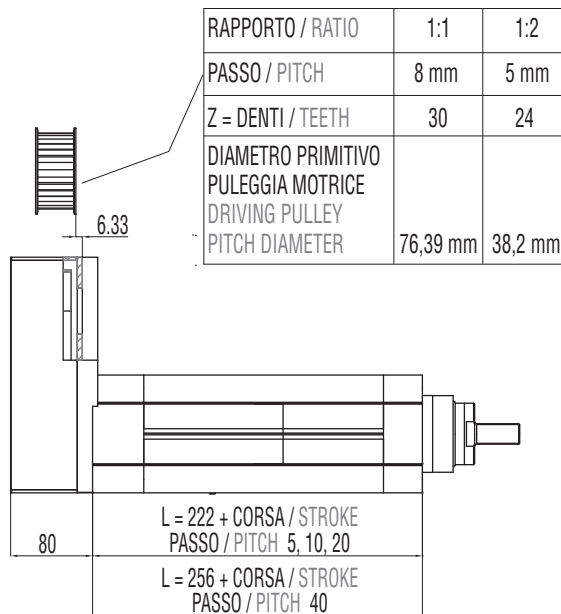
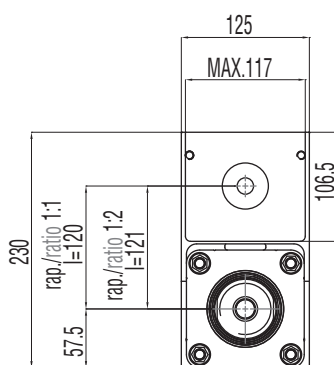
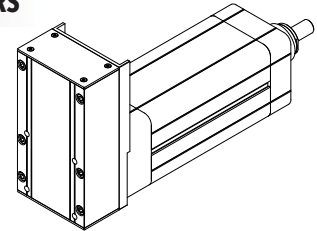

B00 + R01

MODULO BASE + TRASMISSIONE A CINGHIA IN PARALLELO PER MOTORE COMPATIBILE

BASIC MODULE + PARALLEL BELT GEARBOX STAGE FOR COMPATIBLE MOTORS

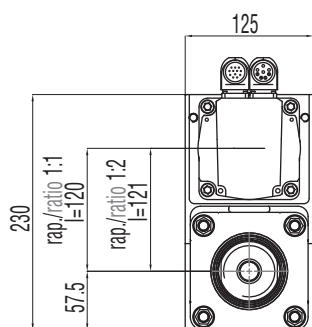
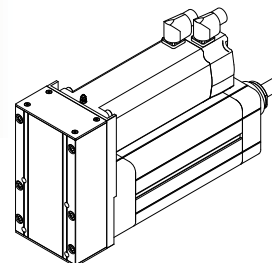

MOTORE MOTOR
MEA
MCA
MCB
MCC
MCD
MDA
MDB
MDC

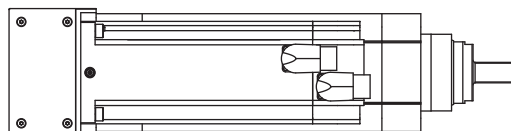
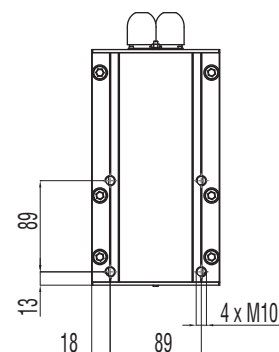
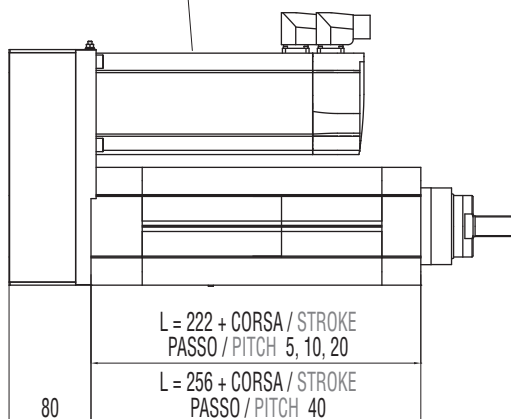

B00 + R02

MODULO BASE + TRASMISSIONE A CINGHIA IN PARALLELO +
RIDUTTORE EPICICLOIDALE COMPATIBILE

**BASIC MODULE + PARALLEL BELT GEARBOX STAGE +
IN-LINE COMPATIBLE PLANETARY GEARBOX REDUCTION STAGE**

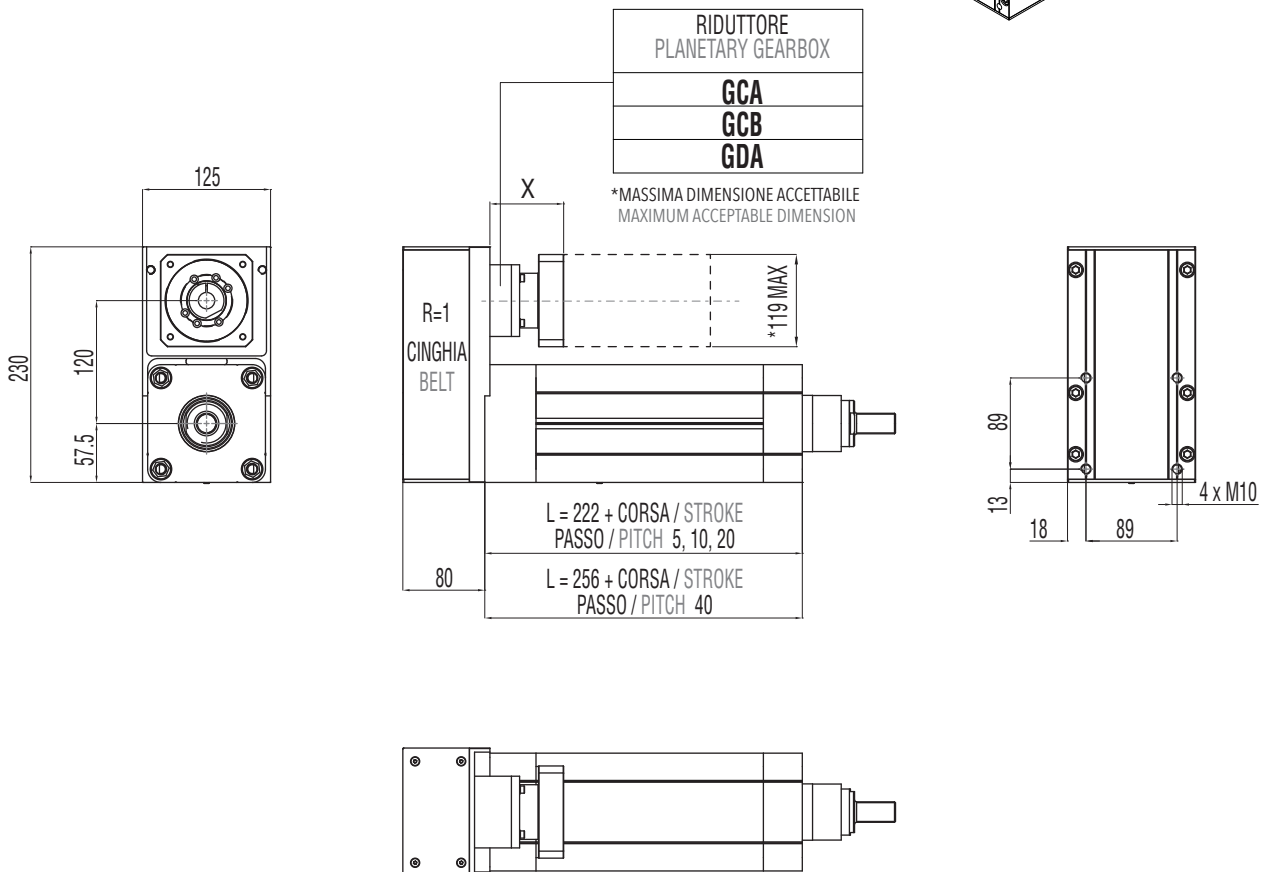
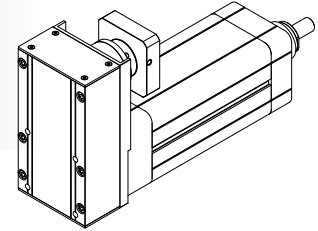

3.8.7 Accessori disponibili

Per le tabelle e i disegni tecnici degli accessori disponibili fare riferimento al paragrafo 3.10 (da pag. 136).

3.8.7 Available accessories

For tables and drawings please refer to paragraph 3.10 (from page 136).

3.9

IE 100 XL

3.9.1 Caratteristiche tecniche

3.9.1 Technical features

ISOMOVE IE 100 XL CON TIRANTI ISOMOVE IE 100 XL WITH TENSION RODS			10
P	PASSO VITE SCREW LEAD	[mm]	10
D	DIAMETRO VITE SCREW DIAMETER	[mm]	50
F_d	CARICO MASSIMO DINAMICO APPLICABILE MAX ADMISSIBLE DYNAMIC LOAD	[N]	52000*
C_{in,max}	PER AVERE $F_a = F_d$ TO GET	[Nm]	92
	"CASO 1" / "CASE 1": B00 + D00/D01	[Nm]	92
	"CASO 2" / "CASE 2": B00 + D02/A01	[Nm]	$\left[\frac{102,2}{R} \right] + C_s$ R = rapporto di riduzione del riduttore / rinvio angolare R = planetary / angle bevel gearbox reduction ratio
C_{m,max}	"CASO 3" / "CASE 3": B00 + R00/R01	[Nm]	$\frac{102,2}{R}$ R = rapporto di riduzione della trasmissione a cinghia (disponibile R=1 oppure R=2) R = belt gearbox reduction ratio (available R=1 or R=2)
	"CASO 4" / "CASE 4": B00 + R02	[Nm]	$\frac{113,5}{R}$ R = rapporto di riduzione del riduttore epicicloidale R = planetary gearbox reduction ratio
F_{st}	CARICO MASSIMO STATICO APPLICABILE MAX ADMISSIBLE STATIC LOAD	[N]	52000*
V_{out,max}	VELOCITÀ DI TRASLAZIONE MASSIMA IN USCITA / ROTAZIONE MASSIMA VITE RDS	[mm/sec]	333/1998
N_{in,max}	MAX OUTPUT SPEED / MAX BALLSCREW ROTATING INPUT SPEED	[rpm]	
a_{max}	ACCELERAZIONE MASSIMA IN USCITA MAX OUTPUT ACCELERATION	[m/sec ²]	2
S_{max}	CORSA MASSIMA STANDARD MAX STANDARD STROKE	[mm]	1100**
	PESO MODULO BASE CORSA 0 mm / PESO OGNI 100 mm DI CORSA BASIC MODULE WEIGHT FOR 0 mm STROKE / WEIGHT FOR ADDITIONAL 100 mm STROKE	[Kg]	11,6 / 4,8
G_{s,max}	GIOCO ASSIALE MASSIMO PER CHIOCCIOLA STANDARD MAX AXIAL BACKLASH FOR STANDARD BALLSCREW ASSEMBLY	mm	0,06
G_z	GIOCO "0" DELLA CHIOCCIOLA "0" BACKLASH BALLSCREW ASSEMBLY		DISPONIBILE / AVAILABLE
L_{10,Km}	DURATA LIFETIME	Km	VEDI TABELLA / SEE TABLE pg. 126









* Per le versioni R00/R01 controllare con i grafici delle pagine 128/129. / For R00/R01 types please check graph at pages 128/129.

** Per corse superiori, contattare il nostro servizio tecnico. / For longer strokes please contact our technical dpt.

ISOMOVE IE 100 XL CON TIRANTI ISOMOVE IE 100 XL WITH TENSION RODS	10
VERSIONI DISPONIBILI AVAILABLE TYPES	D00 / D01 / D02 / R00 / R01 / R02 / A01
F_{a,p} POSSIBILE CON IL RIDUTTORE EPICICLOIDALE INDICATO POSSIBLE VALUE WITH THE INDICATED PLANETARY GEARBOX [N]	AE070/17600*** AE090/43960*** AE120/52000 PGII-080/28575*** PGII-120/52000
POSSIBILE CON IL RINVIO ANGOLARE INDICATO POSSIBLE VALUE WITH THE INDICATED ANGLE BEVEL GEARBOX [N]	ATB090/17600*** ATB0110/37400*** ATB0140/52000
ACCESSORI DISPONIBILI AVAILABLE ACCESSORIES	VEDI PARAGRAFO / SEE PARAGRAPH 3.10 (pg. 136)

*** È il valore massimo ottenibile con il rapporto di riduzione disponibile avente il minore valore di coppia erogabile.
It is the max obtainable value with the available on tables reduction ratio which has the lowest value of nominal output torque.

RIDUTTORI-RINVII "STANDARD SETEC GROUP DISPONIBILI"
"STANDARD SETEC GROUP AVAILABLE" PLANETARY-ANGLE BEVEL GEARBOXES

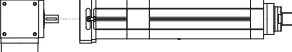
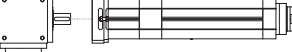
TRASMISSIONE COASSIALE CON RIDUTTORE IN-LINE PLANETARY GEARBOX STAGE	 AE070 MODULO BASE BASIC MODULE	 AE090 MODULO BASE BASIC MODULE	 AE120 MODULO BASE BASIC MODULE
	 PGII-080 MODULO BASE BASIC MODULE	 PGII-120 MODULO BASE BASIC MODULE	
TRASMISSIONE PARALLELA CON RIDUTTORE PARALLEL BELT GEARBOX STAGE + IN-LINE PLANETARY GEARBOX REDUCTION STAGE	 AE070 MODULO BASE BASIC MODULE	 AE090 MODULO BASE BASIC MODULE	 PGII-080 MODULO BASE BASIC MODULE
TRASMISSIONE ANGOLARE CON RINVIO ANGLE BEVEL GEARBOX STAGE	 ATB090 MODULO BASE BASIC MODULE	 ATB110 MODULO BASE BASIC MODULE	 ATB140 MODULO BASE BASIC MODULE

3.9.2 Calcolo durata

3.9.2 Lifetime calculation

<p>IE 100 XL P = 10 mm</p>	$L_{10,Km} = \left[\frac{79300}{F_{eq}} \right]^3 \cdot 10$ <p style="text-align: right;">$L_{10,Km} = [Km]$ $F_{eq} = [N]$</p>
--	--

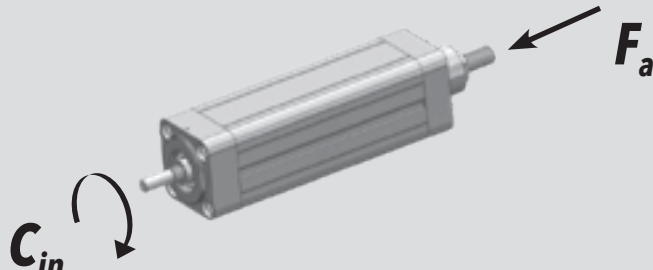

3.9.3 Calcolo coppia in ingresso al modulo base

3.9.3 Torque calculation at basic module input shaft

 <p>The diagram shows a motor with an input shaft. A curved arrow labeled C_{in} indicates the input torque at the shaft. A straight arrow labeled F_a indicates the axial force applied to the shaft.</p>	
<p>IE 100 XL P = 10 mm</p>	$C_{in} = \left[\frac{F_a \cdot 10}{5652} \right]$ <p style="text-align: right;">$C_{in} = [Nm]$ $F_a = [N]$</p>

3.9.4 Calcolo coppia motore

3.9.4 Motor torque calculation

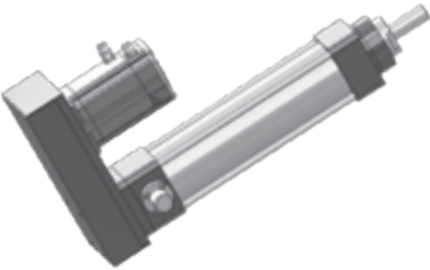
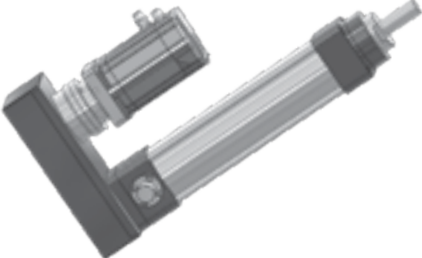
<p>CASO / CASE 1</p>	<p>ISOMOVE B00 + D00 / D01</p>  $C_m = C_{in} \quad [Nm]$
<p>CASO / CASE 2</p>	<p>ISOMOVE B00 + D02 / A01</p>  $C_m = \left[\frac{C_{in}}{R \cdot \eta} \right] + C_s \quad [Nm]$ <p>R = rapporto di riduzione riduttore / rinvio planetary / angle bevel gearbox reduction ratio η = rendimento meccanico / mechanical efficiency = 0,90</p>
<p>CASO / CASE 3</p>	<p>ISOMOVE B00 + R00 / R01</p>  $C_m = \left[\frac{C_{in}}{R \cdot \eta} \right] \quad [Nm]$ <p>R = rapporto di riduzione trasmissione a cinghia, disponibile R=1 o R=2 belt gearbox reduction ratio, available R=1 or R=2 η = rendimento meccanico / mechanical efficiency = 0,90</p>
<p>CASO / CASE 4</p>	<p>ISOMOVE B00 + R02</p>  $C_m = \left[\frac{C_{in}}{R \cdot \eta} \right] + C_s \quad [Nm]$ <p>R = rapporto di riduzione riduttore epicicloidale planetary gearbox reduction ratio η = rendimento meccanico / mechanical efficiency = 0,81</p>

3.9.5 Potenza in ingresso alla trasmissione a cinghia (versione R)

3.9.5 Mechanical input power at belt gear stage (R type)

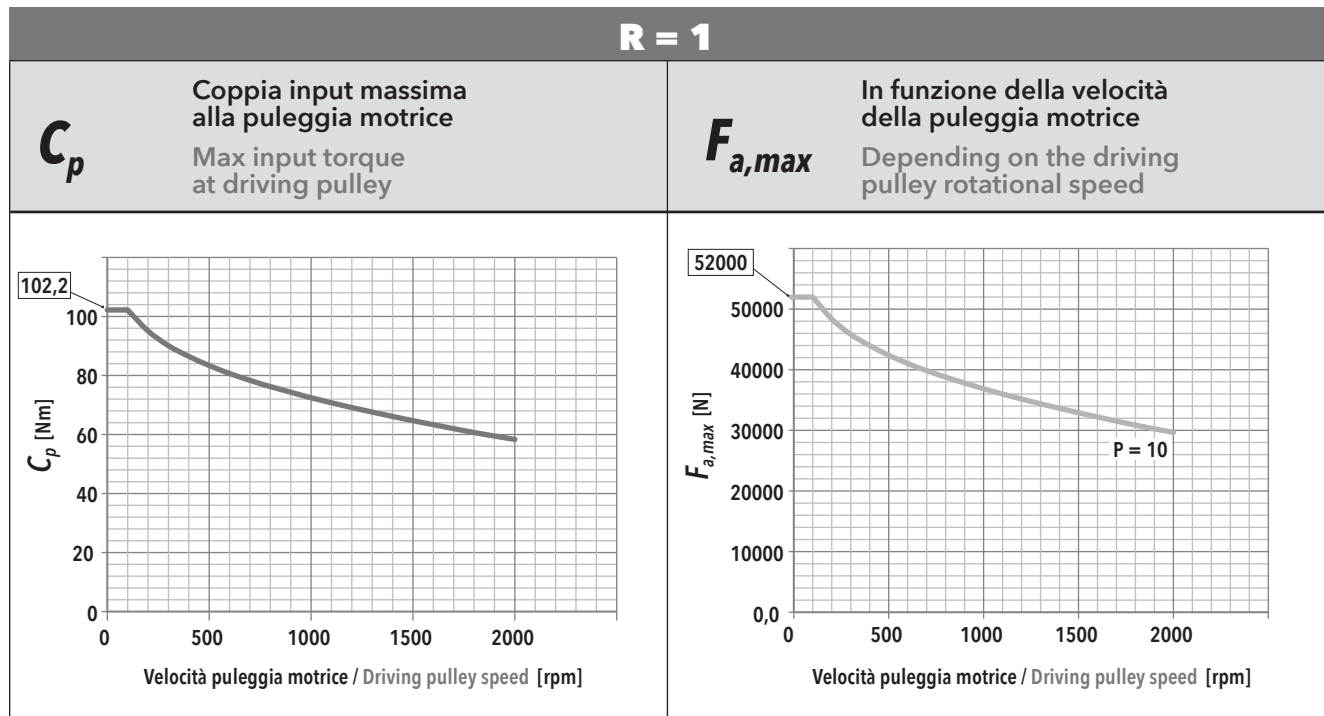

F_r Forza radiale su asse puleggia motrice in funzione di C_{in}
Radial force on driving pulley as a function of C_{in}

f_t Frequenza di vibrazione della cinghia per il tensionamento (al montaggio)
Vibration frequency of the belt for its tensioning (during assembly)

IE 100 XL - PASSO / PITCH 10					
F_a [N]		V_{out} [mm/s]			
		33	133	233	333
52000	F_r [N]	3051			
	f_t [Hz]	461			
46800	F_r [N]	2746			
	f_t [Hz]	438			
41600	F_r [N]	2441	2443		
	f_t [Hz]	413	413		
36400	F_r [N]	2136	2138		
	f_t [Hz]	386	386		
31200	F_r [N]	1831	1833	1838	
	f_t [Hz]	357	357	358	
26000	F_r [N]	1526	1528	1533	1541
	f_t [Hz]	326	326	327	328
20800	F_r [N]	1221	1223	1228	1236
	f_t [Hz]	292	292	293	294
15600	F_r [N]	916	918	923	931
	f_t [Hz]	253	253	254	255
10400	F_r [N]	610	613	618	626
	f_t [Hz]	206	207	208	209
5200	F_r [N]	309	311	317	325
	f_t [Hz]	147	147	149	150

R = 2

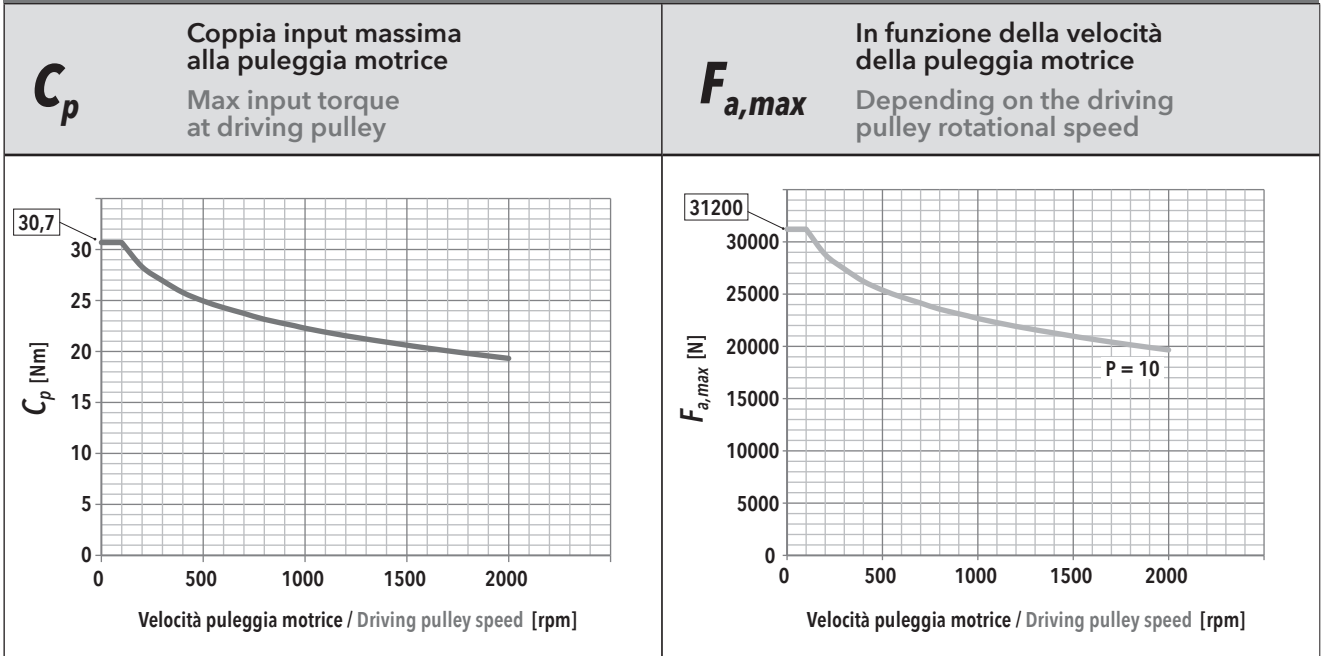

F_r Forza radiale su asse puleggia motrice in funzione di C_{in}
Radial force on driving pulley as a function of C_{in}

f_t Frequenza di vibrazione della cinghia per il tensionamento (al montaggio)
Vibration frequency of the belt for its tensioning (during assembly)

IE 100 XL - PASSO / PITCH 10					
F_a [N]		V_{out} [mm/s]			
		16,6	66,4	116,2	166
52000	F_r [N]				
	f_t [Hz]				
46800	F_r [N]				
	f_t [Hz]				
41600	F_r [N]				
	f_t [Hz]				
36400	F_r [N]				
	f_t [Hz]				
31200	F_r [N]				
	f_t [Hz]				
26000	F_r [N]	1573			
	f_t [Hz]	403			
20800	F_r [N]	1258	1259	1260	
	f_t [Hz]	360	360	360	
15600	F_r [N]	944	944	946	946
	f_t [Hz]	312	312	312	312
10400	F_r [N]	629	630	631	632
	f_t [Hz]	255	255	255	255
5200	F_r [N]	315	315	317	317
	f_t [Hz]	180	180	181	181

3.9.6 Caratteristiche dimensionali

3.9.6 Overall dimensions

NOTA: Dati categorie motori / riduttori / rinvi al capitolo 4.

REMARK: Motors / Planetary / Angle bevel gearbox categories data at chapter 4.

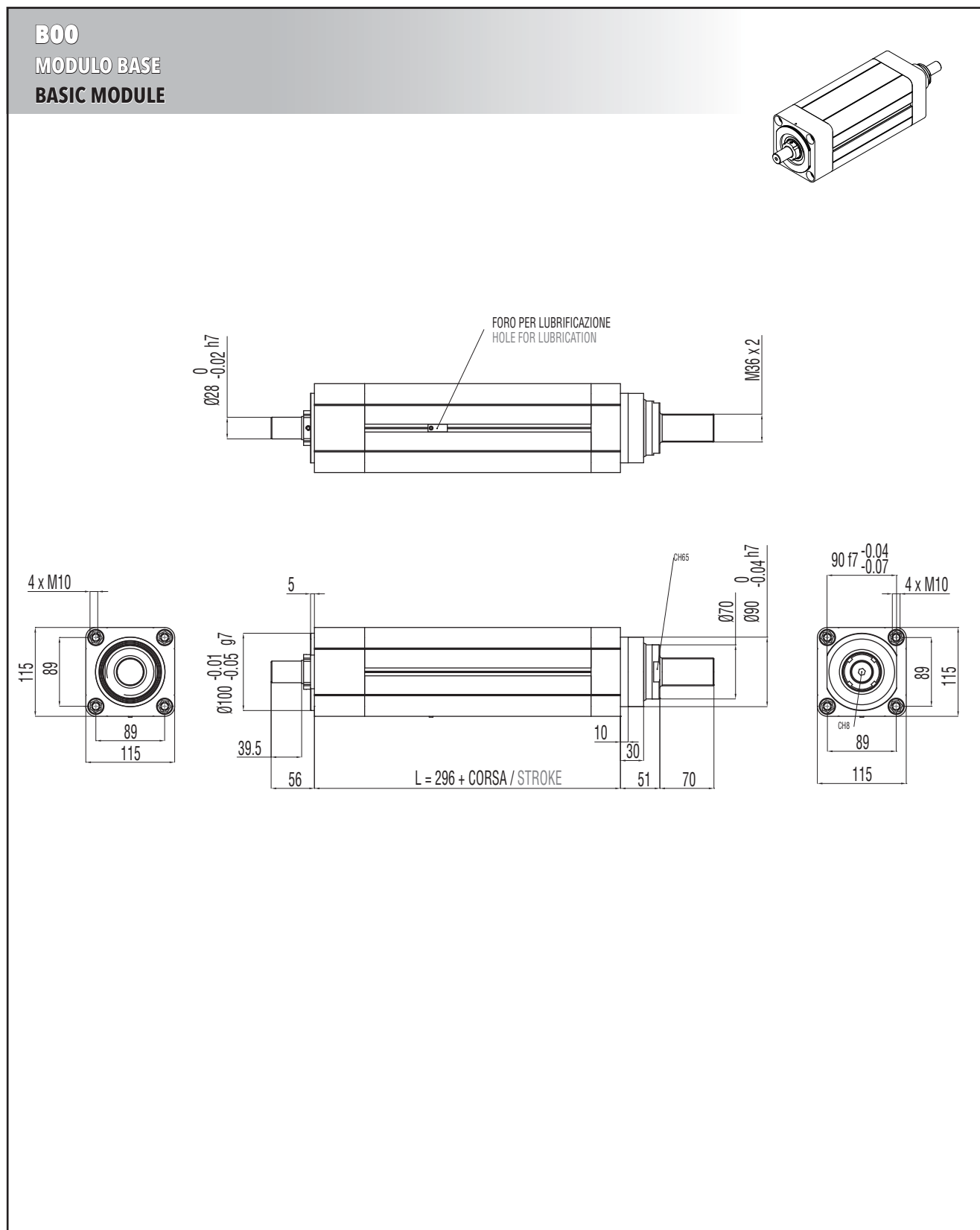

B00 + D00

MODULO BASE + TRASMISSIONE COASSIALE PER MOTORE CUSTOM
(SENZA RIDUTTORE)

**BASIC MODULE + CUSTOM IN-LINE TRANSMISSION W/O REDUCTION STAGE
FOR CUSTOM MOTORS**

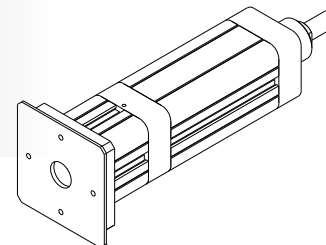

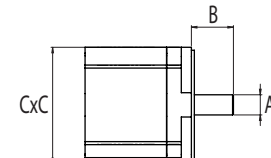
	DIMENSIONI LIMITI INTERFACCIA MAX INTERFACE DIMENSIONS			
	TAGLIA GIUNTO COUPLING SIZE	A [mm]	B [mm]	C [mm]
	150	30 max	40 min / 52 max	130 max

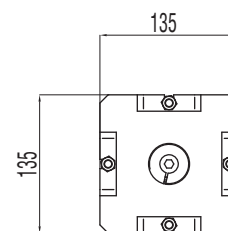
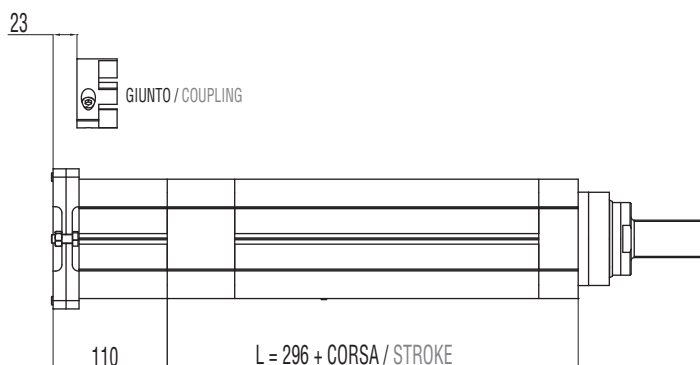

B00 + D01

MODULO BASE + TRASMISSIONE COASSIALE PER MOTORE COMPATIBILE
(SENZA RIDUTTORE)

**BASIC MODULE + IN-LINE TRANSMISSION W/O REDUCTION STAGE FOR
COMPATIBLE MOTORS**

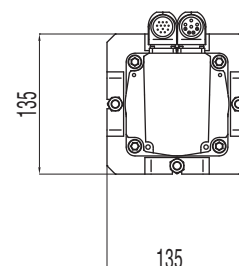
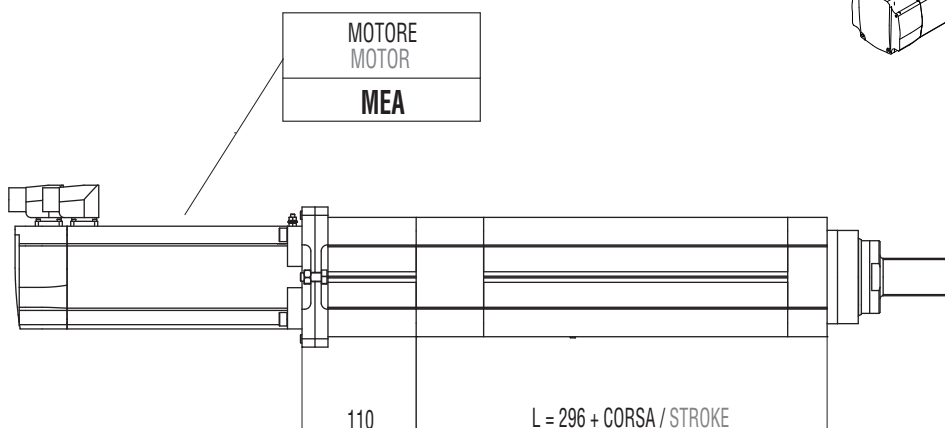
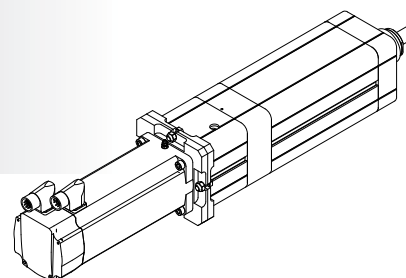

B00 + D02

MODULO BASE + RIDUTTORE EPICICLOIDALE COASSIALE COMPATIBILE

BASIC MODULE + IN-LINE COMPATIBLE PLANETARY GEARBOX REDUCTION STAGE

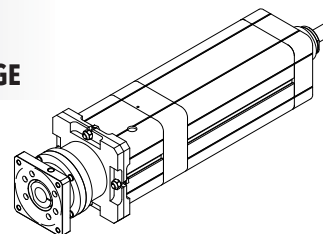

RIDUTTORE / PLANETARY GEARBOX
GCA*
GDA**
GEA***
GCB*
GEB**

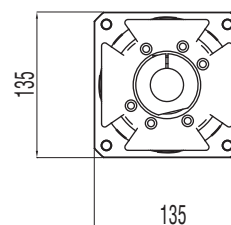
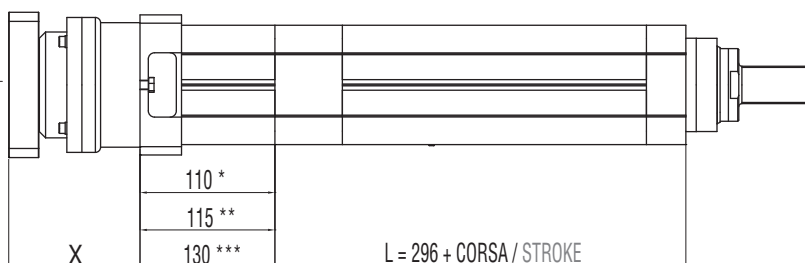

B00 + A01

MODULO BASE + RINVIO ANGOLARE COMPATIBILE

BASIC MODULE + COMPATIBLE ANGLE BEVEL GEARBOX STAGE

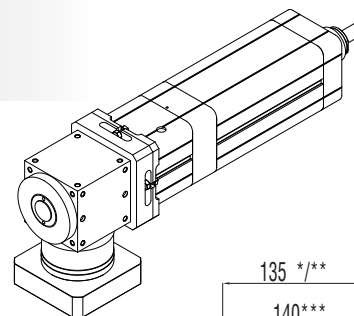

RINVIO ANGOLARE ANGLE BEVEL GEARBOX
ACA*
ADA**
AEA***

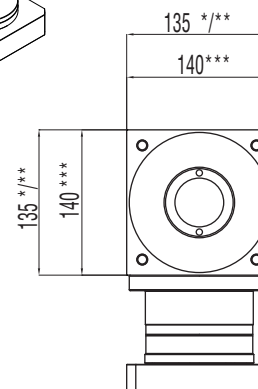
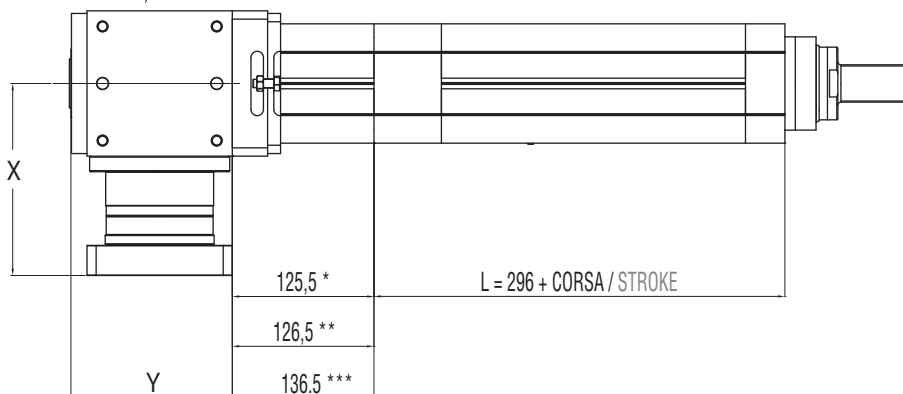

B00 + R00

MODULO BASE + TRASMISSIONE A CINGHIA IN PARALLELO PER MOTORE CUSTOM

BASIC MODULE + PARALLEL CUSTOM BELT GEARBOX STAGE FOR CUSTOM MOTORS

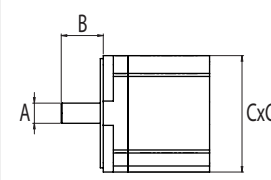

DIMENSIONI LIMITI INTERFACCIA MAX INTERFACE DIMENSIONS			
	A	B	C
	[mm]	[mm]	[mm]
R=1:1	24 max	42 min / 58 max	110 max
R=1:2	19 max	36 min / 50 max	110 max

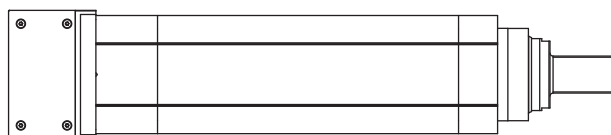
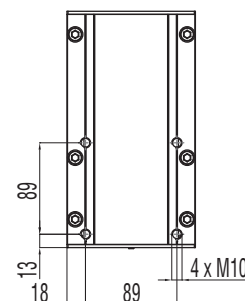
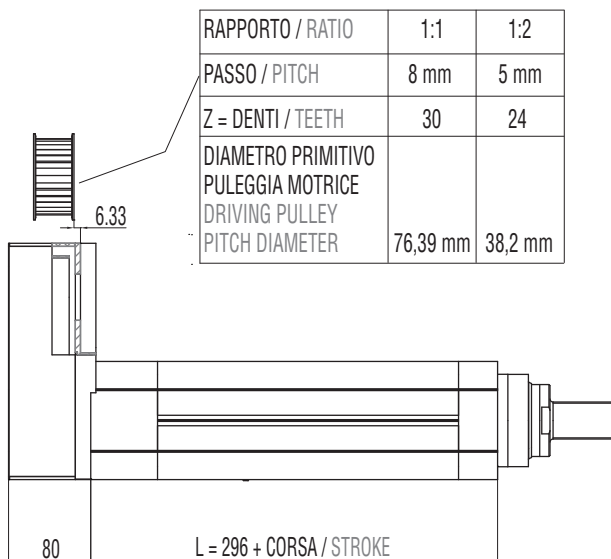
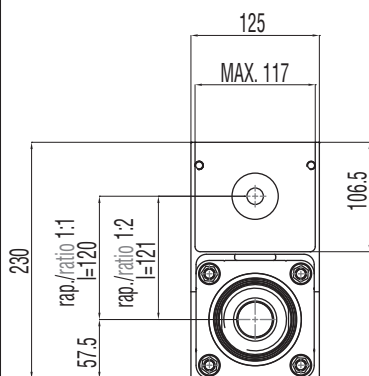
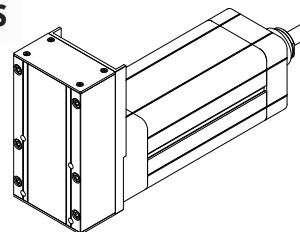

B00 + R01

MODULO BASE + TRASMISSIONE A CINGHIA IN PARALLELO PER MOTORE COMPATIBILE

BASIC MODULE + PARALLEL BELT GEARBOX STAGE FOR COMPATIBLE MOTORS

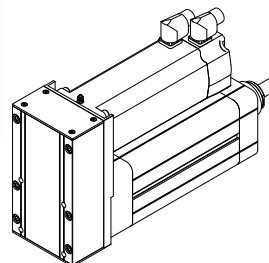

MOTORE MOTOR
MEA
MCA
MCB
MCC
MCD
MDA
MDB
MDC

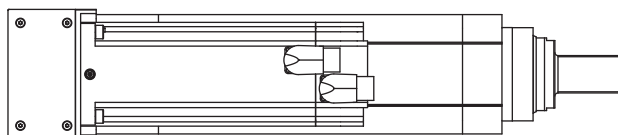
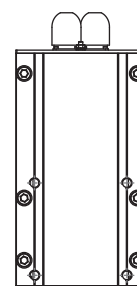
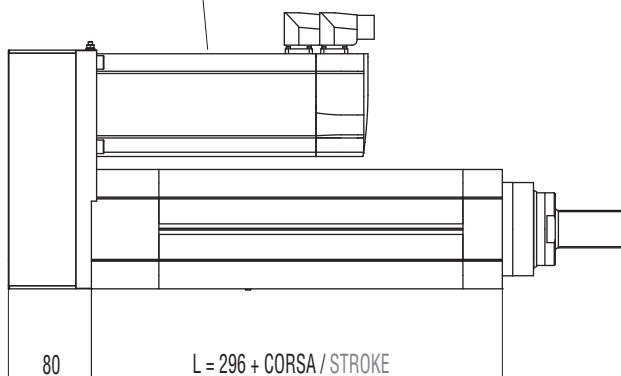
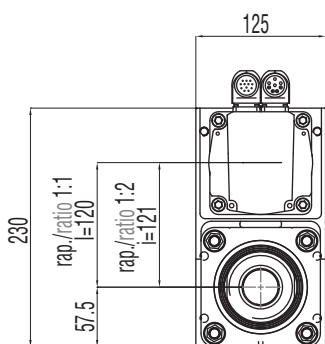

B00 + R02

MODULO BASE + TRASMISSIONE A CINGHIA IN PARALLELO +
RIDUTTORE EPICICLOIDALE COMPATIBILE

**BASIC MODULE + PARALLEL BELT GEARBOX STAGE +
IN-LINE COMPATIBLE PLANETARY GEARBOX REDUCTION STAGE**

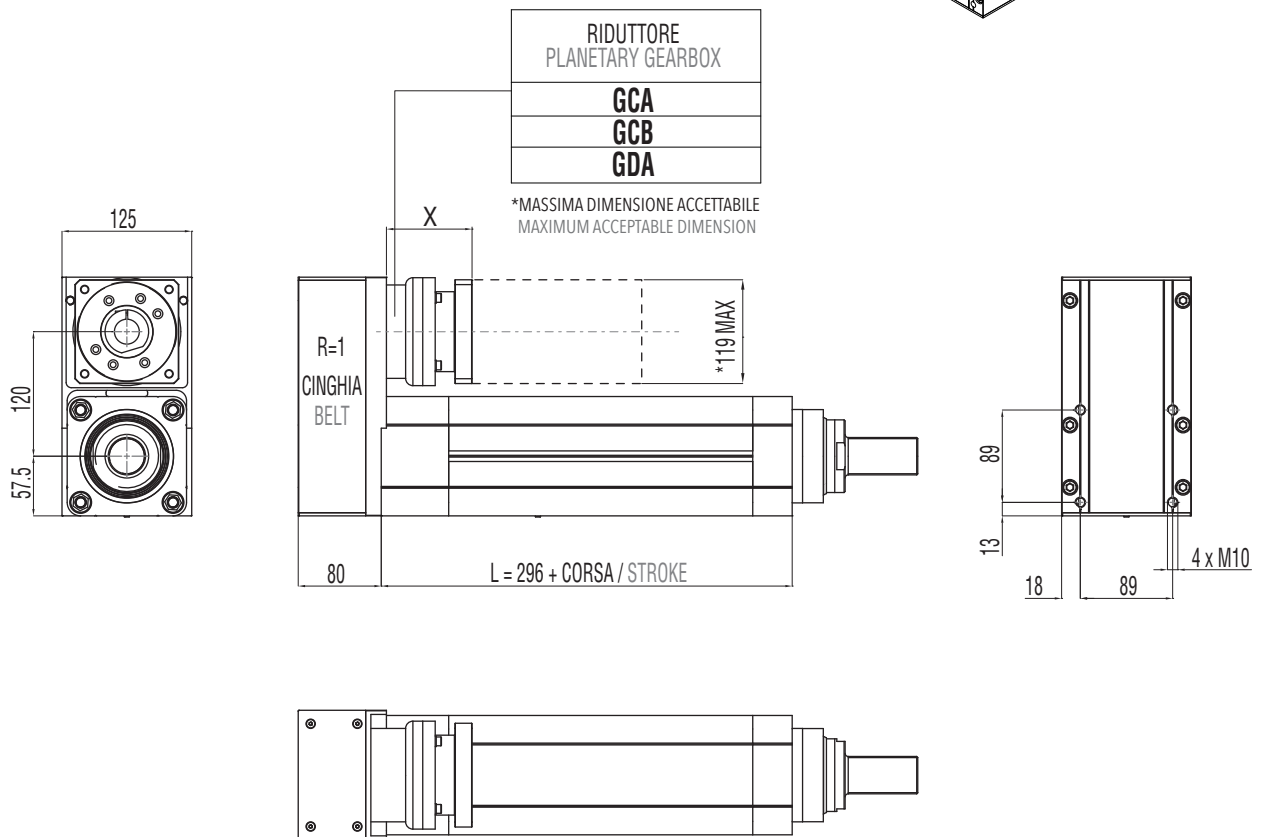
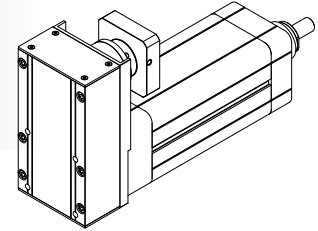

3.9.7 Accessori disponibili

Per le tabelle e i disegni tecnici degli accessori disponibili fare riferimento al paragrafo 3.10 (da pag. 136).

3.9.7 Available accessories

For tables and drawings please refer to paragraph 3.10 (from page 136).

3.10

Accessori da grandezze IE 32 a IE 100 XL
Accessories from IE 32 to IE 100 XL sizes

3.10.1

FS Forcella Stelo
Rod Fork

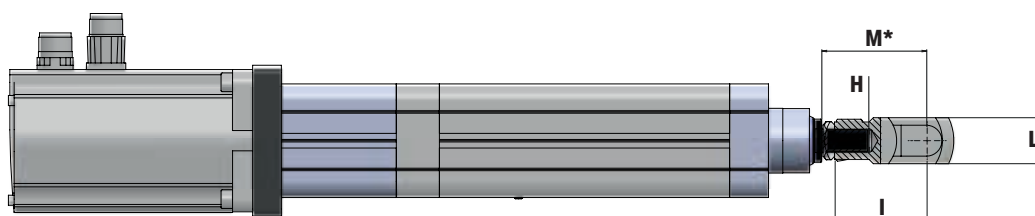
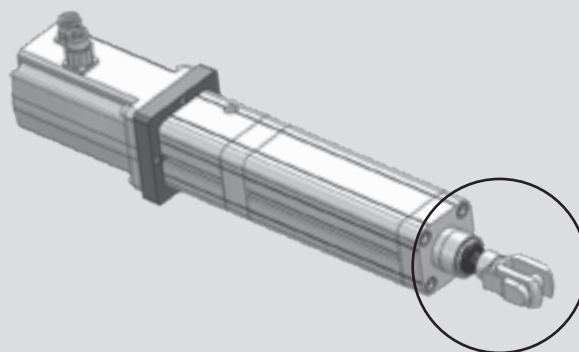

*QUOTA MINIMA, REGOLAZIONE A CARICO DEL CLIENTE
MINIMUM DIMENSION, REGULATION MADE BY THE CUSTOMER

TAGLIA / SIZES	A	B	C	D	E	F	G	H	I	L	M
32	52	20	10	20	26	Ø 18	Ø 10 h 8	M10 x 1.25	40	20	48
40	62	24	12	24	32	Ø 20	Ø 12 h 8	M12 x 1.25	48	24	57
50	83	32	16	32	40	Ø 26	Ø 16 h 8	M16 x 1.5	64	32	74
63	83	32	16	32	40	Ø 26	Ø 16 h 8	M16 x 1.5	64	32	74
80	105	40	20	40	48	Ø 34	Ø 20 h 8	M20 x 1.5	80	40	92
80HL	105	40	20	40	48	Ø 34	Ø 20 h 8	M20 x 1.5	80	40	92
100	105	40	20	40	48	Ø 34	Ø 20 h 8	M20 x 1.5	80	40	92
100HL	105	40	20	40	48	Ø 34	Ø 20 h 8	M20 x 1.5	80	40	92
100XL	188	72	35	70	83	Ø 60	Ø 35 h 8	M36 x 2	144	70	162

3.10.2

SS Snodo Sferico
Swivel Joint

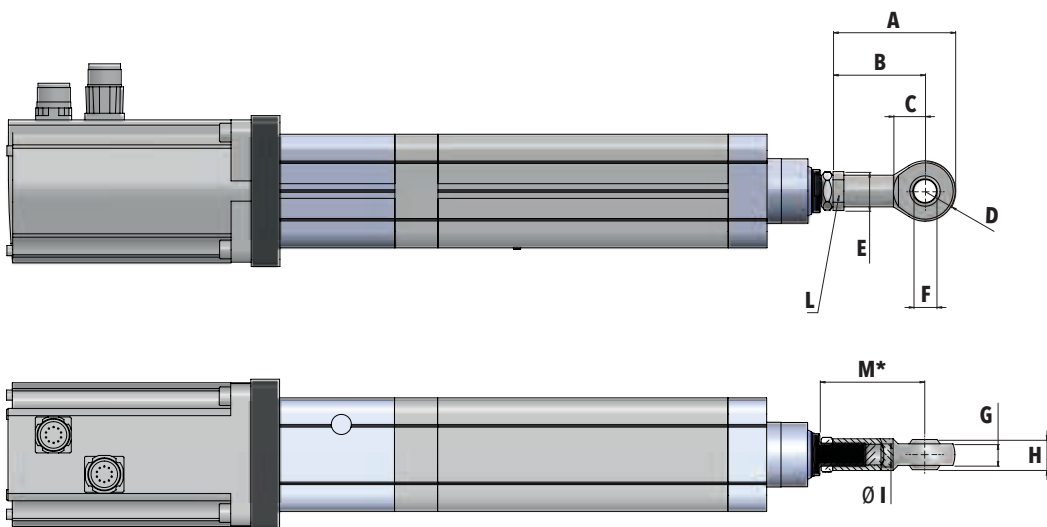
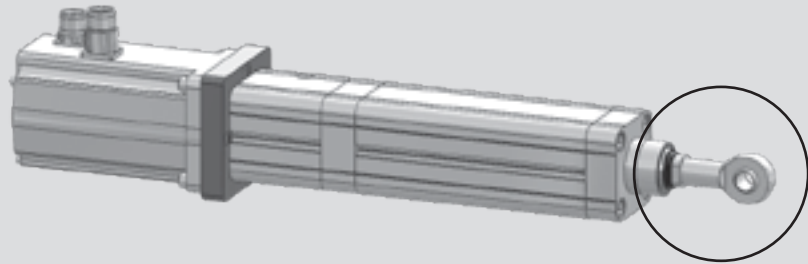

*QUOTA MINIMA, REGOLAZIONE A CARICO DEL CLIENTE
MINIMUM DIMENSION, REGULATION MADE BY THE CUSTOMER

TAGLIA / SIZES	A	B	C	D	E	F	G	H	I	L	M
32	57	43	15	14	Ø 19	Ø 10 H 7	10.5	14	M10 x 1.25	CH17	51
40	66	50	16	16	Ø 22	Ø 12 H 7	12	16	M12 x 1.25	CH19	59
50	85	64	22	21	Ø 27	Ø 16 H 7	15	21	M16 x 1.5	CH22	74
63	85	64	22	21	Ø 27	Ø 16 H 7	15	21	M16 x 1.5	CH22	74
80	102	77	26	25	Ø 34	Ø 20 H 7	18	25	M20 x 1.5	CH30	89
80HL	102	77	26	25	Ø 34	Ø 20 H 7	18	25	M20 x 1.5	CH30	89
100	102	77	26	25	Ø 34	Ø 20 H 7	18	25	M20 x 1.5	CH30	89
100HL	102	77	26	25	Ø 34	Ø 20 H 7	18	25	M20 x 1.5	CH30	89
100XL	165	125	41	40	Ø 58	Ø 35 H 7	28	43	M36 x 2	CH50	143

3.10.3

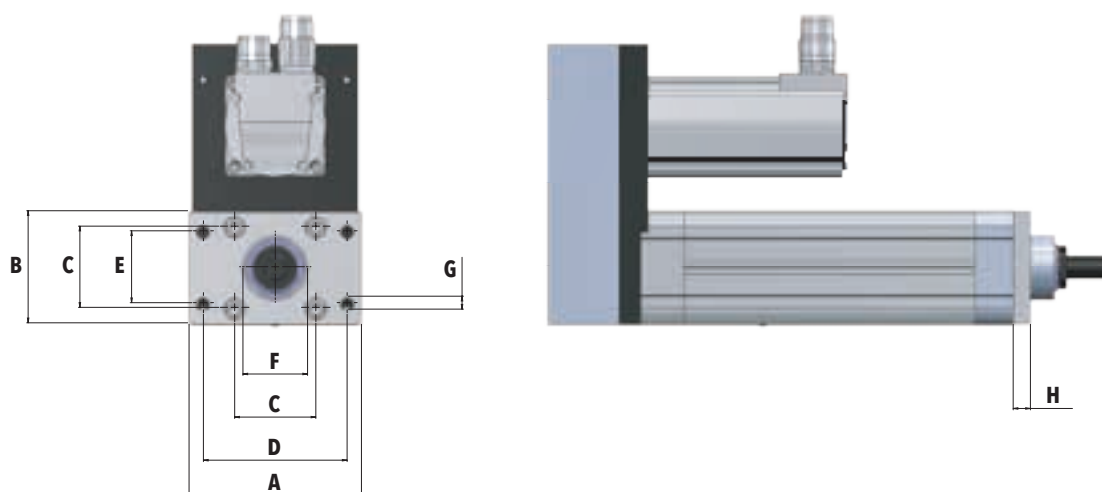
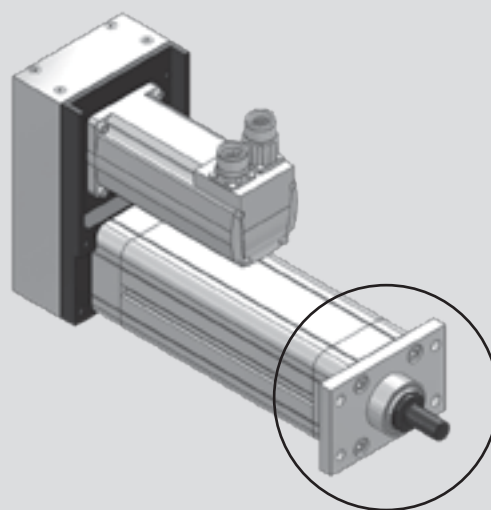
FV Flangia Frontale
Front Flange

TAGLIA / SIZES	A	B	C	D	E	F	G	H
32	80	50	32,5	64	32	Ø 30 H7	4 x Ø 7	10
40	90	55	38	72	36	Ø 35 H7	4 x Ø 9	10
50	110	66	46,5	90	45	Ø 40 H7	4 x Ø 9	12
63	120	78	56,5	100	50	Ø 45 H7	4 x Ø 9	12
80	153	98	72	126	63	Ø 45 H7	4 x Ø 12	16
80HL	153	98	72	126	63	Ø 55 H7	4 x Ø 12	16
100	178	115	89	150	75	Ø 55 H7	4 x Ø 14	16
100HL	178	115	89	150	75	Ø 75 H7	4 x Ø 14	16
100XL	178	115	89	150	75	Ø 90 H7	4 x Ø 14	16

3.10.4

PV Piedino Verticale
Angle Foot

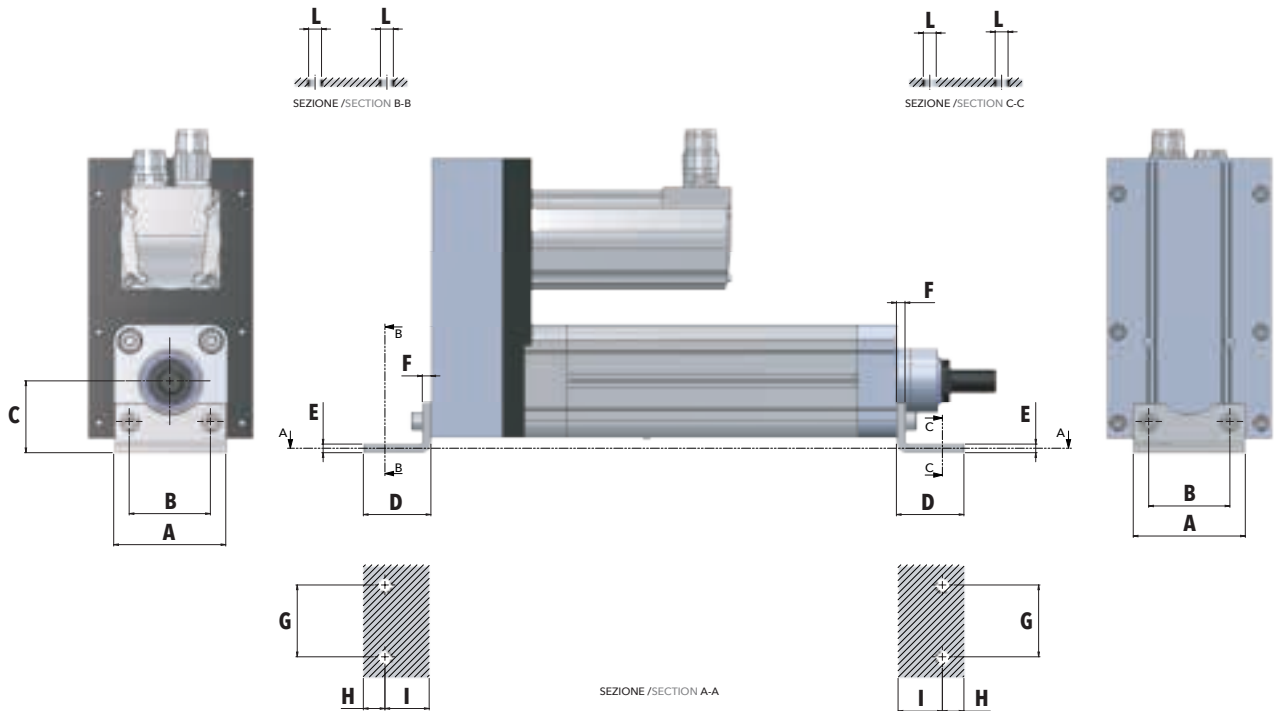
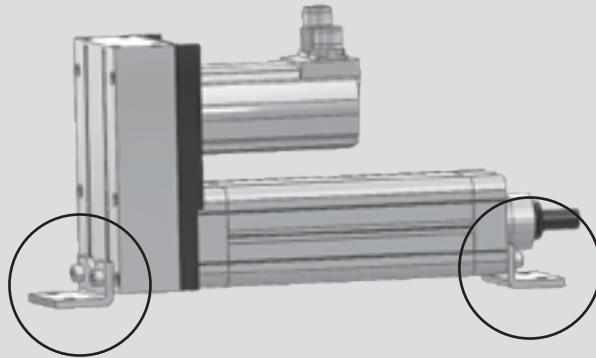

TAGLIA / SIZES	A	B	C	D	E	F	G	H	I	L
32	47	32,5	32	35	5	5	32	11	24	Ø 7
40	54	38	36	43	5	5	36	15	28	Ø 9
50	66	46,5	45	47	6	6	45	15	32	Ø 9
63	78	56,5	50	47	6	6	50	15	32	Ø 9
80	98	72	63	61	7	7	63	20	41	Ø 12
80HL	98	72	63	61	7	7	63	20	41	Ø 12
100	115	89	71	66	7	7	75	25	41	Ø 14
100HL	115	89	71	66	7	7	75	25	41	Ø 14
100XL	115	89	71	66	7	7	75	25	41	Ø 14

3.10.5

CF Cerniera Femmina
Rear Female Clevis with Pin

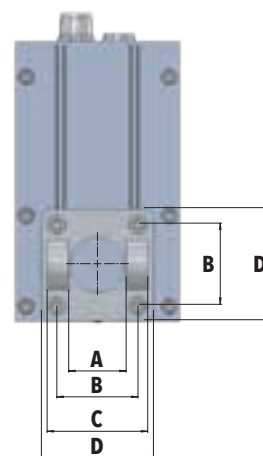
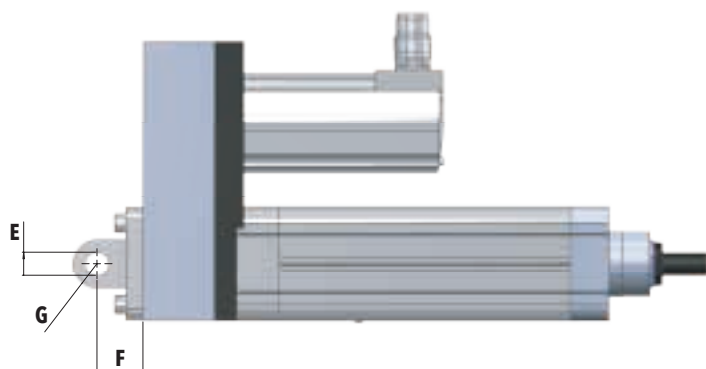
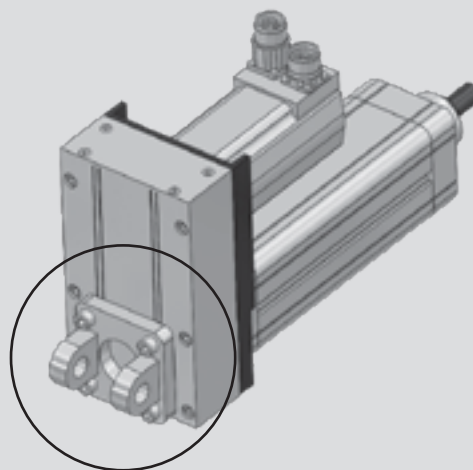

TAGLIA / SIZES	A	B	C	D	E	F	G
32	26	32,5	45	47	Ø 10 H9	22	11
40	28	38	52	54	Ø 12 H9	25	13
50	32	46,5	60	66	Ø 12 H9	27	13
63	40	56,5	70	78	Ø 16 H9	32	17
80	50	72	90	98	Ø 16 H9	36	17
80HL	50	72	90	98	Ø 16 H9	36	17
100	60	89	110	115	Ø 20 H9	41	21
100HL	60	89	110	115	Ø 20 H9	41	21
100XL	60	89	110	115	Ø 20 H9	41	21

3.10.6

KO Controcerniera Orizzontale
Square Horizontal Counterclevis

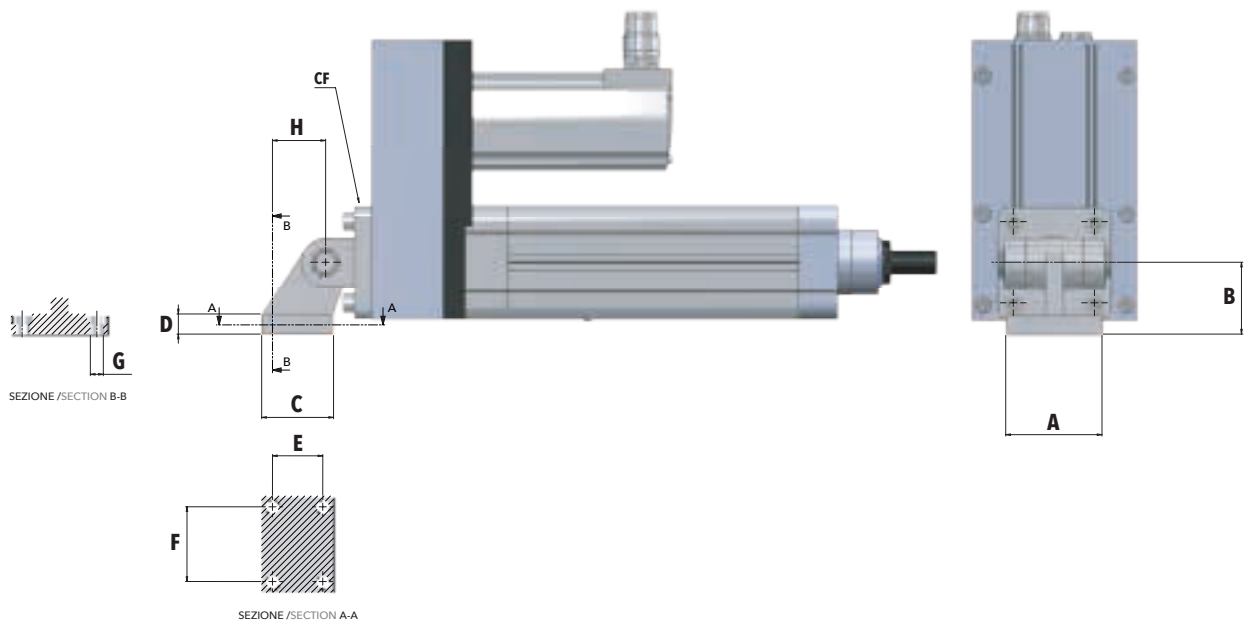
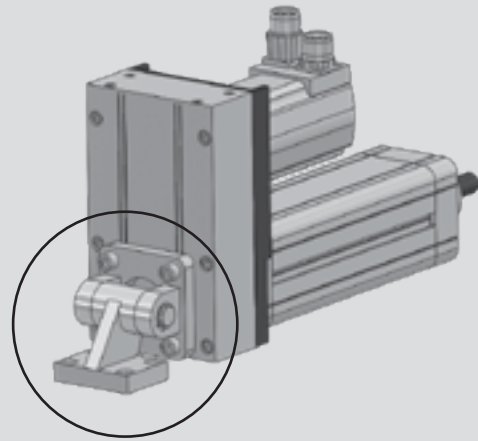

TAGLIA / SIZES	A	B	C	D	E	F	G	H
32	51	32	31	8	18	38	Ø 6,6	21
40	54	36	35	10	22	41	Ø 6,6	24
50	65	45	45	12	30	50	Ø 9	33
63	67	50	50	14	35	52	Ø 9	37
80	86	63	60	14	40	66	Ø 11	47
80HL	86	63	60	14	40	66	Ø 11	47
100	96	71	70	17	50	76	Ø 11	55
100HL	96	71	70	17	50	76	Ø 11	55
100XL	96	71	70	17	50	76	Ø 11	55

3.10.7

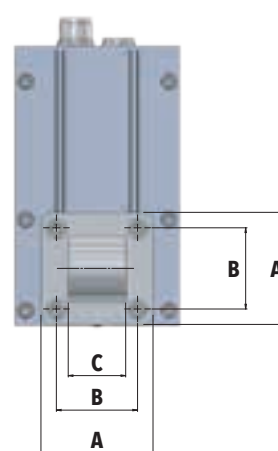
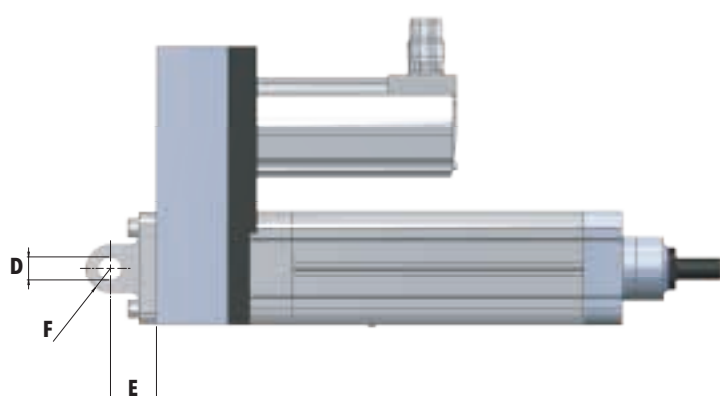
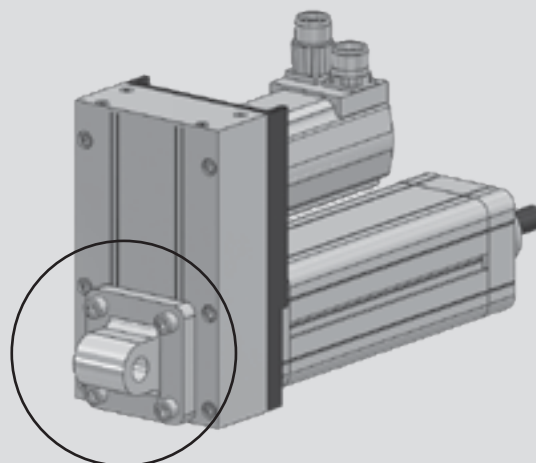
KM Controcerniera Maschio
Male Clevis

TAGLIA / SIZES	A	B	C	D	E	F
32	47	32,5	26	Ø 10 H7	22	11
40	54	38	28	Ø 12 H7	25	13
50	66	46,5	32	Ø 12 H7	27	13
63	78	56,5	40	Ø 16 H7	32	17
80	98	72	50	Ø 16 H7	36	17
80HL	98	72	50	Ø 16 H7	36	17
100	115	89	60	Ø 20 H7	41	21
100HL	115	89	60	Ø 20 H7	41	21
100XL	115	89	60	Ø 20 H7	41	21

3.10.8

KS Controcerniera Sferica
Male Clevis with Spherical Knuckle

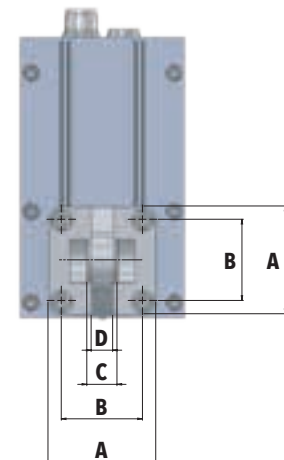
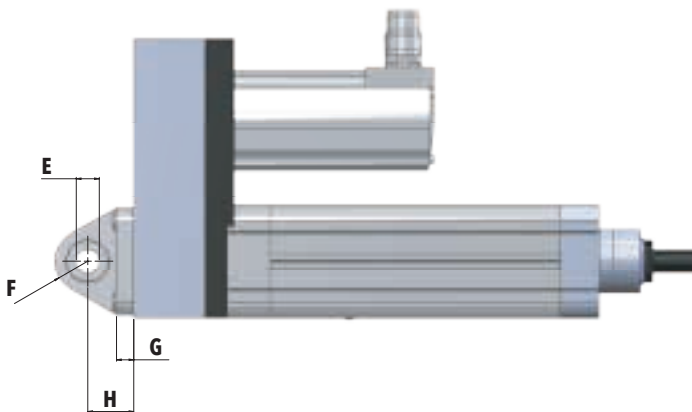
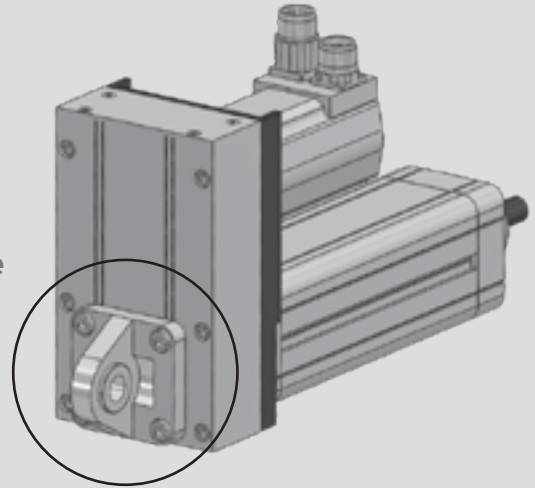

TAGLIA / SIZES	A	B	C	D	E	F	G	H
32	45	32,5	14	10,5	Ø 10 H7	15	10	22
40	55	38	16	12	Ø 12 H7	18	10	25
50	65	46,5	21	15	Ø 16 H7	20	10	27
63	75	56,5	21	15	Ø 16 H7	23	12	32
80	95	72	25	18	Ø 20 H7	27	14	36
80HL	95	72	25	18	Ø 20 H7	27	14	36
100	115	89	25	18	Ø 20 H7	30	16	41
100HL	115	89	25	18	Ø 20 H7	30	16	41
100XL	115	89	25	18	Ø 20 H7	30	16	41

3.10.9

PE Perni Oscillanti
Pivoting Pins

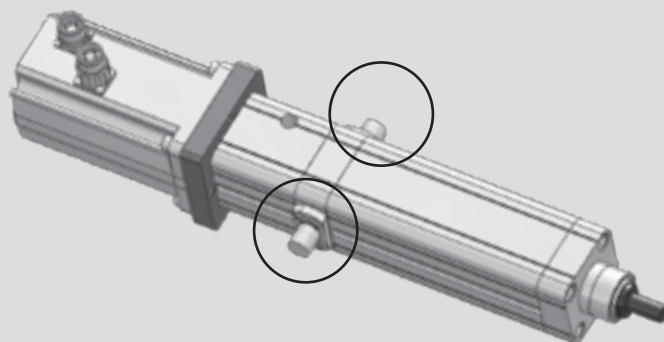

COASSIALE / IN-LINE VERSION

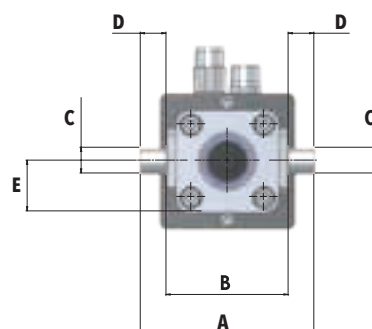
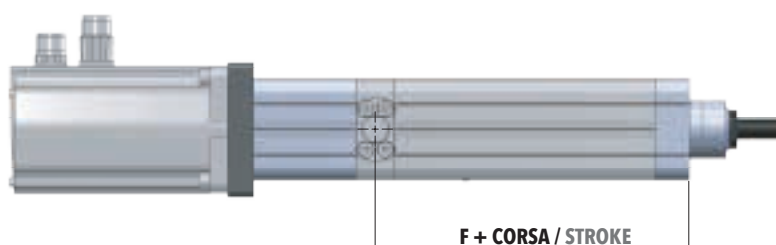

PARALLELO / BELT GEARBOX STAGE

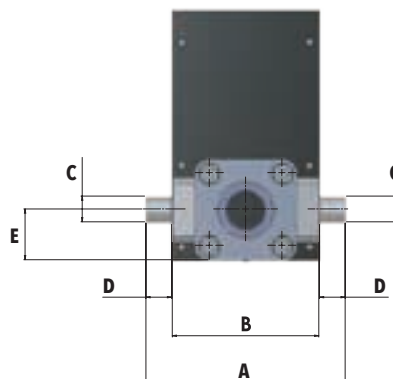
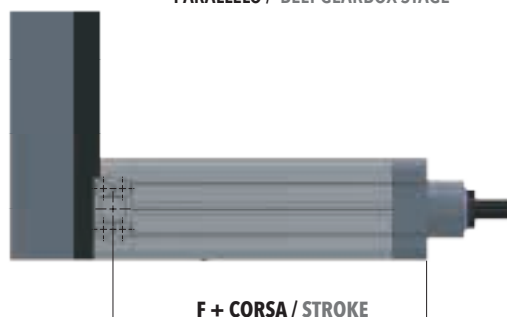

TAGLIA / SIZES	A	A	B	B	C	D	E	F
	COASSIALE IN-LINE VERSION	PARALLELO BELT GEARBOX STAGE	COASSIALE IN-LINE VERSION	PARALLELO BELT GEARBOX STAGE				
32	91	91	67	67	Ø 12 g7	12	25	130
40	96	96	72	72	Ø 12 g7	12	27,5	130
50	120	147	88	115	Ø 16 g7	16	34	122,5
63	135	155	95	115	Ø 20 g7	20	39,5	144
80	169	169	129	129	Ø 20 g7	20	49	175
80HL	169	169	129	129	Ø 20 g7	20	49	211
100	190	190	140	140	Ø 25 g7	25	57,5	185
100HL*	190	190	140	140	Ø 25 g7	25	57,5	197
100HL**	190	190	140	140	Ø 25 g7	25	57,5	231
100XL	190	190	140	140	Ø 25 g7	25	57,5	263,5

* Vite Ø 40 con passo 5, 10, 20 / Ballscrew Ø 40 with pitch 5, 10, 20

** Vite Ø 40 con passo 40 / Ballscrew Ø 40 with pitch 40

3.11

Sistemi di guida
Guiding unit

3.11.1

Tipo "H"
"H" Type

COASSIALE / IN-LINE VERSION

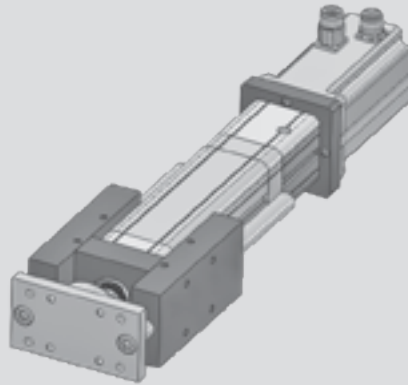

PARALLELO / BELT GEARBOX STAGE



TABELLA PESI / WEIGHT

TAGLIA SIZES	PESO CORSA WEIGHT STROKE	PESO ogni 100 mm di CORSA WEIGHT a 100 mm STROKE
Ø [mm]	[kg]	[kg]
32	1,3	0,18
40	2,4	0,31
50	3,5	0,48
63	4,6	0,48
80 80 HL	8,4	0,77
100 100 HL 100 XL	11,8	0,77

TABELLA DIMENSIONALE / OVERALL DIMENSION

TAGLIA SIZES	GIUNTO LUNGO LONG COUPLING																							GIUNTO CORTO SHORT COUPLING								
	A	B	C	CH1	CH2	D	E	F	G	H	I	L1	L2	L3	L4	L5	L6	M	N	O	P	Q	R	T	U	V	V1	Z	L1	L2	L6	V
Ø [mm]	[mm]																															
32	97	49	51	15	17	24	4,3	93	45	12	12	25	42	75	125	187	25	6	6,6	12	11	6,5	M6	78	61	32,5	82,7	74	3	19	47	60,7
40	115	58	58	15	19	28	11	112	55	12	16	25	42	80	140	207	30	7	6,6	12	11	6,5	M6	84	69	38	86	87	3	24	52	64
50	137	70	70	20	24	34	18,8	134	65	15	20	25	50	78	148	223	35	8	9	16	15	9	M8	100	85	46,5	92	104	3	27	57	70
63	152	85	85	20	24	34	15,3	147	80	15	20	25	50	106	178	243	25	8	9	16	15	9	M8	105	100	56,5	96,7	119	3	27	47	74,7
80 80 HL	189	105	105	26	30	50	25	180	100	20	25	25	50	111	195	267	27	9	11	20	18	11	M10	130	130	72	104	148	3	27	49	82
100 100 HL 100 XL	213	130	131	26	30	55	30	206	120	20	25	25	50	128	218	290	27	9	11	20	18	11	M10	150	150	89	105	173	3	27	49	83

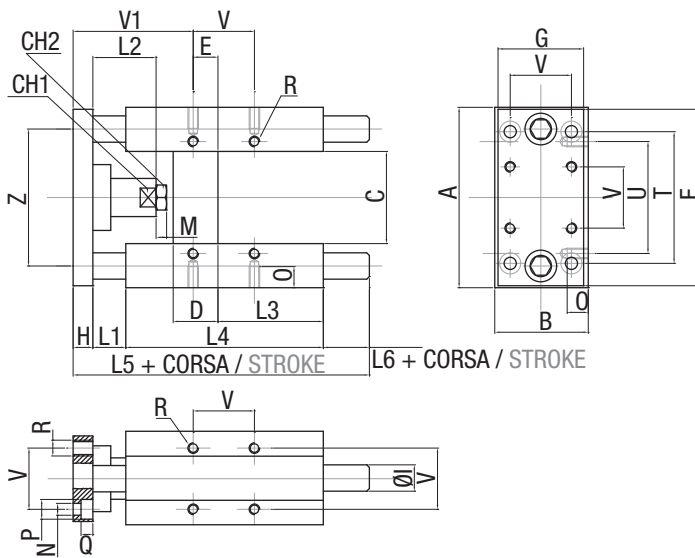
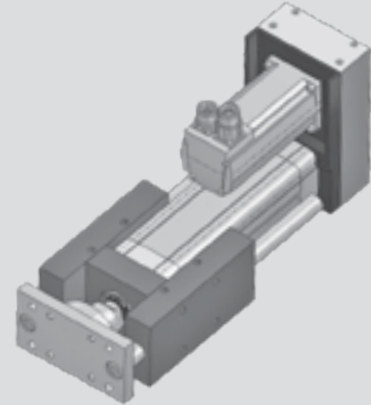
3.11.2

COASSIALE / IN-LINE VERSION

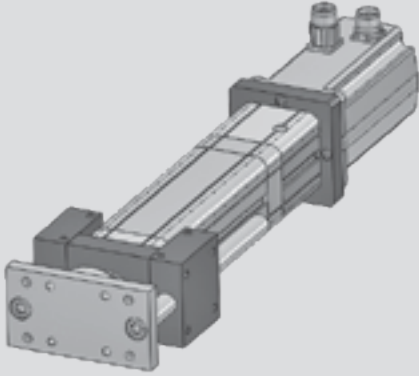

PARALLELO / BELT GEARBOX STAGE

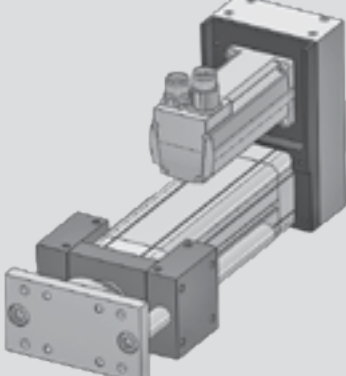

Tipo "U"
"U" Type

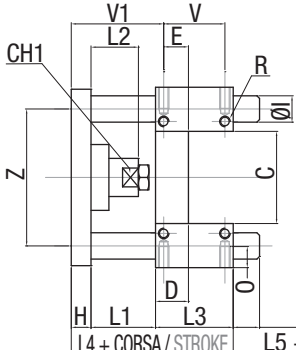
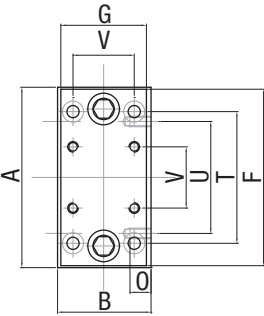
L4 + CORSA / STROKE L5 + CORSA / STROKE



TABELLA DIMENSIONALE / OVERALL DIMENSION

TAGLIA SIZES	GIUNTO LUNGO / LONG COUPLING																								
	A	B	C	CH	D	E	F	G	H	I	L1	L2	L3	L4	L5	N	O	P	Q	R	T	U	V	V1	Z
Ø [mm]	[mm]																								
32	97	49	51	15	17	9,25	93	45	12	12	42	25	48	102	18	6,6	12	11	6,5	M6	78	61	32,5	61,75	74
40	115	58	58,2	15	21	11	112	55	12	16	43	25	58	113	17	6,6	12	11	6,5	M6	84	69	38	65	87
50	137	70	70,2	20	25	18,8	134	65	15	20	49	29	59	123	20	9	16	15	8,5	M8	100	85	46,5	70,2	104
63	152	85	85,2	20	25	15,3	147	80	15	20	49	29	76	140	21	9	16	15	9	M8	105	100	56,5	73,7	119

3.11.3 Codice di ordinazione

3.11.3 Designation code

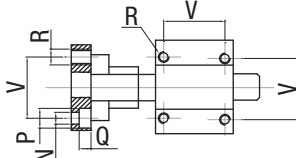
VERSIONE TYPE	ALESAGGIO CILINDRO BORE CYLINDER	CORSA / STROKE [mm]	CARATTERISTICHE SPECIALI SPECIAL FEATURES
SUGM Unità tipo "H" con manicotti a ricircolo di sfere Guiding unit type "H" with vall sleeves	32 40 50 63 80 / 80 HL 100 / 100 HL / 100 XL		
SUGB Unità tipo "H" con bussole sinterizzate autolubrificanti Guiding unit type "H" with self lubricating sintered bronze			
SUGU Unità tipo "U" con bussole sinterizzate autolubrificanti Guiding unit type "U" with self lubricating sintered bronze			

ESEMPIO / EXAMPLE

SUGB	-	63	-	200	-	-
------	---	----	---	-----	---	---

4.

Categorie Motori/Riduttori/Rinvii angolari compatibili (32 ÷ 100XL)

Compatible Motors/ Planetary
gearboxes/Angle bevel gearboxes
categories (32 ÷ 100XL Sizes)

Motori / Motors pg. 148

Riduttori / Planetary gearboxes pg. 149

Rinvii angolari / Angle bevel gearboxes pg. 150

4.1

Motori Motors

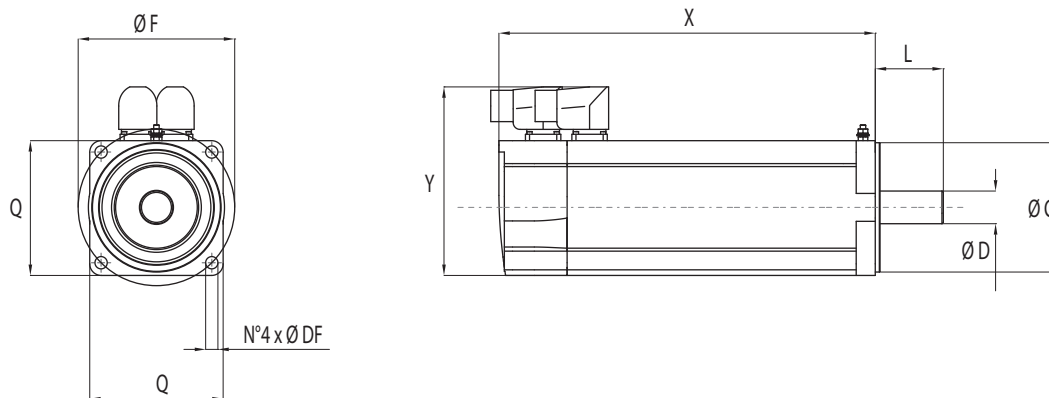

MOTORE MOTOR	D	L	C	F	DF	Q*	X**	Y**
MAA	9	20	40	63	5,5	55		
MBA	11	23	60	75	5,5	70		
MBB	11	23	60	90	5,8	75		
MBC	11	30	50	70	4,5	60		
MCA	14	30	60	75	5,5	70		
MCB	14	30	60	90	5,8	75		
MCC	14	30	80	100	6,5	92		
MCD	14	30	50	70	4,5	60		
MCE	14	30	60	75	6,5	72		
MCF	14	30	50	70	5,5	60		
MDA	19	40	95	115	9	105		
MDB	19	40	80	100	7	96		
MDC	19	35	70	90	6	80		
MDD	19	35	70	90	7	80		
MEA	24	50	95	115	9	100		
MEB	24	50	110	130	10	115		
MFA	16	40	80	100	7	90		
MFB	16	40	70	90	7	80		
MGA	10	32	80	100	6,6	90		

* Il valore "Q" è indicativo e varia a seconda della sigla e marca del motore. /
"Q" value is indicative and it depends on the motor type and brand.

** I valori "X" e "Y" variano a seconda della sigla e marca del motore. / "X" and
"Y" values depend on the motor type and brand.

MOTORE MOTOR	ESEMPIO DI MARCA E MODELLO BRAND AND TYPE EXAMPLE
MAA	SCHNEIDER (BSH/BMH 0551 / 0552 / 0553) SIEMENS (1FK7022) PARKER (SMB60.9X20) DANAHER (DBL2) OSAI (B28)
MBA	SCHNEIDER (BSH/BMH 0701 / 0702) PARKER (SMB60.11x23 / SMB82.11x23) OSAI (B36) LENZE (MCS06) SEW (CMP 50S M L BP)
MBB	DANAHER (DBL 3-11x23)
MBC	OMRON (R88M-K20030 11x23)
MCA	SCHNEIDER (BSH/BMH 0703) ELAU (ISH070-60-030) PARKER (SMB 82. 14x30)
MCB	DANAHER (DBL3. 14x30)
MCC	OSAI (B56) LENZE (MCS09) SEW (DFS 56)
MCD	OMRON (R88M-K20030 14x30)
MCE	SIEMENS (1FK7032 / 1FK7034)
MCF	DENSO (R2AA080)
MDA	SCHNEIDER (BSH/BMH 1001 / 1002 / 1003) PARKER (SMB82.19x40 / SMB100.19x40) DANAHER (DBL4) OSAI (B63) OMRON (R88M-K1K030)
MDB	SIEMENS (1FK 7040 / 1FK 7041)
MDC	OMRON (R88M.K75030)
MDD	DELTA ELECTRONICS (ECMA C0807) SIBONI (S 080 2B)
MEA	SCHNEIDER (BSH/BMH 1004) PARKER (SMB 100.24x50)
MEB	EMERSON - CONTROLTECHNIQUE 115 STOBER - EZ503U ALLEN-BRADLEY MPL-B4560
MFA	ALLEN-BRADLEY MPL-B 330P
MFB	DELTA ECMA C20807 YASKAWA SGMP H07
MGA	FANUC ALPHA IS2-5000

4.2

Riduttori epicicloidali Planetary gearboxes

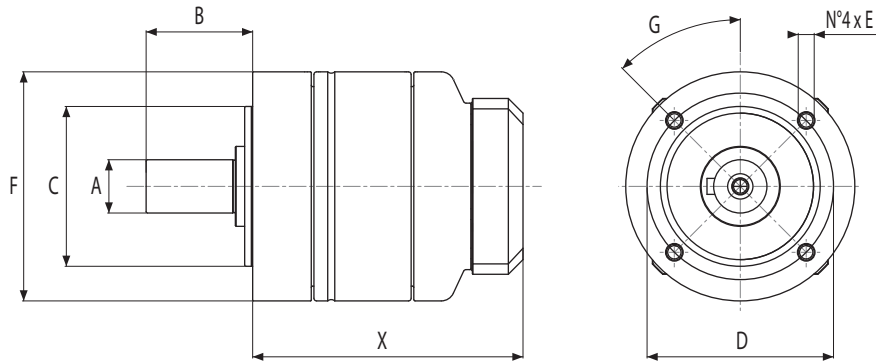

RIDUTTORE PLANETARY GEARBOX	A	B	C	D	E	F	G	X* 1 STAGE	X* 2 STAGES
GBA	12	24,5	35	44	M4	50	0°	66,5	93,5
GBB	14	35	40	52	M5	60	45°	90	123
GCA	16	36	52	62	M5	70	0°	81	107
GCB	20	40	60	70	M6	86	45°	115	154,5
GDA	22	46	68	80	M6	90	0°	97,5	132,5
GEA	32	70	90	108	M8	120	0°	116,5	155,5
GEB	25	55	80	100	M10	114	45°	149	202

* Il valore "X" varia a seconda della sigla della marca e del rapporto di riduzione del riduttore.
"X" value depends on the planetary gearbox type, brand and reduction ratio.

RIDUTTORE PLANETARY GEARBOX	ESEMPIO DI MARCA E MODELLO BRAND AND TYPE EXAMPLE
GBA	APEX (AE 050) WITTENSTEIN (LP 050) NEUGART (PLPE 050)
GBB	APEX (PGII 060) WITTENSTEIN (CP 060) NEUGART (PLE 060) SCHNEIDER (GBX 060)
GCA	APEX (AE 070) WITTENSTEIN (LP 070) NEUGART (PLPE 070)
GCB	APEX (PGII 080) WITTENSTEIN (CP 080) NEUGART (PLE 080) SCHNEIDER (GBX 080)
GDA	APEX (AE090) WITTENSTEIN (LP 090) NEUGART (PLPE 090)
GEA	APEX (AE 120) WITTENSTEIN (LP120) NEUGART (PLE 120)
GEB	APEX (PGII 120) WITTENSTEIN (CP 115) NEUGART (PLE 120) SCHNEIDER (GBX 120)

4.3 Rinvii angolari Angle bevel gearboxes

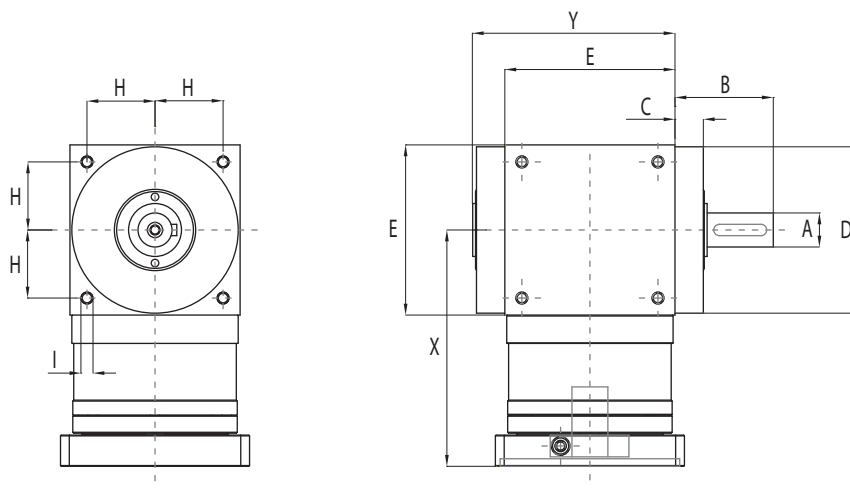

RINVIO ANGOLORE ANGLE BEVEL GEARBOX	A	B	C	D	E	H	I	X* 1 STAGE	X* 2 STAGES	Y
AAA	13	19,5	13	63	65	27	M4	101	129	80
ABA	16	30	14,5	73	75	30	M6	117	143,5	91,5
ACA	18	35	15	88	90	36	M6	125	165,5	107
ADA	22	40	15	108	110	44	M8	141,5	197	127
AEA	32	50	15	135	140	55	M10	175	234,5	157

* Il valore "X" varia a seconda della sigla della marca e del rapporto di riduzione del rinvio angolare.
"X" value depends on the bevel gearbox type, brand and reduction ratio.

RINVIO ANGOLORE ANGLE BEVEL GEARBOX	ESEMPIO DI MARCA E MODELLO BRAND AND TYPE EXAMPLE
AAA	APEX ATB065
ABA	APEX ATB075
ACA	APEX ATB090
ADA	APEX ATB110
AEA	APEX ATB140

5.

Grandezze 125 / 160 / 240

125 / 160 / 240 Sizes

IE 125	pg. 152
IE 160	pg. 162
IE 240	pg. 174

5.1

IE 125

5.1.1 Caratteristiche tecniche

5.1.1 Technical features

ISOMOVE IE 125		10	20
P	PASSO VITE SCREW LEAD [mm]	10	20
D	DIAMETRO VITE SCREW DIAMETER [mm]	63	50
F_d	CARICO MASSIMO DINAMICO APPLICABILE MAX ADMISSIBLE DYNAMIC LOAD [N]	80000*	80000*
C_{in,max}	PER AVERE $F_a = F_d$ TO GET [Nm]	141,5	283
	"CASO 1" / "CASE 1": B [Nm]	141,5	283
	"CASO 2" / "CASE 2": B+D / B+A [Nm]	$\left[\frac{157}{R} \right] + C_s$	$\left[\frac{314}{R} \right] + C_s$
		R = rapporto di riduzione del riduttore / rinvio angolare R = planetary / angle bevel gearbox reduction ratio	
C_{m,max}	"CASO 3" / "CASE 3": B+R (R00) [Nm]	157	314
		R = rapporto di riduzione della trasmissione a cinghia (disponibile R=1) R = belt gearbox reduction ratio (available R=1)	
	"CASO 4" / "CASE 4": B+R (R120) [Nm]	$\frac{174}{R}$	$\frac{349}{R}$
		R = rapporto di riduzione del riduttore epicicloidale R = planetary gearbox reduction ratio	
F_{st}	CARICO MASSIMO STATICO APPLICABILE MAX ADMISSIBLE STATIC LOAD [N]	100000	100000
V_{out,max}	VELOCITÀ DI TRASLAZIONE MASSIMA IN USCITA / ROTAZIONE MASSIMA VITE RDS [mm/sec]	265/1590	667/2000
N_{in,max}	MAX OUTPUT SPEED / MAX BALLSCREW ROTATING INPUT SPEED [rpm]		
a_{max}	ACCELERAZIONE MASSIMA IN USCITA MAX OUTPUT ACCELERATION [m/sec ²]	2	3
S_{max}	CORSA MASSIMA STANDARD MAX STANDARD STROKE [mm]	1200**	1200**
	PESO MODULO BASE CORSA 0 mm / PESO OGNI 100 mm DI CORSA BASIC MODULE WEIGHT FOR 0 mm STROKE / WEIGHT FOR ADDITIONAL 100 mm STROKE [Kg]	15 / 5,3	14 / 4,8
G_{s,max}	GIOCO ASSIALE MASSIMO PER CHIOCCIOLA STANDARD MAX AXIAL BACKLASH FOR STANDARD BALLSCREW ASSEMBLY mm	0,06	0,06
G_z	GIOCO "0" DELLA CHIOCCIOLA "0" BACKLASH BALLSCREW ASSEMBLY	A RICHIESTA / UPON REQUEST	
L_{10,Km}	DURATA LIFETIME Km	VEDI TABELLA / SEE TABLE pg. 154	

* Per le versioni R00/R01 controllare con i grafici delle pagina 156. / For R00/R01 types please check graph at page 156.

** Per corse superiori, contattare il nostro servizio tecnico. / For longer strokes please contact our technical dept.

ISOMOVE IE 125		10	20
VERSIONI DISPONIBILI AVAILABLE TYPES		R00 / R120 / A110 / A140 / D-R120 / D-R155	
$F_{a,p}$	POSSIBILE CON IL RIDUTTORE EPICICLOIDALE INDICATO POSSIBLE VALUE WITH THE INDICATED PLANETARY GEARBOX	[N] AE120/80000 AE155/80000	AE120/45000*** AE155/75200***
	POSSIBILE CON IL RINVIO ANGOLARE INDICATO POSSIBLE VALUE WITH THE INDICATED ANGLE BEVEL GEARBOX	[N] ATB110/37400*** ATB140/80000	ATB110/18600*** ATB140/43000***
ACCESSORI DISPONIBILI AVAILABLE ACCESSORIES		NON DISPONIBILE / NOT AVAILABLE	

*** È il valore massimo ottenibile con il rapporto di riduzione disponibile avente il minore valore di coppia erogabile.
It is the max obtainable value with the available on tables reduction ratio which has the lowest value of nominal output torque.

RIDUTTORI-RINVII "STANDARD SETEC GROUP DISPONIBILI"
"STANDARD SETEC GROUP AVAILABLE" PLANETARY-ANGLE BEVEL GEARBOXES

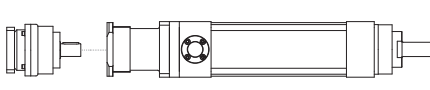
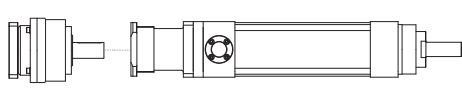
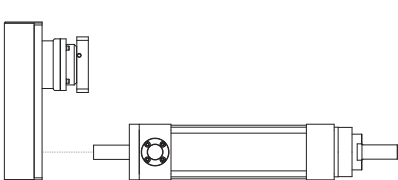
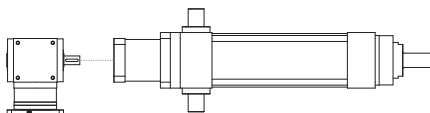
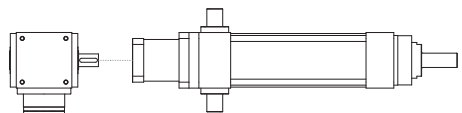
<p>TRASMISSIONE COASSIALE CON RIDUTTORE</p> <p>IN-LINE PLANETARY GEARBOX STAGE</p> <p>B+D</p>	 <p>AE120 MODULO BASE BASIC MODULE</p>  <p>AE155 MODULO BASE BASIC MODULE</p>
<p>TRASMISSIONE PARALLELA CON RIDUTTORE</p> <p>PARALLEL BELT GEARBOX STAGE + IN-LINE PLANETARY GEARBOX REDUCTION STAGE</p> <p>B+R</p>	 <p>AE120 MODULO BASE BASIC MODULE</p>
<p>TRASMISSIONE ANGOLARE CON RINVIO</p> <p>ANGLE BEVEL GEARBOX STAGE</p> <p>B+A</p>	 <p>ATB110 MODULO BASE BASIC MODULE</p>  <p>ATB140 MODULO BASE BASIC MODULE</p>

5.1.2 Calcolo durata

5.1.2 Lifetime calculation

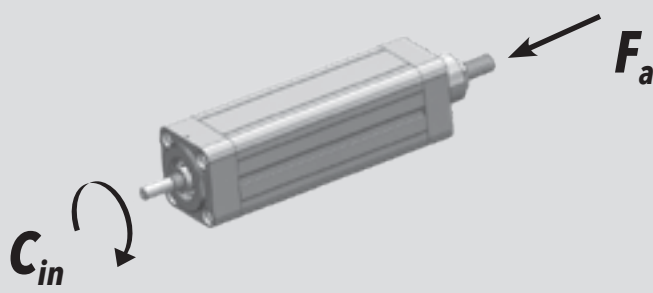

IE 125 P = 10 mm	$L_{10,Km} = \left[\frac{107400}{F_{eq}} \right]^3 \cdot 10$	$L_{10,Km} = [Km]$ $F_{eq} = [N]$
IE 125 P = 20 mm	$L_{10,Km} = \left[\frac{84000}{F_{eq}} \right]^3 \cdot 20$	$L_{10,Km} = [Km]$ $F_{eq} = [N]$

5.1.3 Calcolo coppia in ingresso
al modulo base5.1.3 Torque calculation at basic
module input shaft

		
IE 125 P = 10 mm	$C_{in} = \left[\frac{F_a \cdot 10}{5652} \right]$	$C_{in} = [Nm]$ $F_a = [N]$
IE 125 P = 20 mm	$C_{in} = \left[\frac{F_a \cdot 20}{5652} \right]$	$C_{in} = [Nm]$ $F_a = [N]$

5.1.4 Calcolo coppia motore

5.1.4 Motor torque calculation

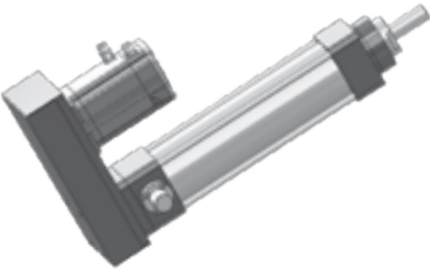
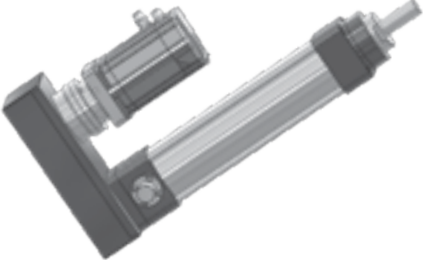
<p>CASO / CASE 1</p>	<p style="text-align: center;">ISOMOVE B</p>  $C_m = C_{in} \quad [Nm]$
<p>CASO / CASE 2</p>	<p style="text-align: center;">ISOMOVE B+D / B+A</p>  $C_m = \left[\frac{C_{in}}{R \cdot \eta} \right] + C_s \quad [Nm]$ <p><i>R</i> = rapporto di riduzione riduttore / rinvio planetary / angle bevel gearbox reduction ratio <i>η</i> = rendimento meccanico / mechanical efficiency = 0,90</p>
<p>CASO / CASE 3</p>	<p style="text-align: center;">ISOMOVE B+R (R00)</p>  $C_m = \left[\frac{C_{in}}{R \cdot \eta} \right] \quad [Nm]$ <p><i>R</i> = rapporto di riduzione trasmissione a cinghia, disponibile R=1 belt gearbox reduction ratio, available R=1 <i>η</i> = rendimento meccanico / mechanical efficiency = 0,90</p>
<p>CASO / CASE 4</p>	<p style="text-align: center;">ISOMOVE B+R (R120)</p>  $C_m = \left[\frac{C_{in}}{R \cdot \eta} \right] + C_s \quad [Nm]$ <p><i>R</i> = rapporto di riduzione riduttore epicicloidale planetary gearbox reduction ratio <i>η</i> = rendimento meccanico / mechanical efficiency = 0,81</p>

5.1.5 Potenza in ingresso alla trasmissione a cinghia (versione R)

5.1.5 Mechanical input power at belt gear stage (R type)

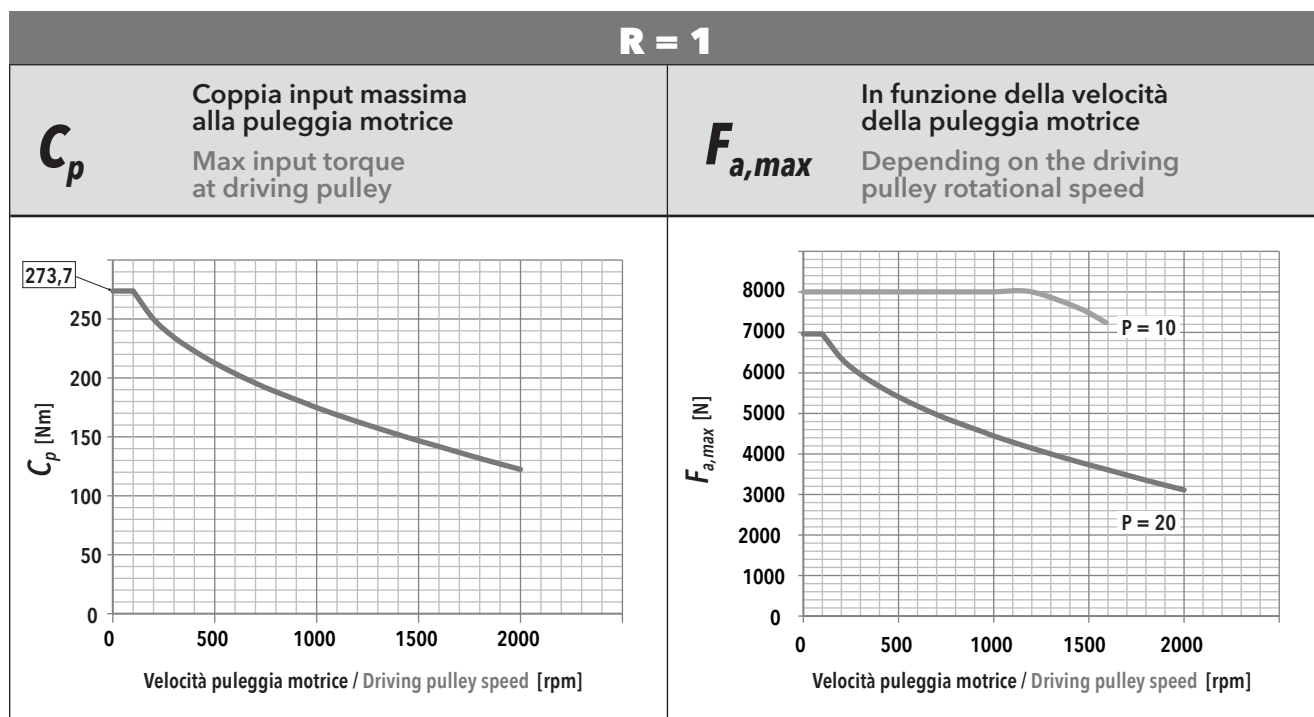

F_r Forza radiale su asse puleggia motrice in funzione di C_{in}
Radial force on driving pulley as a function of C_{in}

f_t Frequenza di vibrazione della cinghia per il tensionamento (al montaggio)
Vibration frequency of the belt for its tensioning (during assembly)

IE 125 - PASSO / PITCH 10					
F_a [N]		V_{out} [mm/s]			
		26,5	106	185,5	265
80000	F_r [N]	2547	2561	2591	
	f_t [Hz]	120	121	121	
72000	F_r [N]	2292	2306	2337	2384
	f_t [Hz]	114	114	115	116
64000	F_r [N]	2038	2052	2082	2129
	f_t [Hz]	108	108	109	110
56000	F_r [N]	1783	1797	1827	1875
	f_t [Hz]	101	101	102	103
48000	F_r [N]	1529	1542	1573	1620
	f_t [Hz]	93	94	95	96
40000	F_r [N]	1274	1288	1318	1365
	f_t [Hz]	85	86	87	88
32000	F_r [N]	1019	1033	1063	1111
	f_t [Hz]	76	77	78	79
24000	F_r [N]	765	779	809	856
	f_t [Hz]	66	67	68	70
16000	F_r [N]	510	524	554	602
	f_t [Hz]	54	55	56	58
8000	F_r [N]	255	269	300	347
	f_t [Hz]	38	39	41	44

IE 125 - PASSO / PITCH 20					
F_a [N]		V_{out} [mm/s]			
		66,7	266,8	466,9	667
80000	F_r [N]				
	f_t [Hz]				
72000	F_r [N]				
	f_t [Hz]				
64000	F_r [N]	4075			
	f_t [Hz]	152			
56000	F_r [N]	3566			
	f_t [Hz]	142			
48000	F_r [N]	3057	3079		
	f_t [Hz]	132	132		
40000	F_r [N]	2548	2569		
	f_t [Hz]	120	121		
32000	F_r [N]	2038	2060	2108	
	f_t [Hz]	108	108	109	
24000	F_r [N]	1529	1551	1599	
	f_t [Hz]	93	94	95	
16000	F_r [N]	1020	1042	1090	1165
	f_t [Hz]	76	77	79	81
8000	F_r [N]	656	532	581	656
	f_t [Hz]	61	55	57	61

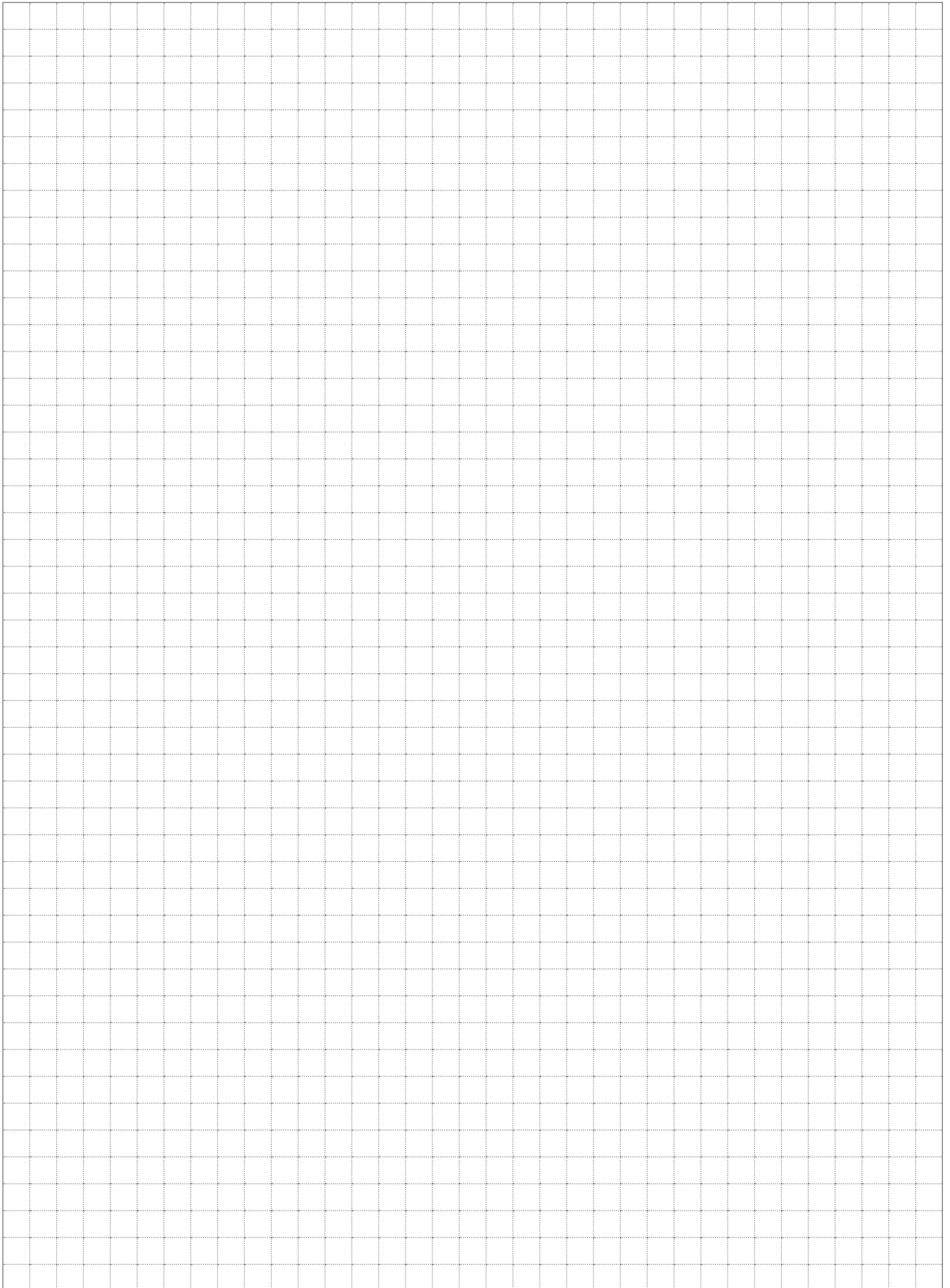

5.1.6 Caratteristiche dimensionali

5.1.6 Overall dimensions

B
MODULO BASE
BASIC MODULE

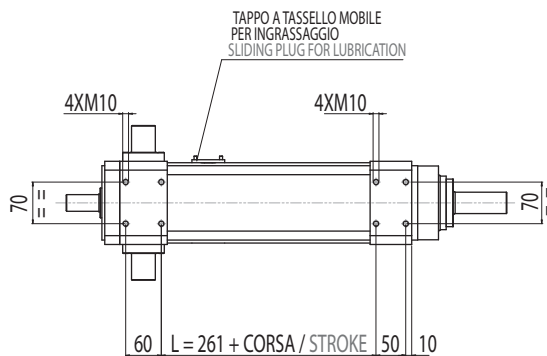
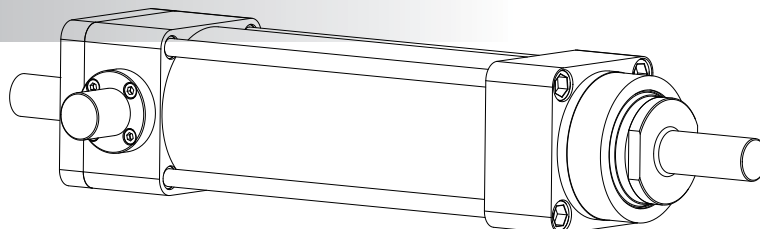

Per fissare la flangia indicata, rimuovere le 4 viti M12 (1) ed utilizzare le 4 filettature (2)
To assembly the flange indicated, unscrew the 4 screws M12 (1) and use the 4 screws (2)

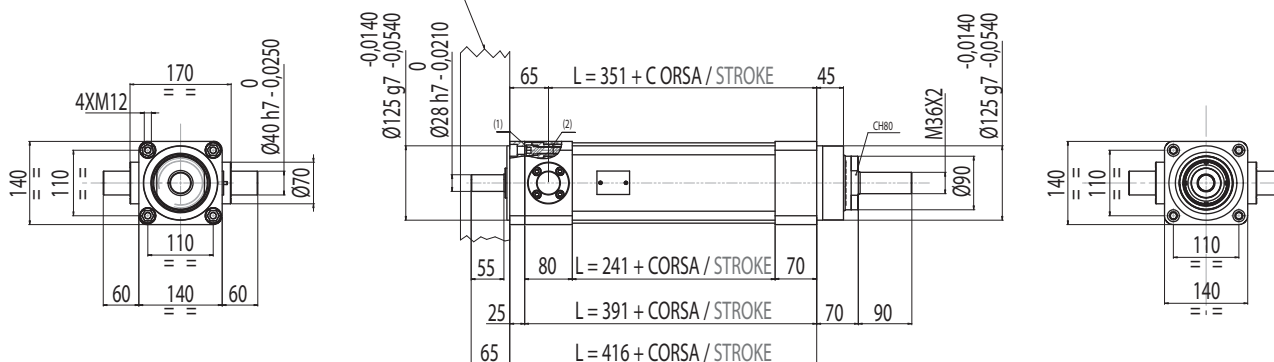

B+D

MODULO BASE + RIDUTTORE EPICICLOIDALE COASSIALE

BASIC MODULE + IN-LINE PLANETARY GEARBOX REDUCTION STAGE

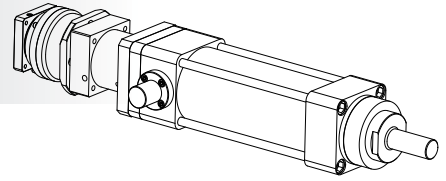

R120

(AE 120)

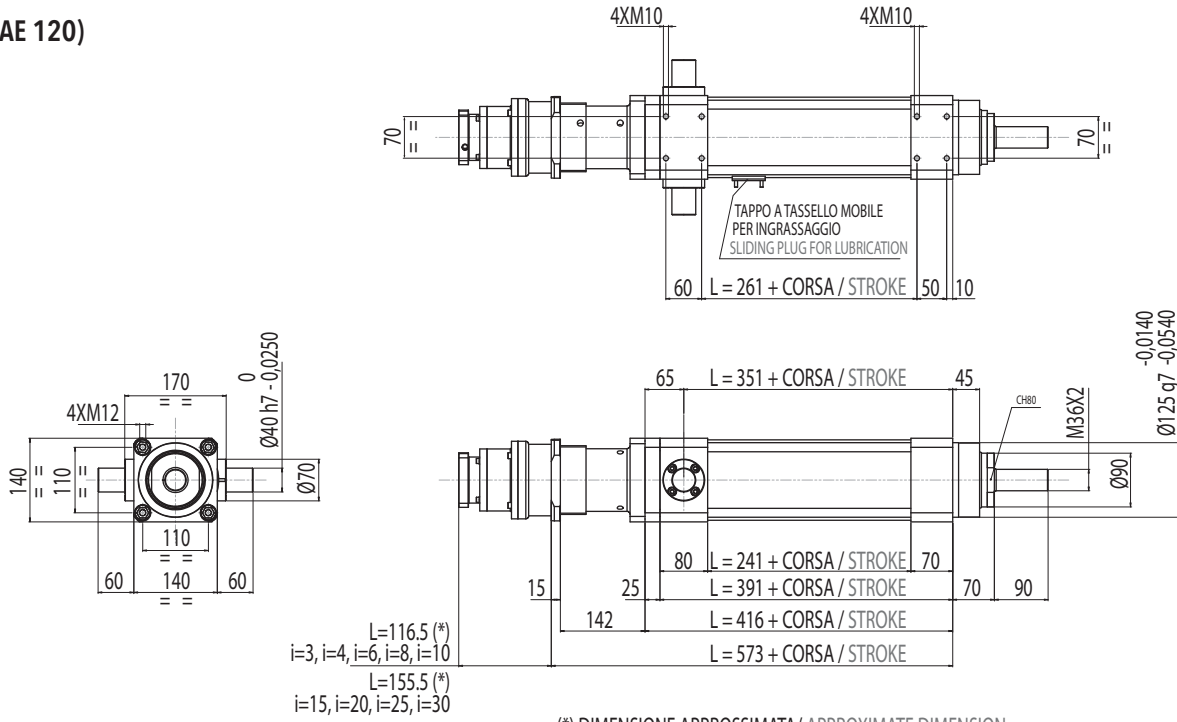

(*) DIMENSIONE APPROSSIMATA/ APPROXIMATE DIMENSION

R155

(AE 155)

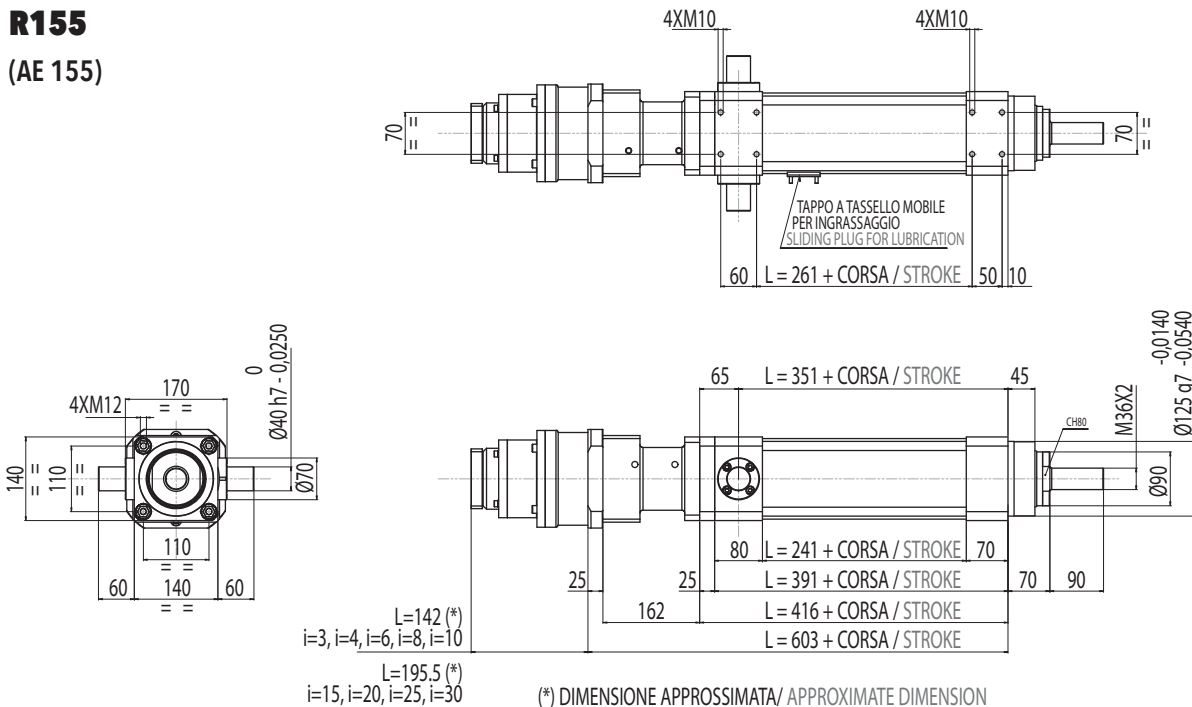

(*) DIMENSIONE APPROSSIMATA/ APPROXIMATE DIMENSION

B+A
MODULO BASE + RINVIO ANGOLARE
BASIC MODULE + ANGLE BEVEL GEARBOX STAGE

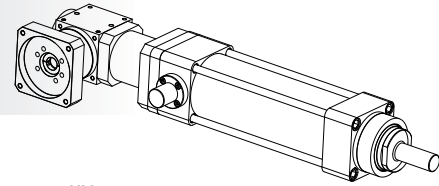

A110
(ATB110-FL1)

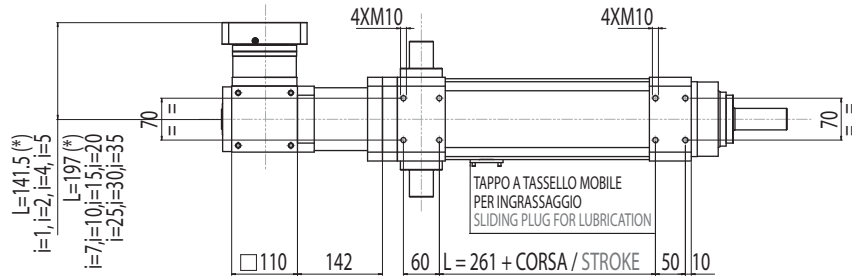

(*) DIMENSIONE APPROSSIMATA/ APPROXIMATE DIMENSION

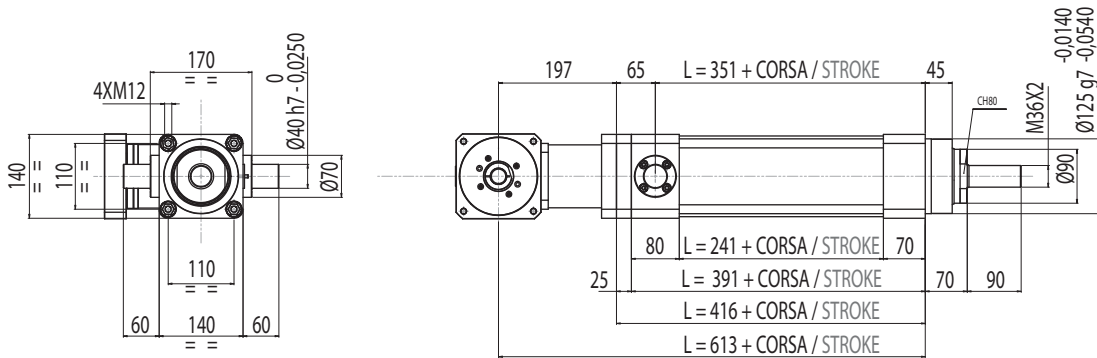

A140
(ATB140-FL1)

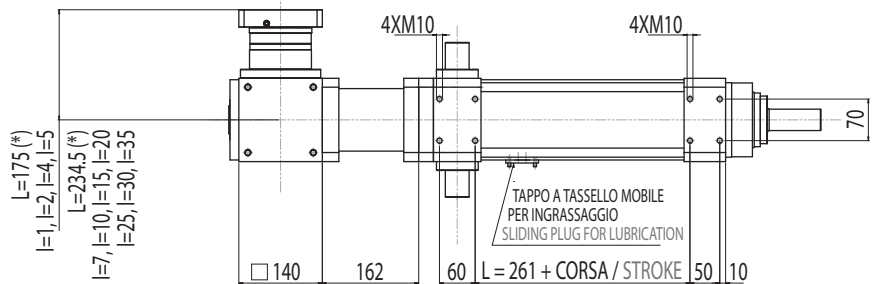

(*) DIMENSIONE APPROSSIMATA/ APPROXIMATE DIMENSION

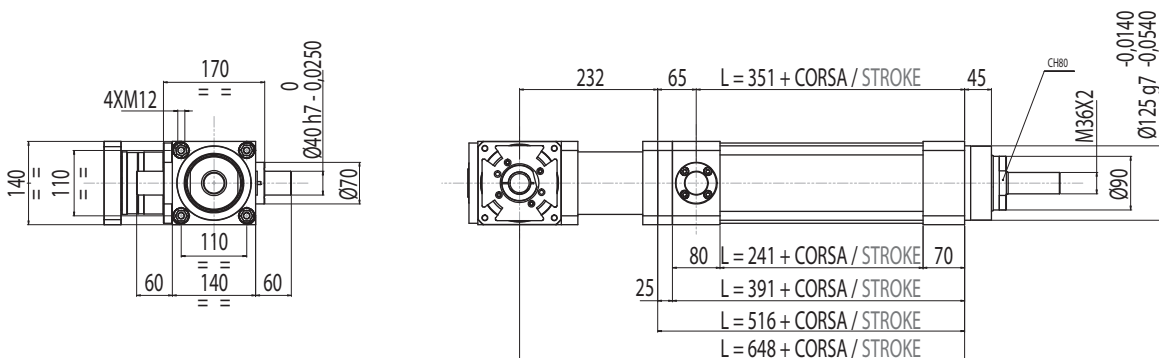

B+R

MODULO BASE + TRASMISSIONE A CINGHIA IN PARALLELO
PER MOTORE CUSTOM

BASIC MODULE + PARALLEL FOR CUSTOM MOTORS BELT GEARBOX STAGE

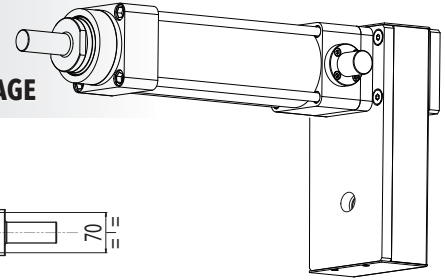

R00

R=1
CINGHIA / BELT

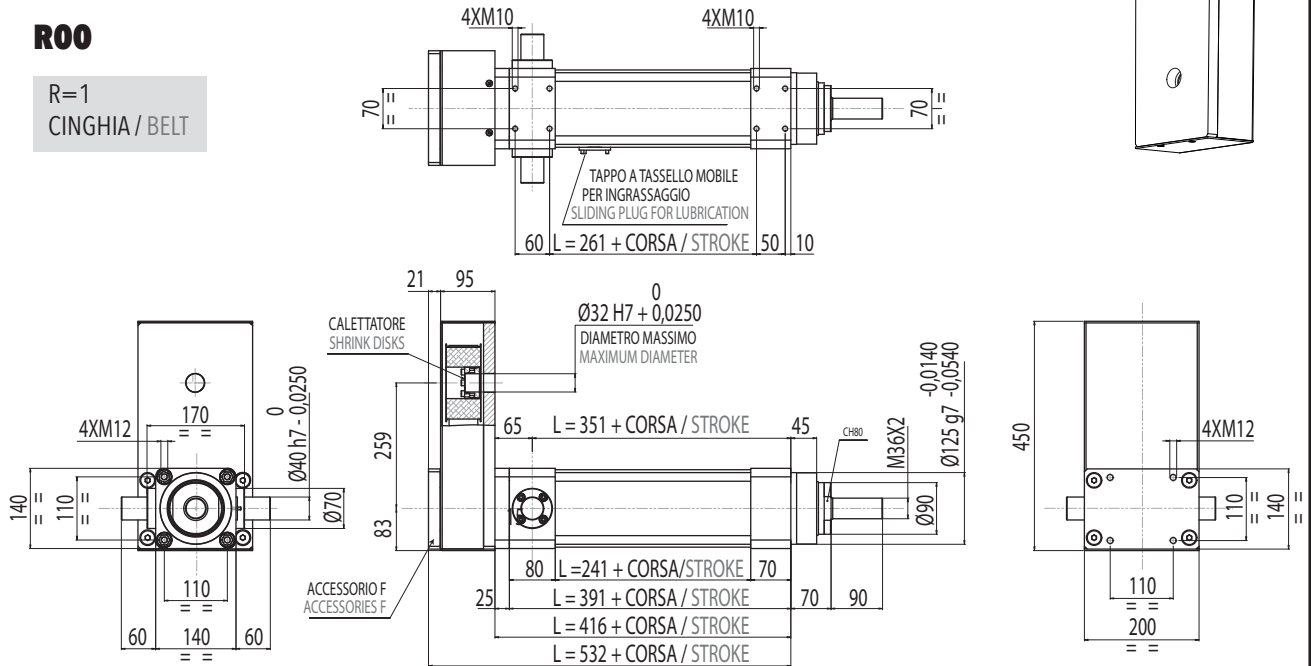

B+R

MODULO BASE + TRASMISSIONE A CINGHIA IN PARALLELO
+ RIDUTTORE EPICICLOIDALE R120

BASIC MODULE + PARALLEL BELT GEARBOX STAGE
+ IN-LINE PLANETARY GEARBOX REDUCTION STAGE R120

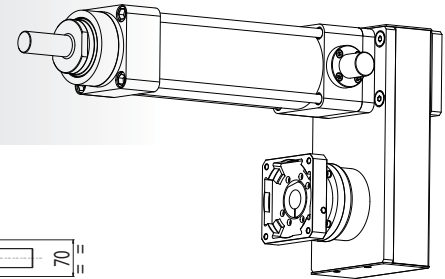

R120

(AE 120)

R=1
CINGHIA / BELT

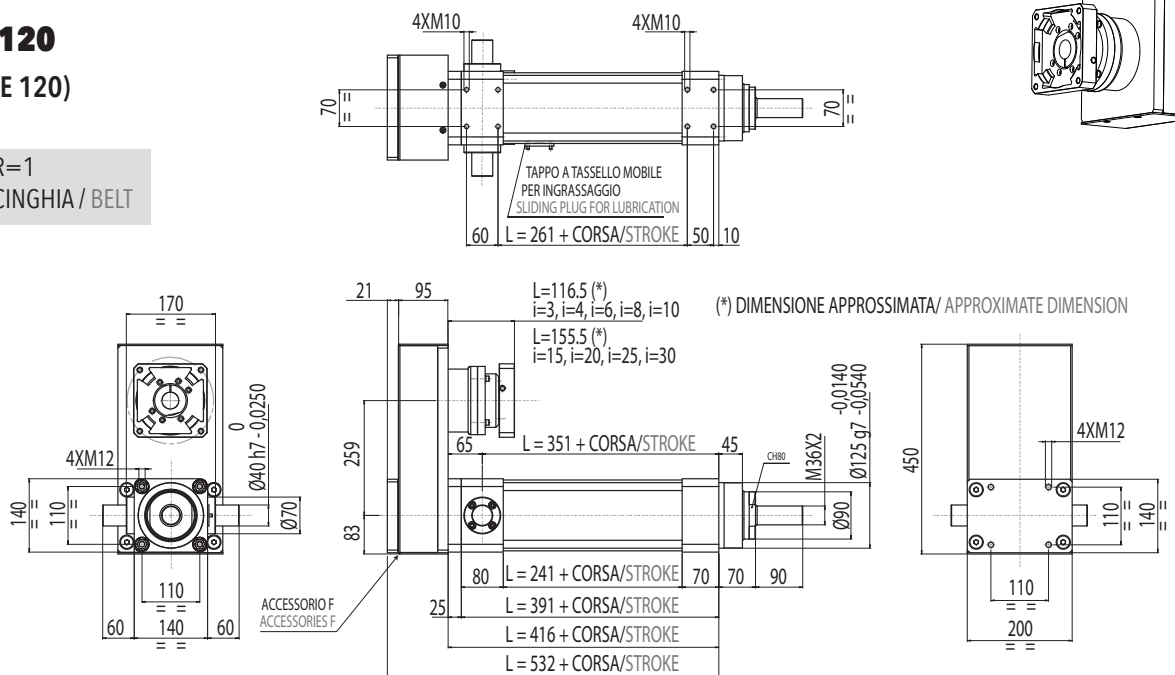

5.2

IE 160

5.2.1 Caratteristiche tecniche

5.2.1 Technical features

ISOMOVE IE 160		10	20
P	PASSO VITE SCREW LEAD [mm]	10	20
D	DIAMETRO VITE SCREW DIAMETER [mm]	80	80
F_d	CARICO MASSIMO DINAMICO APPLICABILE MAX ADMISSIBLE DYNAMIC LOAD [N]	100.000*	120.000*
C_{in,max}	PER AVERE $F_a = F_d$ TO GET [Nm]	177	424
	"CASO 1" / "CASE 1": B [Nm]	177	424
	"CASO 2" / "CASE 2": B+D / B+A [Nm]	$\left[\frac{197}{R} \right] + C_s$	$\left[\frac{471}{R} \right] + C_s$
		R = rapporto di riduzione del riduttore / rinvio angolare R = planetary / angle bevel gearbox reduction ratio	
C_{m,max}	"CASO 3" / "CASE 3": B+R (R00) [Nm]	197	471
		R = rapporto di riduzione della trasmissione a cinghia (disponibile R=1) R = belt gearbox reduction ratio (available R=1)	
	"CASO 4" / "CASE 4": B+R (R120 / R155) [Nm]	$\frac{218}{R}$	$\frac{523}{R}$
		R = rapporto di riduzione del riduttore epicicloidale R = planetary gearbox reduction ratio	
F_{st}	CARICO MASSIMO STATICO APPLICABILE MAX ADMISSIBLE STATIC LOAD [N]	160.000	160.000
V_{out,max}	VELOCITÀ DI TRASLAZIONE MASSIMA IN USCITA / ROTAZIONE MASSIMA VITE RDS [mm/sec]	208/1248	417/1251
N_{in,max}	MAX OUTPUT SPEED / MAX BALLSCREW ROTATING INPUT SPEED [rpm]		
a_{max}	ACCELERAZIONE MASSIMA IN USCITA MAX OUTPUT ACCELERATION [m/sec ²]	2	3
S_{max}	CORSA MASSIMA STANDARD MAX STANDARD STROKE [mm]	1200**	1200**
	PESO MODULO BASE CORSA 0 mm / PESO OGNI 100 mm DI CORSA BASIC MODULE WEIGHT FOR 0 mm STROKE / WEIGHT FOR ADDITIONAL 100 mm STROKE [Kg]	19,5 / 7	19,5 / 7
G_{s,max}	GIOCO ASSIALE MASSIMO PER CHIOCCIOLA STANDARD MAX AXIAL BACKLASH FOR STANDARD BALLSCREW ASSEMBLY mm	0,06	0,06
G_z	GIOCO "0" DELLA CHIOCCIOLA "0" BACKLASH BALLSCREW ASSEMBLY	NON DISPONIBILE / NOT AVAILABLE	
L_{10,Km}	DURATA LIFETIME Km	VEDI TABELLA / SEE TABLE pg. 164	

* Per le versioni R00/R01 controllare con i grafici della pagina 166. / For R00/R01 types please check graph at page 166.

** Per corse superiori, contattare il nostro servizio tecnico. / For longer strokes please contact our technical dpt.

ISOMOVE IE 160		5	20	
VERSIONI DISPONIBILI AVAILABLE TYPES		R00 / R120 / R155 / A140 / A170 / A210 / D-R120 / D-R155		
$F_{a,p}$	POSSIBILE CON IL RIDUTTORE EPICICLOIDALE INDICATO POSSIBLE VALUE WITH THE INDICATED PLANETARY GEARBOX	[N]	AE120/91000*** AE155/100000	AE120/45000*** AE155/75200***
	POSSIBILE CON IL RINVIO ANGOLARE INDICATO POSSIBLE VALUE WITH THE INDICATED ANGLE BEVEL GEARBOX	[N]	ATB140/86000*** ATB170/100000 ATB210/100000	ATB140/43000*** ATB170/68600*** ATB210/100000
ACCESSORI DISPONIBILI AVAILABLE ACCESSORIES		NON DISPONIBILE / NOT AVAILABLE		

*** È il valore massimo ottenibile con il rapporto di riduzione disponibile avente il minore valore di coppia erogabile.
It is the max obtainable value with the available on tables reduction ratio which has the lowest value of nominal output torque.

RIDUTTORI-RINVII "STANDARD SETEC GROUP DISPONIBILI"
"STANDARD SETEC GROUP AVAILABLE" PLANETARY-ANGLE BEVEL GEARBOXES

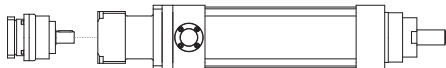
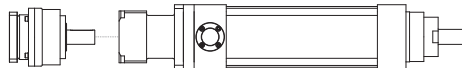
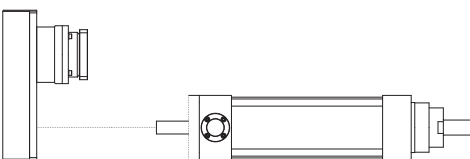
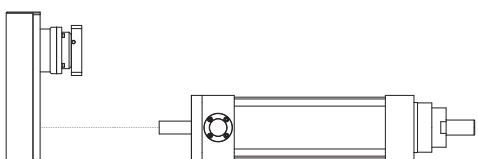
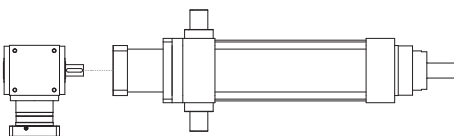
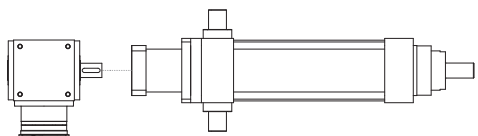
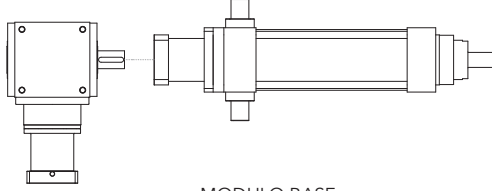
<p>TRASMISSIONE COASSIALE CON RIDUTTORE</p> <p>IN-LINE PLANETARY GEARBOX STAGE</p> <p>B+D</p>	 <p>AE120</p> <p>MODULO BASE BASIC MODULE</p>	 <p>AE155</p> <p>MODULO BASE BASIC MODULE</p>
<p>TRASMISSIONE PARALLELA CON RIDUTTORE</p> <p>PARALLEL BELT GEARBOX STAGE + IN-LINE PLANETARY GEARBOX REDUCTION STAGE</p> <p>B+R</p>	 <p>AE155</p> <p>MODULO BASE BASIC MODULE</p>	 <p>AE120</p> <p>MODULO BASE BASIC MODULE</p>
<p>TRASMISSIONE ANGOLARE CON RINVIO</p> <p>ANGLE BEVEL GEARBOX STAGE</p> <p>B+A</p>	 <p>ATB140</p> <p>MODULO BASE BASIC MODULE</p>	 <p>ATB170</p> <p>MODULO BASE BASIC MODULE</p>
	 <p>ATB210</p> <p>MODULO BASE BASIC MODULE</p>	

5.2.2 Calcolo durata

5.2.2 Lifetime calculation

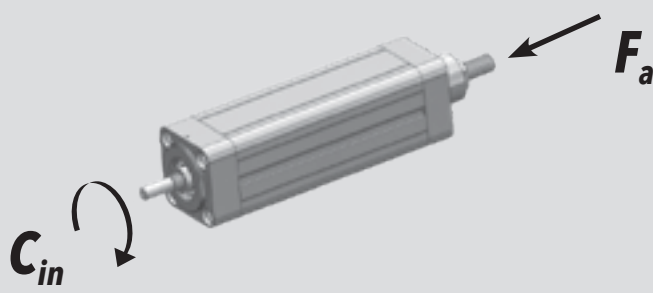

IE 160 P = 10 mm	$L_{10,Km} = \left[\frac{123800}{F_{eq}} \right]^3 \cdot 10$	$L_{10,Km} = [Km]$ $F_{eq} = [N]$
IE 160 P = 20 mm	$L_{10,Km} = \left[\frac{174000}{F_{eq}} \right]^3 \cdot 20$	$L_{10,Km} = [Km]$ $F_{eq} = [N]$

5.2.3 Calcolo coppia in ingresso
al modulo base5.2.3 Torque calculation at basic
module input shaft

		
IE 160 P = 10 mm	$C_{in} = \left[\frac{F_a \cdot 10}{5652} \right]$	$C_{in} = [Nm]$ $F_a = [N]$
IE 160 P = 20 mm	$C_{in} = \left[\frac{F_a \cdot 20}{5652} \right]$	$C_{in} = [Nm]$ $F_a = [N]$

5.2.4 Calcolo coppia motore

5.2.4 Motor torque calculation

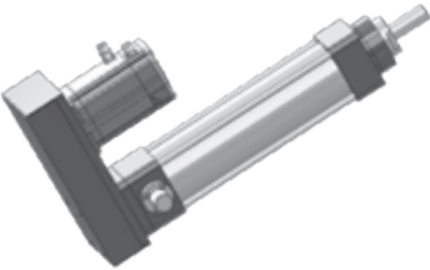
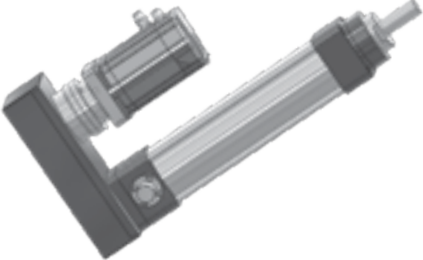
<p>CASO / CASE 1</p>	<p style="text-align: center;">ISOMOVE B</p>  $C_m = C_{in} \quad [Nm]$
<p>CASO / CASE 2</p>	<p style="text-align: center;">ISOMOVE B+D / B+A</p>  $C_m = \left[\frac{C_{in}}{R \cdot \eta} \right] + C_s \quad [Nm]$ <p><i>R</i> = rapporto di riduzione riduttore / rinvio planetary / angle bevel gearbox reduction ratio <i>η</i> = rendimento meccanico / mechanical efficiency = 0,90</p>
<p>CASO / CASE 3</p>	<p style="text-align: center;">ISOMOVE B+R (R00)</p>  $C_m = \left[\frac{C_{in}}{R \cdot \eta} \right] \quad [Nm]$ <p><i>R</i> = rapporto di riduzione trasmissione a cinghia, disponibile R=1 belt gearbox reduction ratio, available R=1 <i>η</i> = rendimento meccanico / mechanical efficiency = 0,90</p>
<p>CASO / CASE 4</p>	<p style="text-align: center;">ISOMOVE B+R (R120 / R155)</p>  $C_m = \left[\frac{C_{in}}{R \cdot \eta} \right] + C_s \quad [Nm]$ <p><i>R</i> = rapporto di riduzione riduttore epicicloidale planetary gearbox reduction ratio <i>η</i> = rendimento meccanico / mechanical efficiency = 0,81</p>

5.2.5 Potenza in ingresso alla trasmissione a cinghia (versione R)

5.2.5 Mechanical input power at belt gear stage (R type)

R = 1

C_p Coppia input massima alla puleggia motrice
Max input torque at driving pulley

$F_{a,max}$ In funzione della velocità della puleggia motrice
Depending on the driving pulley rotational speed

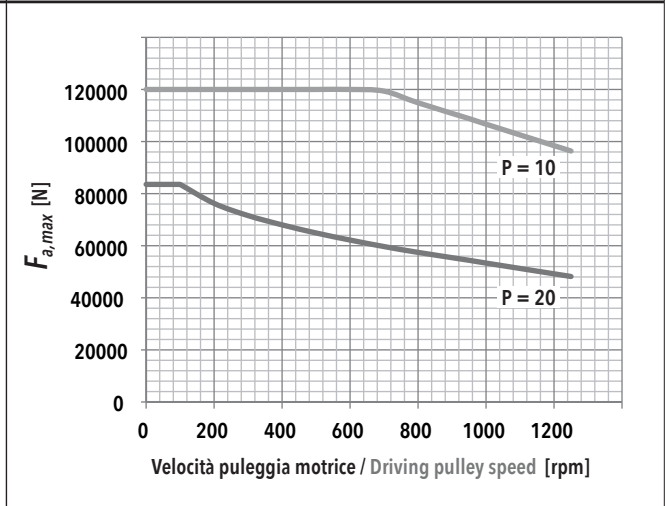
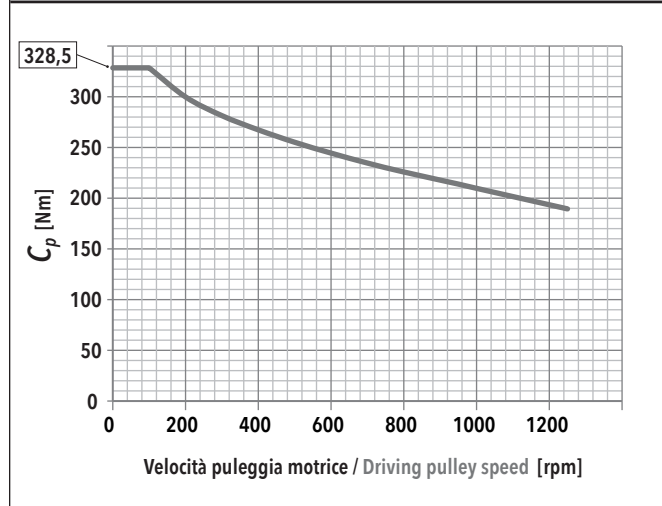

F_r Forza radiale su asse puleggia motrice in funzione di C_{in}
Radial force on driving pulley as a function of C_{in}

f_t Frequenza di vibrazione della cinghia per il tensionamento (al montaggio)
Vibration frequency of the belt for its tensioning (during assembly)

IE 160 - PASSO / PITCH 10					
F_a [N]		V_{out} [mm/s]			
		20,8	83,2	145,6	208
100000	F_r [N]	3183	3192	3210	
	f_t [Hz]	134	135	135	
90000	F_r [N]	2865	2873	2892	2921
	f_t [Hz]	128	128	128	129
80000	F_r [N]	2547	2555	2574	2603
	f_t [Hz]	120	120	121	122
70000	F_r [N]	2228	2237	2255	2285
	f_t [Hz]	113	113	113	114
60000	F_r [N]	1910	1919	1937	1966
	f_t [Hz]	104	104	105	106
50000	F_r [N]	1592	1600	1619	1648
	f_t [Hz]	95	95	96	97
40000	F_r [N]	1274	1282	1301	1330
	f_t [Hz]	85	85	86	87
30000	F_r [N]	955	964	982	1012
	f_t [Hz]	74	74	75	76
20000	F_r [N]	637	646	664	693
	f_t [Hz]	60	61	61	63
10000	F_r [N]	319	327	346	375
	f_t [Hz]	43	43	44	46

IE 160 - PASSO / PITCH 20					
F_a [N]		V_{out} [mm/s]			
		41,7	166,8	291,9	417
120000	F_r [N]				
	f_t [Hz]				
108000	F_r [N]				
	f_t [Hz]				
96000	F_r [N]				
	f_t [Hz]				
84000	F_r [N]	5347			
	f_t [Hz]	174			
72000	F_r [N]	4583			
	f_t [Hz]	161			
60000	F_r [N]	3820	3828		
	f_t [Hz]	147	147		
48000	F_r [N]	3056	3064	3083	
	f_t [Hz]	132	132	132	
36000	F_r [N]	2292	2301	2320	2349
	f_t [Hz]	114	114	115	116
24000	F_r [N]	1528	1537	1556	1585
	f_t [Hz]	93	93	94	95
12000	F_r [N]	764	773	792	821
	f_t [Hz]	66	66	67	68

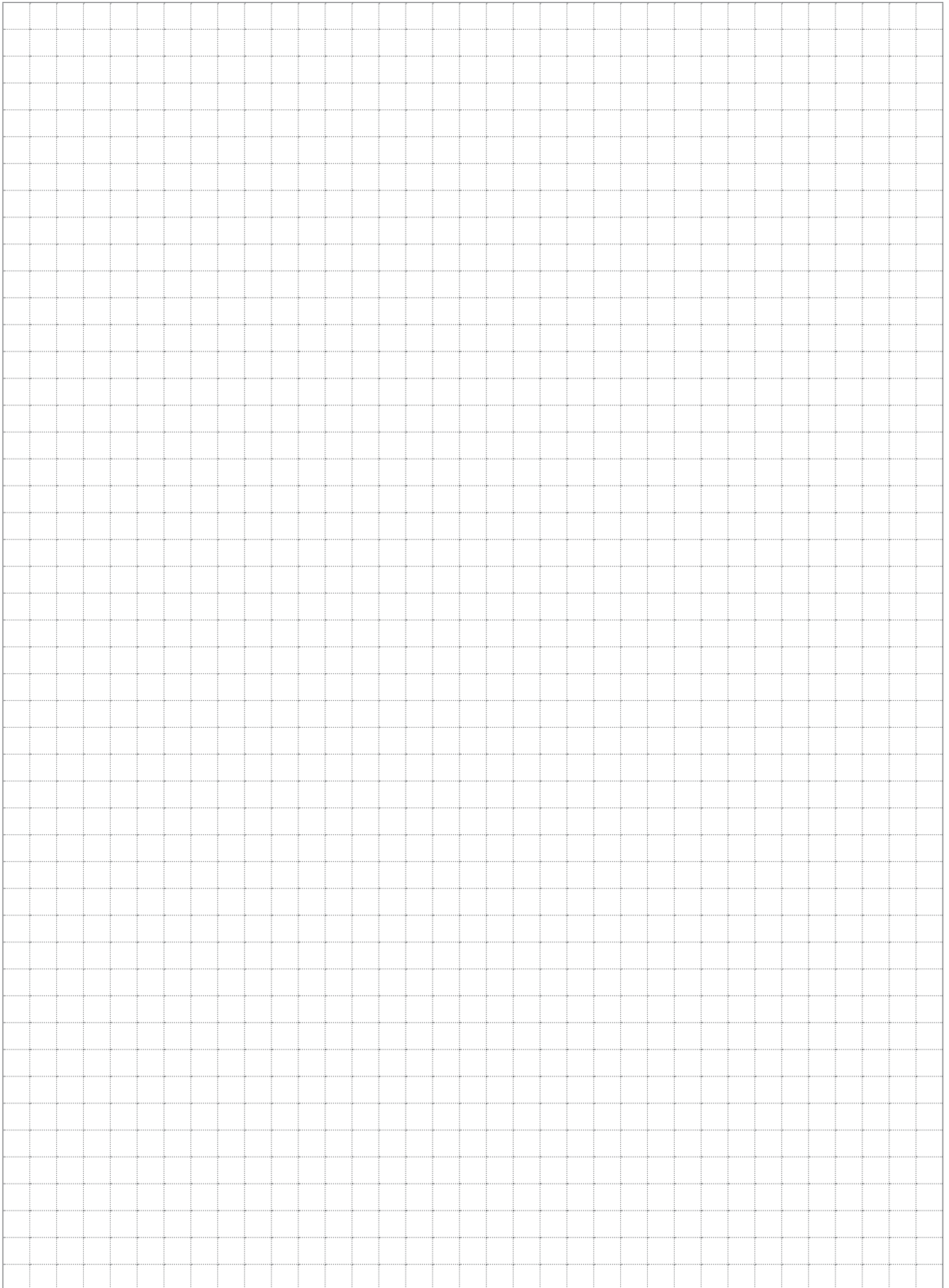

5.2.6 Caratteristiche dimensionali

5.2.6 Overall dimensions

B
MODULO BASE
BASIC MODULE

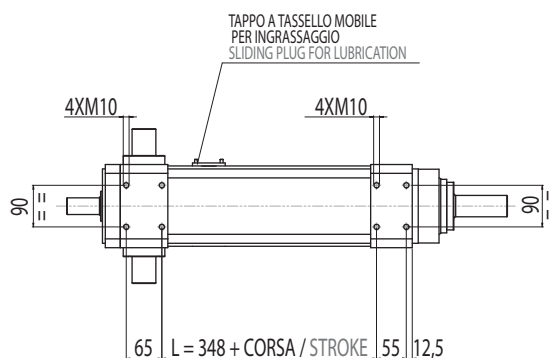
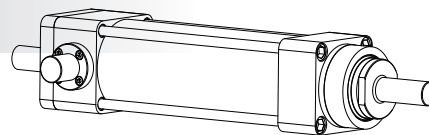

Per fissare la flangia indicata, rimuovere le 4 viti M12 (1) ed utilizzare le 4 filettature (2)
To assembly the flange indicated, unscrew the 4 screws M12 (1) and use the 4 screws (2)

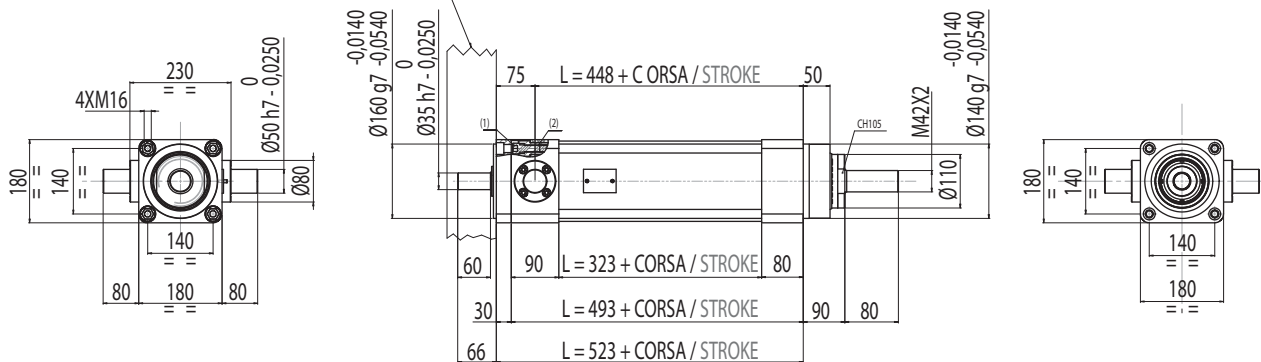

B+D

MODULO BASE + RIDUTTORE EPICICLOIDALE COASSIALE

BASIC MODULE + IN-LINE PLANETARY GEARBOX REDUCTION STAGE

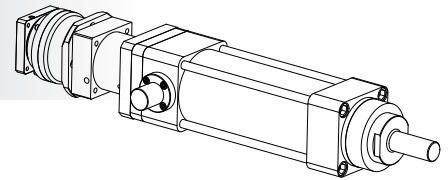

R120

(AE 120)

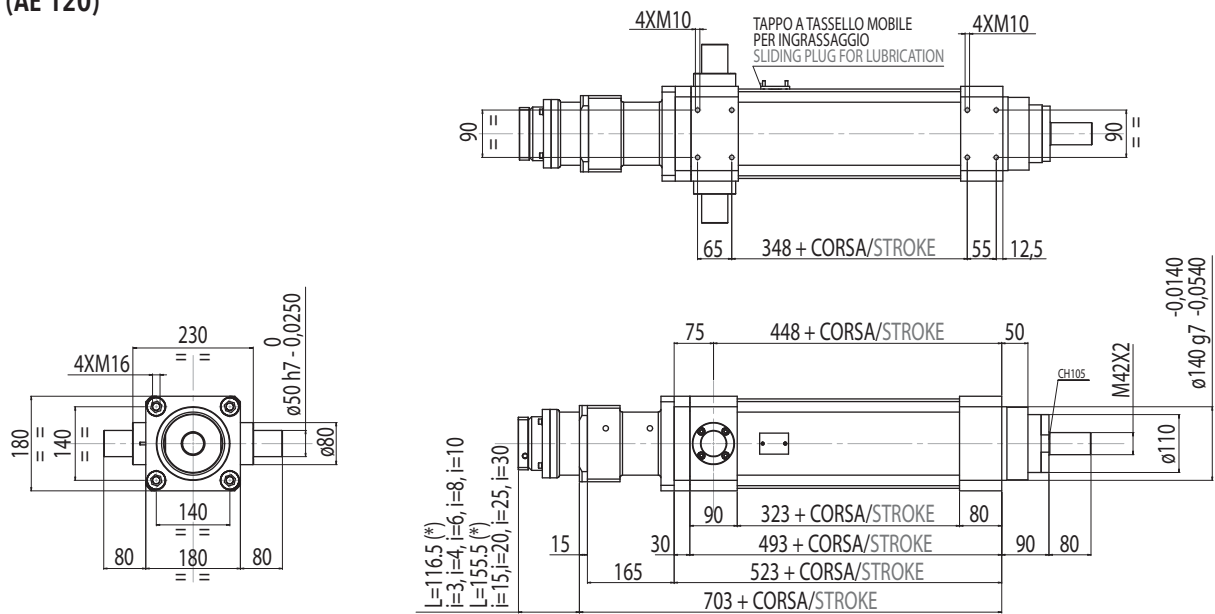

(*) DIMENSIONE APPROSSIMATA / APPROXIMATE DIMENSION

R155

(AE 155)

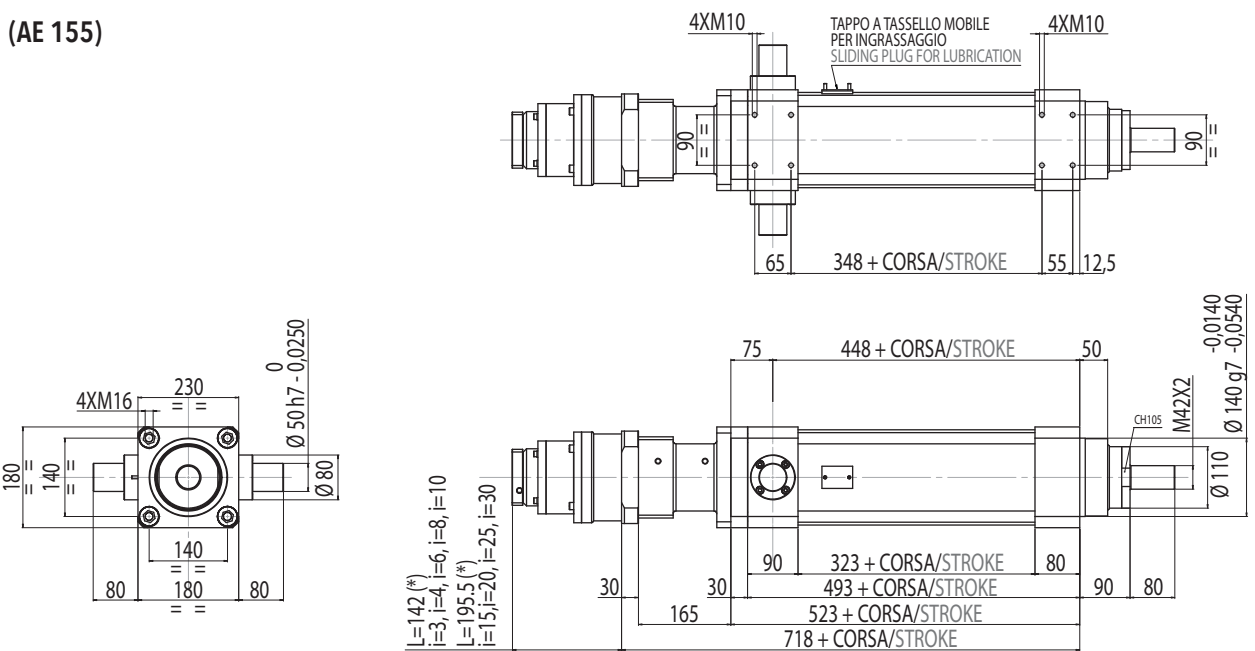

(*) DIMENSIONE APPROSSIMATA / APPROXIMATE DIMENSION

B+A

MODULO BASE + RINVIO ANGOLARE

BASIC MODULE + ANGLE BEVEL GEARBOX STAGE

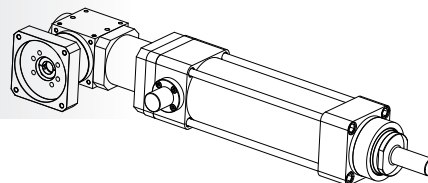

A140

(ATB140-FL1)

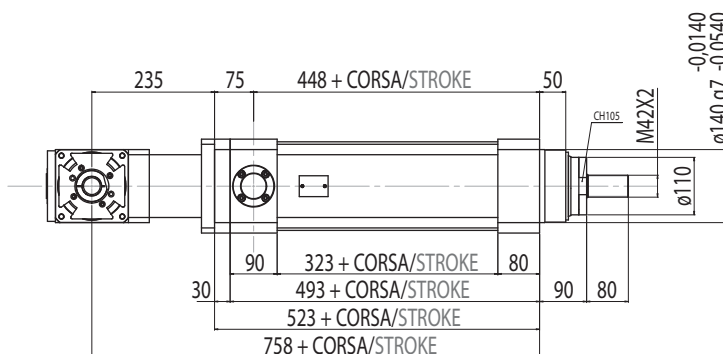
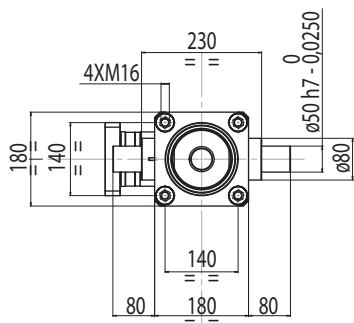
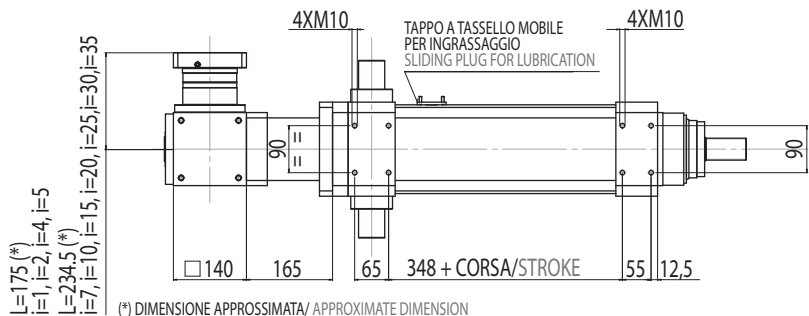

A170

(ATB170-FL1)

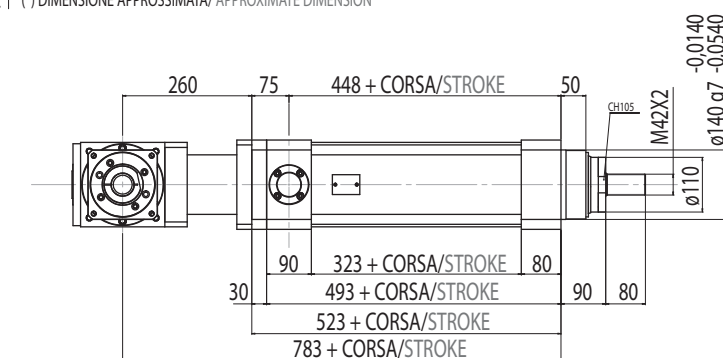
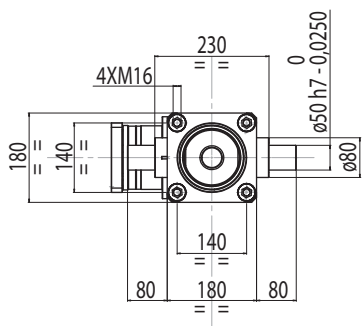
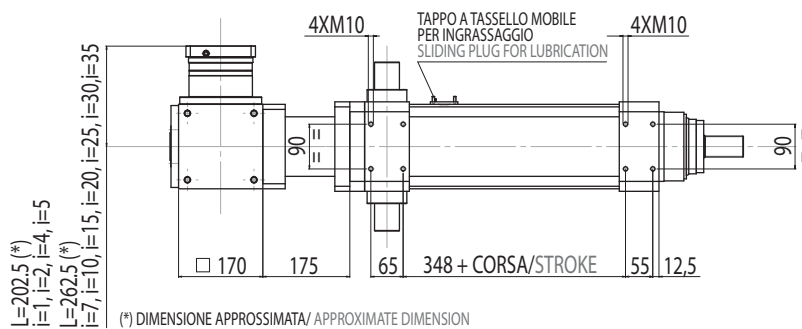

A210

(ATB210-FL1)

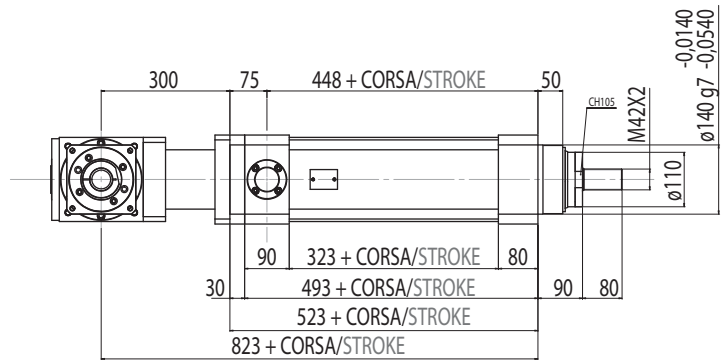
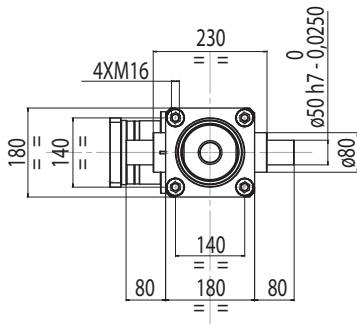
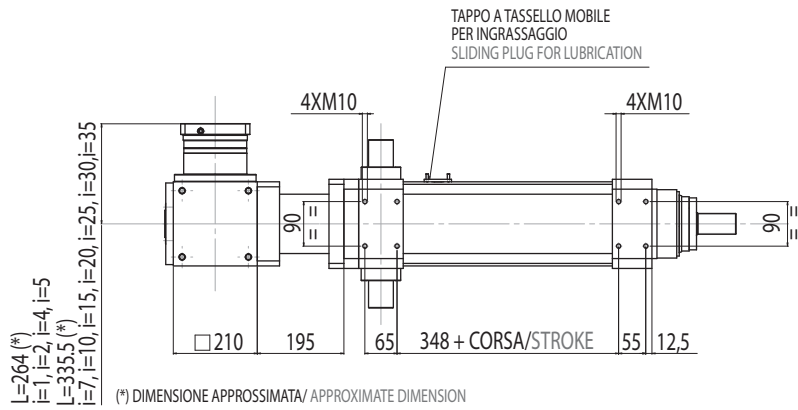

B+R
MODULO BASE + TRASMISSIONE A CINGHIA IN PARALLELO
PER MOTORE CUSTOM
BASIC MODULE + PARALLEL FOR CUSTOM MOTORS
BELT GEARBOX STAGE

R00

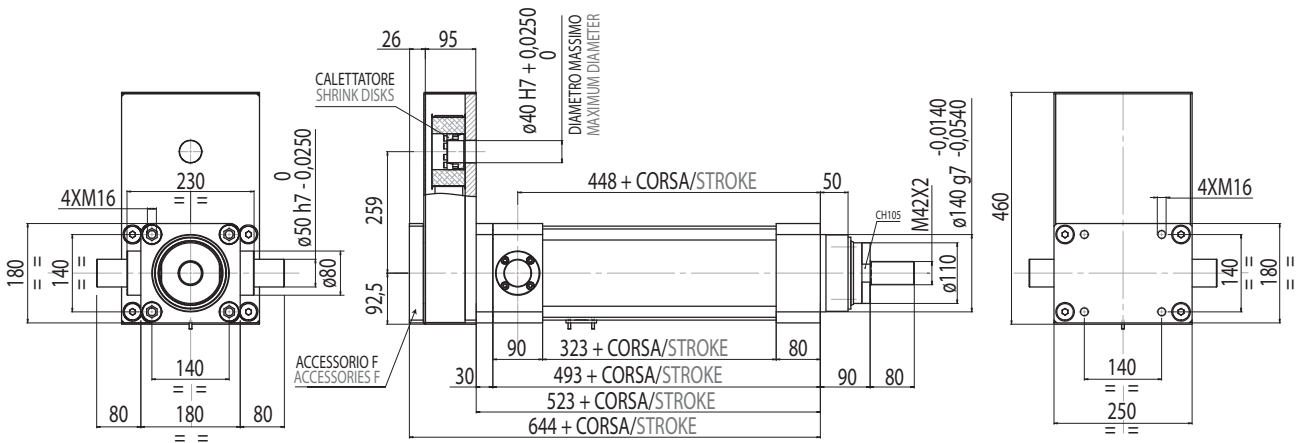
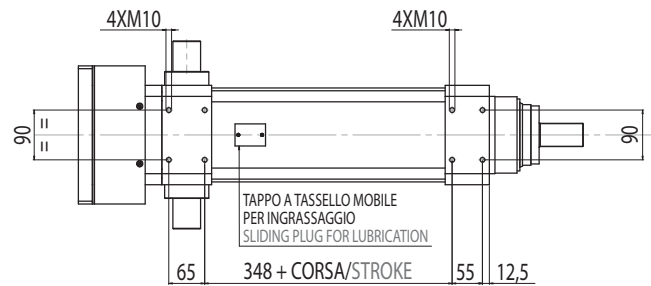
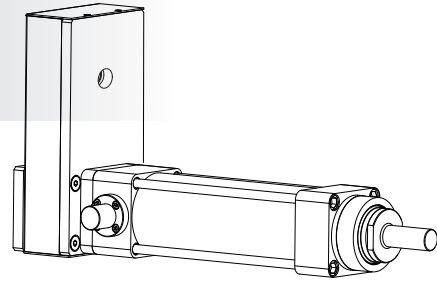

B+R

MODULO BASE + TRASMISSIONE A CINGHIA IN PARALLELO
+ RIDUTTORE EPICICLOIDALE R120/R155

BASIC MODULE + PARALLEL BELT GEARBOX STAGE
+ IN-LINE PLANETARY GEARBOX REDUCTION STAGE R120/R155

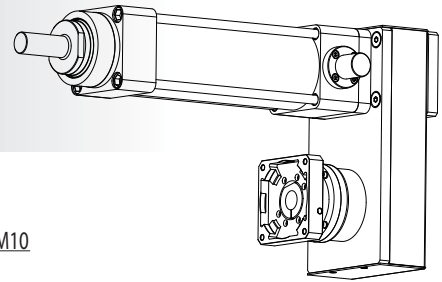

R120

(AE 120)

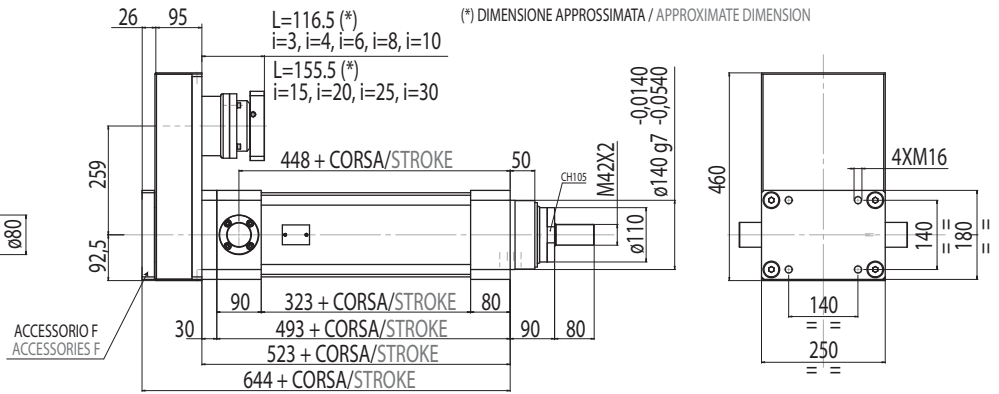
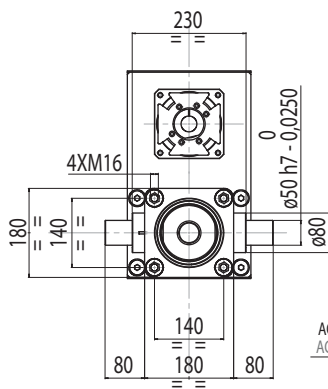
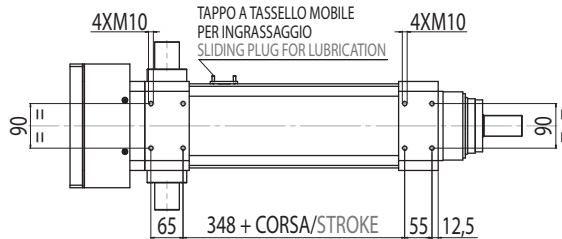

R155

(AE 155)

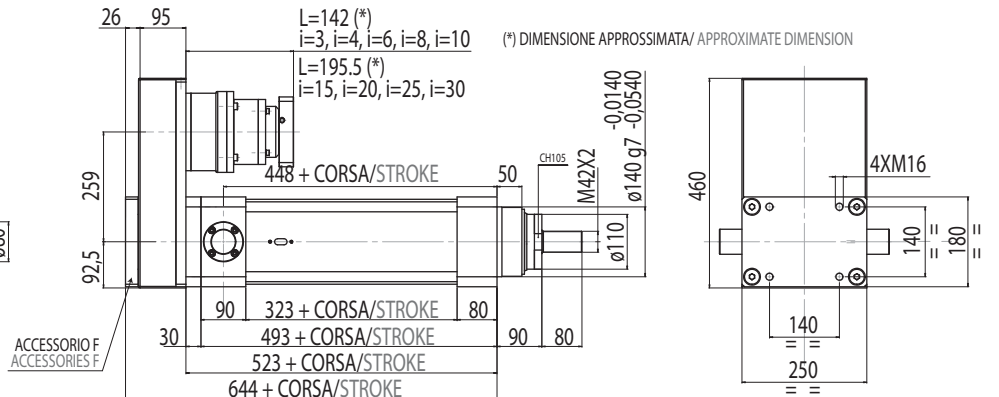
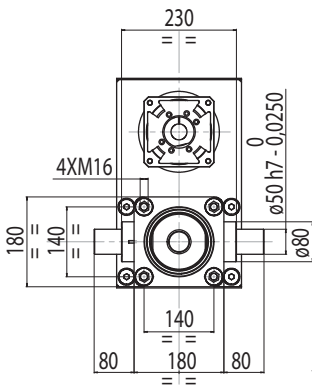
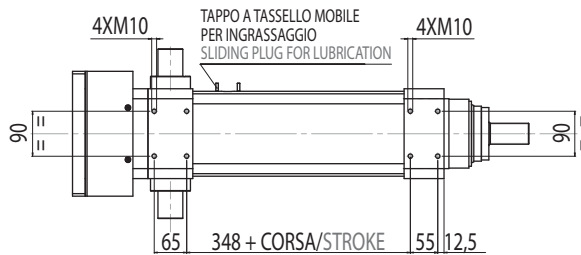

5.3

IE 240

5.3.1 Caratteristiche tecniche

5.3.1 Technical features

ISOMOVE IE 240			25
P	PASSO VITE SCREW LEAD	[mm]	25
D	DIAMETRO VITE SCREW DIAMETER	[mm]	80
F_d	CARICO MASSIMO DINAMICO APPLICABILE MAX ADMISSIBLE DYNAMIC LOAD	[N]	350000
C_{in,max}	PER AVERE TO GET $F_a = F_d$	[Nm]	1548
C_{m,max}	"CASO 1" / "CASE 1": B	[Nm]	1548
	"CASO 2" / "CASE 2": B+D (R155/R205/R235/RA155/RA205/RA235)	[Nm]	$\left[\frac{1720}{R} \right] + C_s$ R = rapporto di riduzione del riduttore / riduttore rinviato R = planetary / angle bevel gearbox reduction ratio
F_{st}	CARICO MASSIMO STATICO APPLICABILE MAX ADMISSIBLE STATIC LOAD	[N]	500000
V_{out,max}	VELOCITÀ DI TRASLAZIONE MASSIMA IN USCITA / ROTAZIONE MASSIMA VITE RDS	[mm/sec]	417/1000
N_{in,max}	MAX OUTPUT SPEED / MAX BALLSCREW ROTATING INPUT SPEED	[rpm]	
S_{max}	CORSA MASSIMA STANDARD MAX STANDARD STROKE	[mm]	1100**
G_{s,max}	GIOCO ASSIALE MASSIMO PER CHIOCCIOLA STANDARD MAX AXIAL BACKLASH FOR STANDARD BALLSCREW ASSEMBLY	mm	0,05
G_z	GIOCO "0" DELLA CHIOCCIOLA "0" BACKLASH BALLSCREW ASSEMBLY		A RICHIESTA / UPON REQUEST
L_{10,Km}	DURATA LIFETIME	Km	VEDI TABELLA / SEE TABLE pg. 175
	VERSIONI DISPONIBILI AVAILABLE TYPES		D-R155 / D-R205 / D-R235 D-RA155 / D-RA205 / D-RA235
F_{a,max}	POSSIBILE CON IL RIDUTTORE EPICICLOIDALE INDICATO POSSIBLE VALUE WITH THE INDICATED PLANETARY GEARBOX	[N]	AE155-AER155/60200*** AE205-AER205/103000*** AE235-AER235/350000***
	ACCESSORI DISPONIBILI AVAILABLE ACCESSORIES		NON DISPONIBILE / NOT AVAILABLE

*** È il valore massimo ottenibile con il rapporto di riduzione disponibile avente il minore valore di coppia erogabile.
It is the max obtainable value with the available on tables reduction ratio which has the lowest value of nominal output torque.

RIDUTTORI-RINVII "STANDARD SETEC GROUP DISPONIBILI"
"STANDARD SETEC GROUP AVAILABLE" PLANETARY-ANGLE BEVEL GEARBOXES

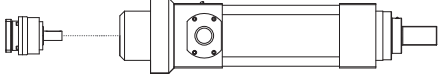
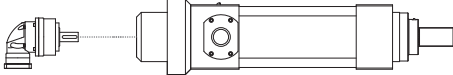
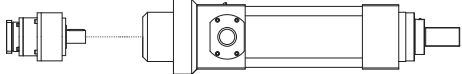
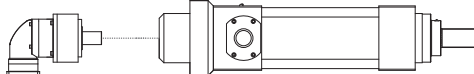
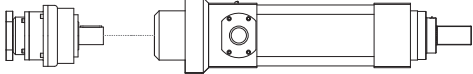
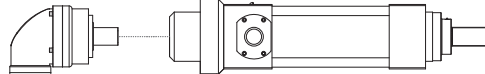
TRASMISSIONE CON RIDUTTORE PLANETARY GEARBOX STAGE	 AE155	MODULO BASE BASIC MODULE	 AER155	MODULO BASE BASIC MODULE
	 AE205	MODULO BASE BASIC MODULE	 AER205	MODULO BASE BASIC MODULE
	 AE235	MODULO BASE BASIC MODULE	 AER235	MODULO BASE BASIC MODULE

5.3.2 Calcolo durata

5.3.2 Lifetime calculation

IE 240 P = 25 mm	$L_{10,Km} = \left[\frac{800000}{F_{eq}} \right]^3 \cdot 25$	L_{10,Km} = [Km] F_{eq} = [N]
-----------------------------------	---	--

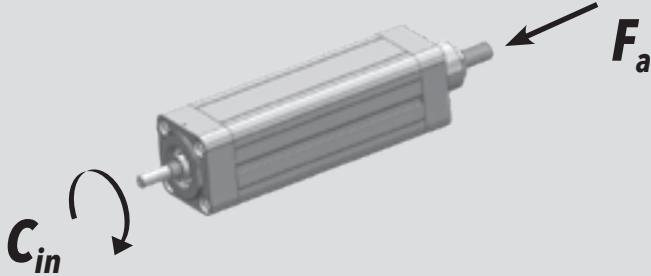

**5.2.3 Calcolo coppia in ingresso
al modulo base**

**5.2.3 Torque calculation at basic
module input shaft**

		
IE 240 P = 25 mm	$C_{in} = \left[\frac{F_a \cdot 25}{5652} \right]$	C_{in} = [Nm] F_a = [N]

5.3.4 Calcolo coppia motore

5.3.4 Motor torque calculation

<p>CASO / CASE</p> <p>1</p>	<p>ISOMOVE B</p>  $C_m = C_{in} \quad [Nm]$
<p>CASO / CASE</p> <p>2</p>	<p>ISOMOVE B+D (R155/R205/R235/RA155/RA205/RA235)</p>  $C_m = \left[\frac{C_{in}}{R \cdot \eta} \right] + C_s \quad [Nm]$ <p>R = rapporto di riduzione riduttore / rinvio planetary / angle bevel gearbox reduction ratio</p> <p>η = rendimento meccanico / mechanical efficiency = 0,90</p>

5.3.5 Caratteristiche dimensionali

5.3.5 Overall dimensions

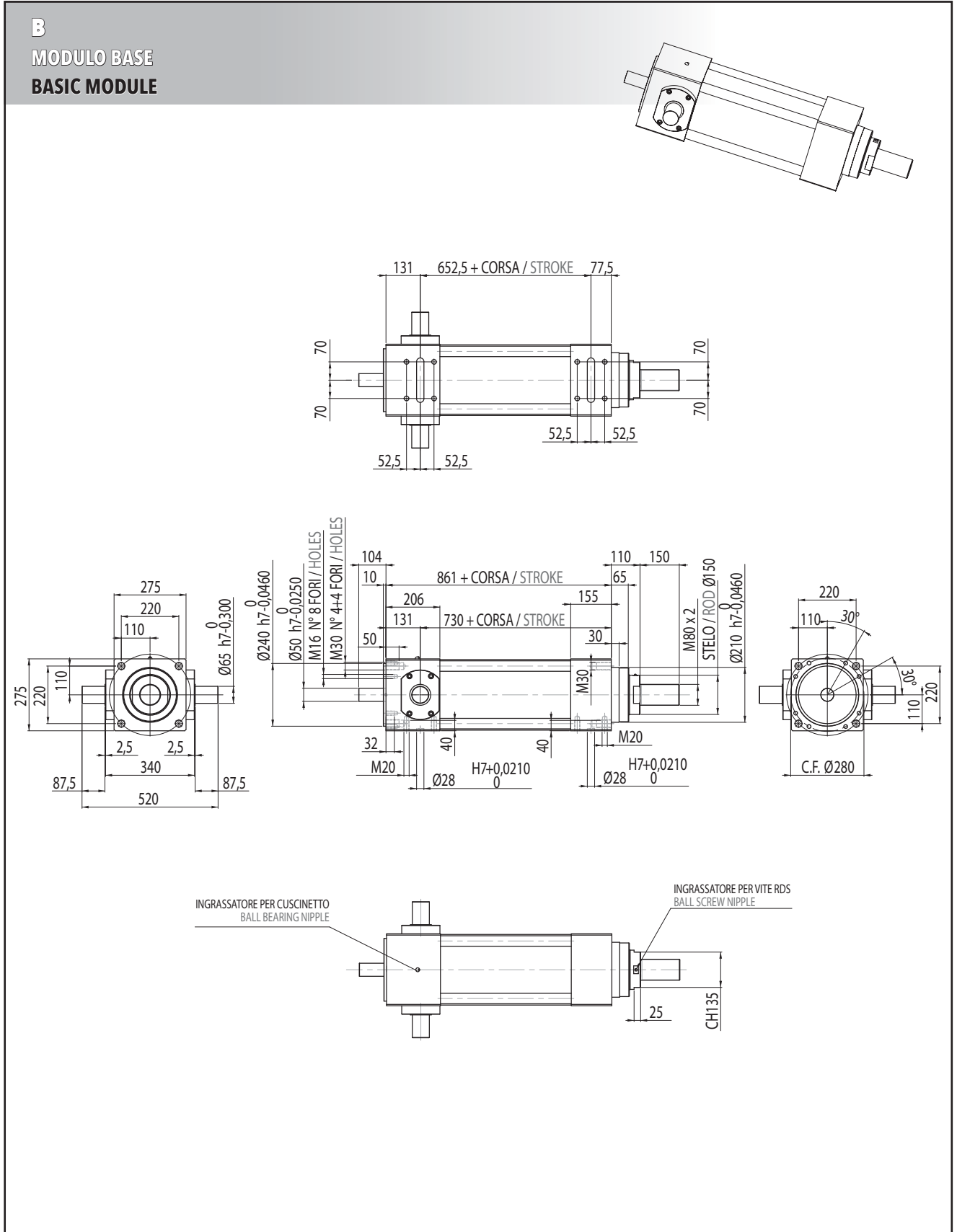

B+D

MODULO BASE + RIDUTTORE EPICICLOIDALE COASSIALE

BASIC MODULE + IN-LINE PLANETARY GEARBOX STAGE

R155

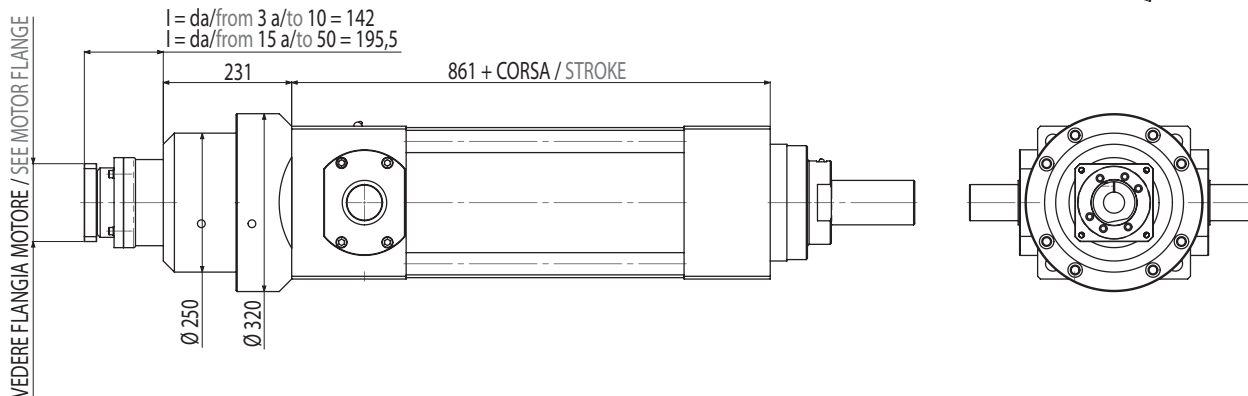
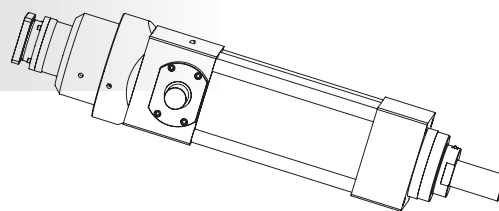

R205

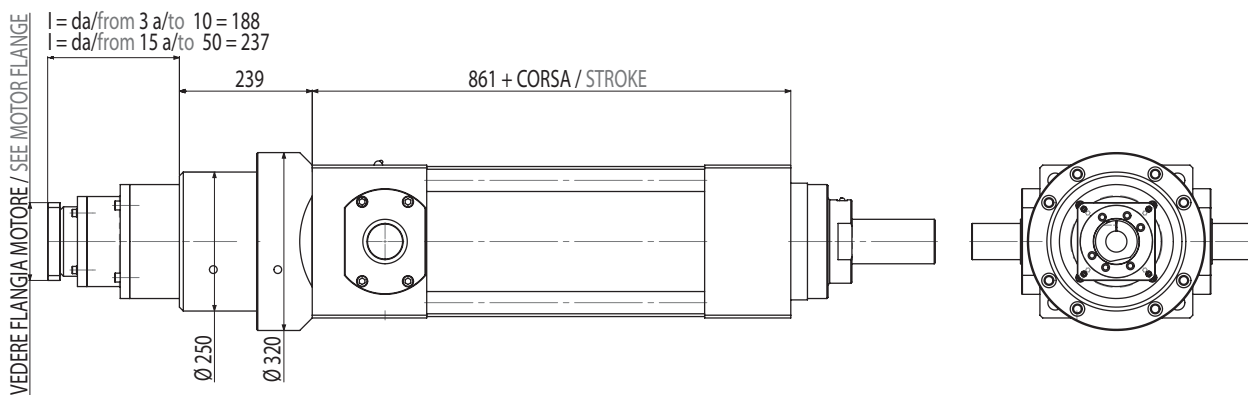

R235

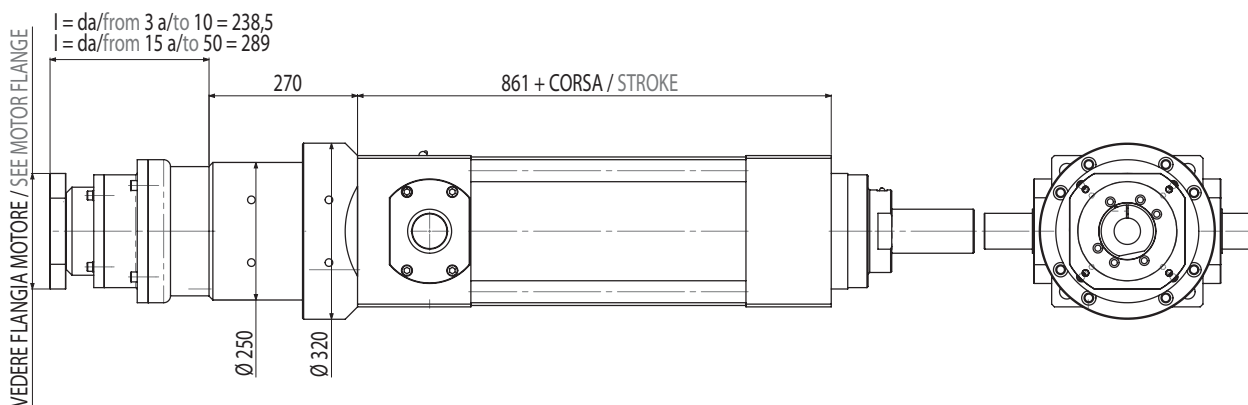

B+D

**MODULO BASE + RIDUTTORE EPICICLOIDALE ANGOLARE
BASIC MODULE + PLANETARY ANGLE BEVEL GEARBOX STAGE**

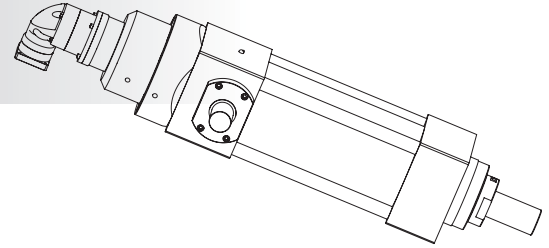

RA155

$l = da / \text{from } 3 \text{ a/to } 20 = 164,5$
 $l = da / \text{from } 25 \text{ a/to } 50 = 134$

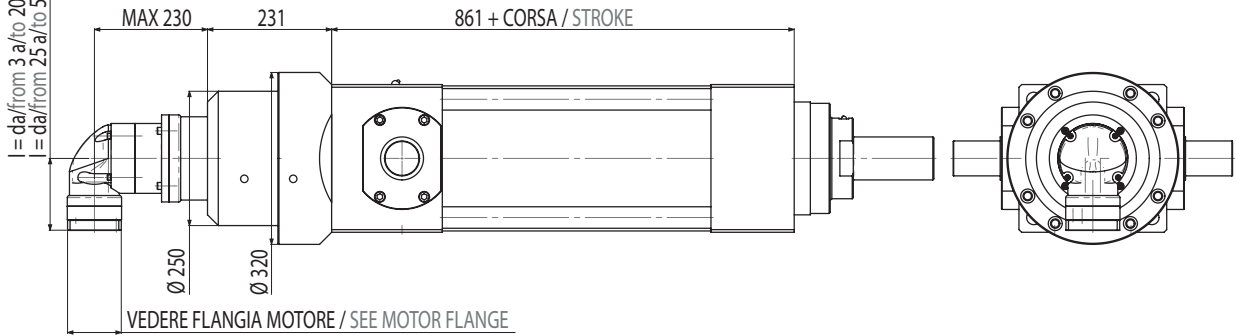

RA205

$l = da / \text{from } 3 \text{ a/to } 20 = 213,5$
 $l = da / \text{from } 25 \text{ a/to } 50 = 164,5$

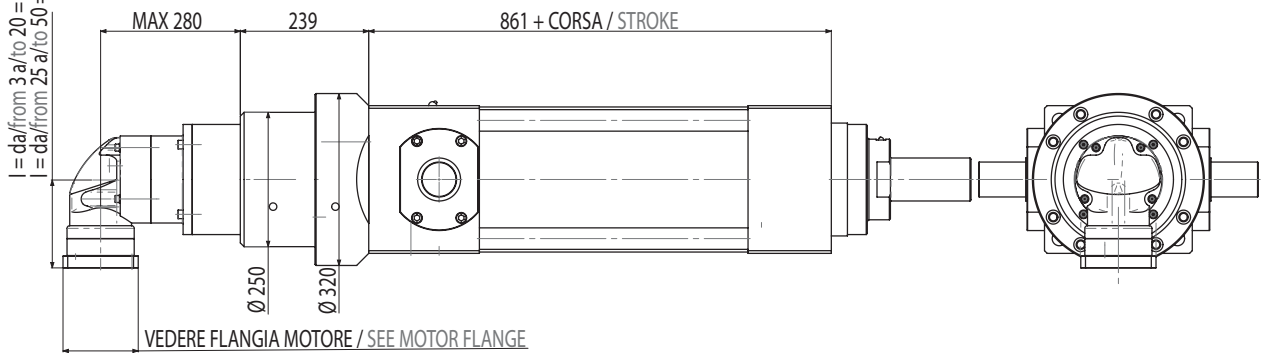

RA235

$l = da / \text{from } 3 \text{ a/to } 20 = 268,5$
 $l = da / \text{from } 25 \text{ a/to } 50 = 213,5$

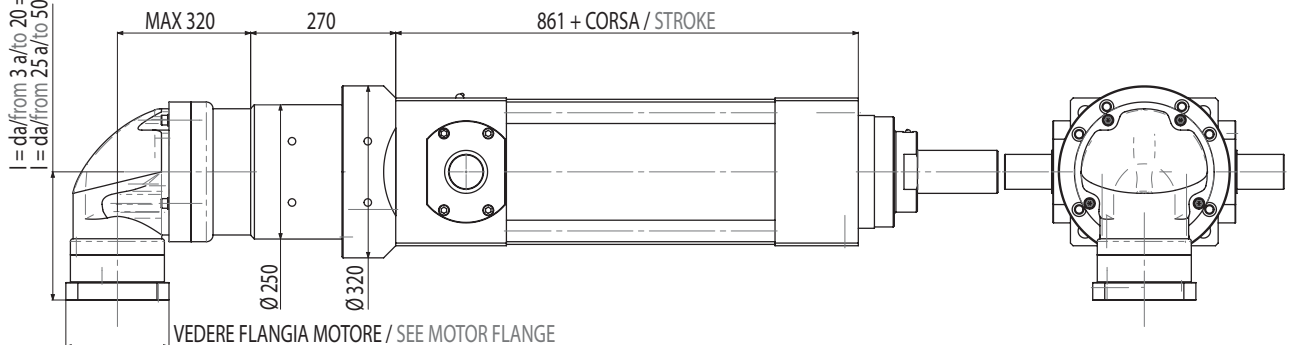

6.

Schede tecniche Riduttori / Rinvii angolari

Planetary gearboxes / Angle bevel gearboxes datasheets

Riduttori / Planetary gearboxes pg. 182

Rinvii angolari / Angle bevel gearboxes pg. 184

6.1

Scheda tecnica riduttori
Planetary gearboxes datasheets

RIDUTTORI SERIE "AE" / PLANETARY GEARBOXES "AE" SERIES									
MODELLO MODEL	R	AE050	AE070	AE090	AE120	AE155 AER155	AE205 AER205	AE235 AER235	
MONOSTADIO / 1 STAGE	3	14	39	91	146	239	412	798	
		0,33	0,44	0,77	1,98	2,53	4,84	8,8	
	4	13	35	98	203	379	735	1190	
		0,33	0,44	0,77	1,98	2,53	4,84	8,8	
	5	15	42	112	231	455	840	1400	
		0,33	0,44	0,77	1,98	2,53	4,84	8,8	
	C_{rid} COPPIA NOMINALE IN USCITA NOMINAL OUTPUT TORQUE [Nm]	6	14	39	105	217	420	770	1330
			0,33	0,44	0,77	1,98	2,53	4,84	8,8
	C_s COPPIA A VUOTO CHE ASSORBE IL RIDUTTORE IDLE TORQUE [Nm]	7	13	35	98	210	385	770	1260
			0,33	0,44	0,77	1,98	2,53	4,84	8,8
		8	12	32	84	182	350	700	1120
			0,33	0,44	0,77	1,98	2,53	4,84	8,8
		9	10	28	70	161	315	630	1050
			0,33	0,44	0,77	1,98	2,53	4,84	8,8
		10	10	28	70	161	315	630	1050
			0,33	0,44	0,77	1,98	2,53	4,84	8,8
	BISTADIO / 2 STAGES	15	14	39	91	146	239*		
			0,17	0,17	0,28	0,55	1,43		
20		13	35	98	203	379*	735*	1190*	
		0,17	0,17	0,28	0,55	1,43	2,42	5,5	
25		15	42	112	231	455	840	1400	
		0,17	0,17	0,28	0,55	1,43	2,42	5,5	
C_{rid} COPPIA NOMINALE IN USCITA NOMINAL OUTPUT TORQUE [Nm]		30	14	39	105	217	420	770	1330
			0,17	0,17	0,28	0,55	1,43	2,42	5,5
C_s COPPIA A VUOTO CHE ASSORBE IL RIDUTTORE IDLE TORQUE [Nm]		35	13	35	98	210	385	770	1260
			0,17	0,17	0,28	0,55	1,43	2,42	5,5
		40	11,9	31,5	84	182	350	700	1120
			0,17	0,17	0,28	0,55	1,43	2,42	5,5
	45	10	28	70	161	315	630	1050	
		0,17	0,17	0,28	0,55	1,43	2,42	5,5	
VELOCITÀ MASSIMA IN INGRESSO AL RIDUTTORE [rpm] MAX GEARBOX INPUT SPEED		5000	5000	4000	4000	3000	3000	2000	
η RENDIMENTO DEL RIDUTTORE GEARBOX MECHANICAL EFFICIENCY		0,9	0,9	0,9	0,9	0,9	0,9	0,9	

* Non disponibili nella versione AER. / Not available in AER version.

RIDUTTORI SERIE "PGII" / PLANETARY GEARBOXES "PGII" SERIES					
MODELLO MODEL	R	PGII060	PGII080	PGII 120	
<p>MONOSTADIO / 1 STAGE</p> <hr/> <p>C_{rid} COPPIA NOMINALE IN USCITA NOMINAL OUTPUTTORQUE [Nm]</p> <hr/> <p>C_s COPPIA A VUOTO CHE ASSORBE IL RIDUTTORE IDLE TORQUE [Nm]</p>	3	29	77	152	
		0,1	0,4	0,8	
	4	29	79	156	
		0,1	0,4	0,8	
	5	28	83	154	
		0,1	0,4	0,8	
	7	25	67	139	
		0,1	0,4	0,8	
	10	19	48	109	
		0,1	0,4	0,8	
	<p>BISTADIO / 2 STAGES</p> <hr/> <p>C_{rid} COPPIA NOMINALE IN USCITA NOMINAL OUTPUTTORQUE [Nm]</p> <hr/> <p>C_s COPPIA A VUOTO CHE ASSORBE IL RIDUTTORE IDLE TORQUE [Nm]</p>	15	28	76	149
			0,1	0,3	0,4
16		29	81	160	
		0,1	0,3	0,4	
20		29	81	161	
		0,1	0,3	0,4	
25		28	86	160	
		0,1	0,3	0,4	
30		28	76	148	
		0,1	0,3	0,4	
35		25	70	144	
		0,1	0,3	0,4	
40		30	82	162	
		0,1	0,3	0,4	
50		28	86	160	
		0,05	0,3	0,4	
VELOCITÀ MASSIMA IN INGRESSO AL RIDUTTORE [rpm] MAX GEARBOX INPUT SPEED			4000	3600	3600
η RENDIMENTO DEL RIDUTTORE GEARBOX MECHANICAL EFFICIENCY			0,9	0,9	0,9

6.2

Scheda tecnica rinvii angolari
Angle bevel gearboxes datasheets

RINVII ANGOLARI SERIE "ATB" / ANGLE BEVEL GEARBOXES "ATB" SERIES									
MODELLO MODEL	R	ATB065	ATB075	ATB090	ATB110	ATB140	ATB170	ATB210	
MONOSTADIO / 1 STAGE <hr/> C_{rid} COPPIA NOMINALE IN USCITA NOMINAL OUTPUT TORQUE [Nm] <hr/> C_s COPPIA A VUOTO CHE ASSORBE IL RIDUTTORE IDLE TORQUE [Nm]	1	18	32	55	105	252	410	910	
		1,6	2,2	3,1	4,6	8,6	12,1	21,6	
	1,5	18	32	55	105	252	410	910	
		1,6	2,2	3,1	4,6	7,5	11	18,9	
	2	17	29	48	105	231	381	854	
		1,3	1,5	2,7	3,7	5	7,8	16,2	
	3	13	23	38	84	189	315	714	
		1,3	1,5	1,8	3	4,4	5,9	14,3	
	4	9	20	34	70	157	263	602	
		1,1	1,1	1,2	2,8	4	5,9	14,3	
	5	8	18	28	60	137	224	518	
		1,1	1,1	1,2	2,6	4	5,4	13,8	
	BISTADIO / 2 STAGES <hr/> C_{rid} COPPIA NOMINALE IN USCITA NOMINAL OUTPUT TORQUE [Nm] <hr/> C_s COPPIA A VUOTO CHE ASSORBE IL RIDUTTORE IDLE TORQUE [Nm]	10	17	20	48	105	146	146	301
			0,8	0,9	1	2	2,4	3,9	9,7
15		13	23	38	84	189	218	452	
		0,8	0,9	1	2	2,4	3,9	9,7	
20		9	20	34	70	157	263	602	
		0,8	0,9	1	2	2,4	3,9	9,7	
25		8	18	28	60	137	224	518	
		0,8	0,9	1	2	2,4	3,9	9,7	
35		8	18	28	60	137	224	518	
		0,8	0,9	1	2	2,4	3,9	9,7	
50		8	18	28	60	137	224	518	
		0,8	0,9	1	2	2,4	3,9	9,7	
VELOCITÀ MASSIMA IN INGRESSO AL RIDUTTORE [rpm] MAX GEARBOX INPUT SPEED			7000	6000	5000	4000	3000	3000	3000
η RENDIMENTO DEL RIDUTTORE GEARBOX MECHANICAL EFFICIENCY			0,9	0,9	0,9	0,9	0,9	0,9	0,9

7.

Note tecniche generali

General technical information

7.1

Extracorsa (corsa di sicurezza)
Extra-stroke (safety stroke)

L'attuatore non è costruito per usare la sua battuta meccanica interna per arrestarsi, pertanto nella scelta consigliamo di tenere in conto una corsa extra che eviti la collisione interna.

A titolo indicativo si può aggiungere alla corsa massima di lavoro S_I un valore per ogni lato pari 2 volte il passo $S_s = 2P$:

$$S = S_I + 2S_s$$

NOTA: per una corsa nominale S la corsa reale è comunque superiore di qualche millimetro.

The actuator is not built to stand internal mechanical stop, thus during selection process we advice take into account to add some additional stroke to avoid internal collision.

Just as an indication you can add to the max working stroke S_I an additional safety for each side which is twice the ballscrew pitch $S_s = 2P$:

corsa dell'attuatore
actuator's stroke

REMARK: the actual manufacturing stroke is anyway some millimeters longer the nominal stroke S .

7.2

Montaggio con attuatore basculante
Installation with tilting actuator

Nel caso in cui l'attuatore sia montato in modo da basculare con il suo asse durante la sua corsa (ovvero in tutti quei casi in cui non mantiene una posizione fissa nello spazio), ad esempio perché si usano i perni oscillanti laterali **PE** in combinazione con la forcella anteriore **FS** oppure con la testa a snodo sferico **SS**, il suo peso proprio lo sollecita a flessione.

Prevedere pertanto di usare un massimo della corsa totale S pari al 75% della stessa.

In all cases where the actuator is tilting during its stroke (i.e. all the cases where the actuator doesn't keep a fixed position during motion), because for example **PE** pins together with **FS** fork or **SS** joint are used; its weight creates a bending force on the actuator itself. Use then only 75% of the actuator stroke S .

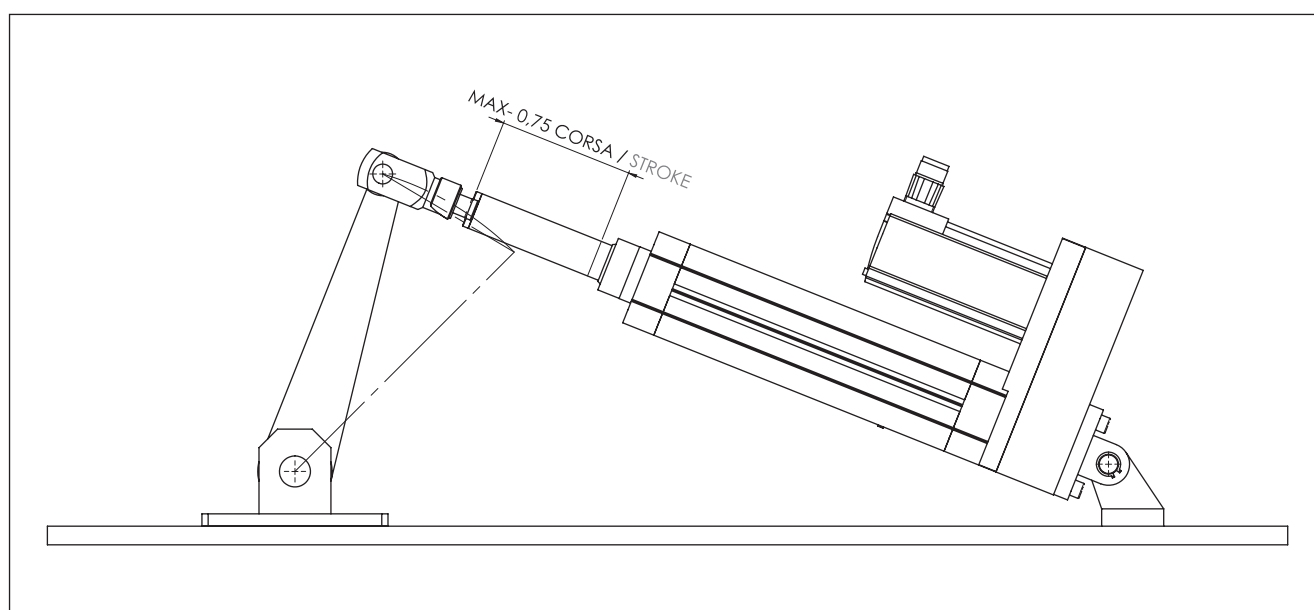

7.3

Grado protezione IP IP protection rate

Il MODULO BASE B00 ha un grado di protezione IP54.
Tutte le altre versioni: contattare il ns. ufficio tecnico.

BASIC MODULE B00 has an IP54 protection rate.
For all the other types: please contact our technical dept.

7.4

Lubrificazione Lubrication

La lubrificazione standard è a grasso.
L'attuatore è fornito lubrificato dal costruttore.
Per ogni altro dettaglio fare riferimento al MANUALE DI
INSTALLAZIONE-USO-MANUTENZIONE.

Standard lubrication is by grease.
The actuator is supplied already lubricated by the
manufacturer.
For any other detail please refer to INSTALLATION-
USE-MAINTENANCE HANDBOOK.

7.5

Posizione di montaggio Mounting position

L'attuatore, in linea generale, può essere montato
all'interno di un sistema in qualsiasi posizione.
Tuttavia, in fase di progettazione e scelta dell'attuatore,
vanno osservate tutte le condizioni di lavoro a cui verrà
sottoposto l'ISOMOVE.
Qualora l'attuatore venisse posizionato fisso in
orizzontale, tenere sempre in considerazione il peso
dello stesso al fine di selezionare il corretto sistema
di fissaggio: in questo caso si consiglia sempre di
supportare anteriormente e posteriormente l'attuatore.
Assicurarsi che il montaggio venga eseguito senza
deformazioni e sollecitazioni (assicurare ottime
planarità e ortogonalità delle superfici di appoggio).

In general terms the actuator can be mounted in any
position into the machine.
Anyway, during design and selection, please consider
all its the possible working condition.
If the actuator is mounted horizontally in a fixed
position, due to its proper weight it is always better to
use a front and a back support.
Please be sure during installation that its assembly into
the machine is not causing deformation and stresses to
the actuator itself (please respect very good tolerances
for planarity and orthogonality of the connection
machine parts).

7.6

Reversibilità Reversibility

In generale l'attuatore è reversibile, ovvero non
autobloccante.
Pertanto in applicazioni verticali prevedere un sistema
di frenatura esterno per ragioni di sicurezza.

In general terms the actuator is not self-locking; thus
consider to add an external braking system for safety
reason.

7.7

Capacità di fattore di servizio
Duty cycle rating

L'attuatore ha una capacità di fattore di servizio pari al 100%, ovvero per impiego continuo.

The actuator has duty cycle rating of 100%, i.e. for continuous duty.

7.8

Collegamento riduttore/rivio a modulo base
Torque transmission element between planetary /
angle bevel gearbox and basic module

IE 32 ÷ 100XL

Per tutti i modelli: si usano giunti a morsetto a gioco zero senza chiave / calettatori ad attrito.

For all models: zerobacklash servocouplings without keaway / friction shrink-disk are used.

IE 125 ÷ 160

B+R: calettatori ad attrito.

B+R: shrink-Disks.

B+D e B+A: giunto a morsetto a gioco zero con chiave.

B+D and B+A: zero backlash servocouplings with keaway.

ISOMOVE-E the evolution

Attuatori lineari meccanici di precisione per alta dinamica
Precision mechanical linear actuators for high dynamics



[®] **JETEC** 
COMPONENTS CONTROLS MOTION SYSTEMS



TORINO

Direzione Generale e Stabilimento di Produzione - Headquarter and Production Plant

Via Mappano, 17 - 10071 Borgaro T.se (TO) - T +39 011 451 8611 (centr. r.a.) - F +39 011 470 4891 - setec.to@setec-group.it

www.setec-group.com



MILANO

Via Meccanica, 5
20026 Novate (MI) - Z. I. Vialba
T +39 02 356 0990 - 382 01 590 (r.a.)
F +39 02 356 0943
setec.mi@setec-group.it



PADOVA

Via Secchi, 81
35136 Padova
T +39 049 872 5983
F +39 049 856 0965
setec.pd@setec-group.it



FIRENZE

Via Galileo Galilei, 3
50015 Bagno a Ripoli - Grassano (FI)
T +39 055 643 261
F +39 055 646 6614
setec.fi@setec-group.it

BOLOGNA

Via Del Lavoro, 6/A
40051 Altedo (BO)
T +39 051 871 949 (3 linee r.a.)
F +39 051 870 329
setec.bo@setec-group.it

NETWORK INTERNAZIONALE DISTRIBUTORI AUTORIZZATI / INTERNATIONAL AUTHORIZED DISTRIBUTORS

AUSTRIA

TAT Technom Antriebstechnik GmbH
Technologiering 13-17
4060, Leonding
Austria
Tel. +43 7229 64840.0
Fax +43 7229 61817
tat@tat.at
www.tat.at

FINLAND

WEXON OY
Turvekuja 6,
00700, Helsinki,
Finland
Tel. +358 9 290 440
Fax +358 9 290 44100
wexon@wexon.com
www.wexon.fi

KOREA

SONG WON TRADING Co. Ltd.
Songwon Bldg 6
Seolleung-ro 121-gil Gangnam-gu
Republic of Korea
Tel. +82 2 5164111
Fax +82 2 5458322
tech@swt.co.kr
www.swt.co.kr

SPAIN

INTRA Automation, S.L.
Ronda Auguste y Louis Lumière, 45 -
Nave 3 - 46980, Parque Tecnológico
de Paterna - Valencia, España
Tel. +34 96 396 10 08
Fax +34 96 396 10 18
info@intraautomationsl.com
www.intraautomationsl.com

CANADA

DRIVE SYSTEMS GROUP Inc.
7150 Torbram Rd. Units 1 & 2
Mississauga, Ontario
Canada, L4T 3Z8
Tel. +1 905 405-0310
Fax +1 905 405-0313
georger@drivesystemsgroup.com
www.drivesystemsgroup.com

FRANCE

SNF
2, rue Marcel DASSAULT - BP 29
94510, La Queue en Brie
France
Tel. +33 1 4593 0525
Fax +33 1 4594 7995
contact@snt.tm.fr
www.snt.tm.fr

RUSSIA

OOO WEXON
Blagodatnaya ul., 67A, office 3
196105, St. Petersburg
Russia
Tel. +7 812 6432375
Fax +7 812 3266504
wexon@wexon.ru
www.wexon.ru

THE NETHERLANDS

DTS Aandrijftechniek BV
Parlevinkerweg 44 (Industrienummer 5068)
5928, NV Venlo
Nederland
Tel. +31 77 3961420
Fax +31 77 3961429
info@dts-aandrijftechniek.nl
www.dts-aandrijftechniek.nl

CHINA

**EURO POWER TRANSMISSION
& CONTROL Ltd.**
No.293, Xiuyan Rd, Pudong
201315, Shanghai, China
Tel. +86 21 510 284 51
Fax +86 21 510 288 72
ptc@europtc.com
www.europtc.com

GERMANY

A-Drive Technology GmbH
Ziegelhüttenweg 4
65232, Taunusstein,
Deutschland
Tel. +49 0 6128 9755-0
Fax +49 0 6128 9755-55
info@a-drive.de
www.a-drive.de

SLOVAK REPUBLIC

OPIS Engineering s.r.o.
Lúčna 476
03202, Závažná Poruba,
Slovenská Republika
Tel. +421 445 547 234
Fax +421 903 390 520
info@opis.sk
www.opis.sk

TURKEY

AKTEC Mühendislik ve Ticaret Ltd.
Veko Giz Plaza
Maslak Meydan Sokak No. 3, Kat. 13/14
34398, Maslak, Istanbul, Turkey
Tel. +90 212 705 36 32
Fax +90 212 705 36 36
info@aktec.tc
www.aktec.tc

CZECK REPUBLIC

OPIS Engineering k.s.
Selská 64
61400, Brno,
Česká Republika
Tel. +420 543 330 055
Fax +420 543 242 653
info@opis.cz
www.opis.cz

GERMANY

GEMOTEG GmbH + Co.KG
Walkenmühleweg 49
72379, Hechingen,
Deutschland
Tel. +49 7471 9301030
Fax +49 7471 9301059
info@gemoteg.de
www.gemoteg.de

SLOVENIA

M&M Intercom d.o.o.
Letališka cesta 33a
1000, Ljubljana,
Slovenija
Tel. +386 1 52 00 116
Fax +386 1 52 49 072
info@mm-intercom.si
www.mm-intercom.si

UNITED KINGDOM

GAPP AUTOMATION Ltd.
6 Kempston Court, Manor Road,
Kempston Hardwick, Bedford,
MK43 9PO, United Kingdom
Tel. +44 0 1234 924324
Fax +44 0 1234 924325
ggoodge@gapp.co.uk
www.gapp.co.uk