

ILA1 with AC synchronous servo motor

Presentation

The Lexium integrated drives comprise motor, control electronics and a fieldbus interface:

- CANopen DS301 (IL●1F)
- PROFIBUS DP (IL●1B)
- RS 485 (IL●1R)

The IL●1 product group includes:

- ILA1 with AC synchronous servo motor
- ILE1 with brushless DC motor
- ILS1 with 3-phase stepper motor

ILA1 – the Integrated Drive System for dynamic processes

ILA1 has an AC synchronous servo motor. This motor is characterised by high dynamics with the possibility of short-term overcurrent during acceleration.

ILE1 – the Integrated Drive System for automatic format adjustment

ILE1 is fitted with a brushless DC motor.

The brushless DC motors have high detent torque at zero current. This makes a holding brake unnecessary in most applications.

In combination with the electronics, ILE1 has the characteristics of an absolute encoder.

ILS1 – the Lexium integrated drives for short-distance positioning

With its 3-phase stepper motor, ILS1 offers high torque at low speeds of rotation.

ILS1 are ideally suited as drives in velocity mode with excellent constant velocity characteristics and also for high-resolution positioning. Commissioning the stepper motor drives is simple because it is not necessary to adjust the control loop.

Special features

ILA1 with AC synchronous servo motor

- High dynamics and high peak torque
- High-resolution singleturn encoder with a resolution of 16384 increments/revolution (0.02°)
- Optionally with multiturn encoder with a resolution of 16384 increments/revolution (0.02°) with a positioning range of 4096 revolutions
- Optionally with integrated holding brake
- Planetary gear available as options

ILE1 with brushless DC motor

- High detent torque
- Quasi-absolute encoder, therefore, no homing required after switching off and on
- Optionally available with spur wheel gear or worm gear; planetary gear available as options

ILS1 with 3-phase stepper motor

- High continuous stall torque
- Good constant velocity characteristics
- High positioning resolution (0.018°)
- Optionally with holding brake (ILS1●85 only)
- Planetary gear available as options

Electronics

The electronic system comprises control electronics and power amplifier. They have a common power supply. The Lexium integrated drives can be parameterised and controlled via the fieldbus interface.

Four different 24 V signals are also available. They can be used as input or output.

Supply voltage

IL●1 can be operated with a voltage range of 24 V to 36 V.

Connection technologies

IL●1 have the following connections:

- Supply voltage 24 ... 36 V $\overline{=}$
- Fieldbus interface: CANopen DS301, PROFIBUS DP or RS 485
- 24 V signal interface for four inputs/outputs
- Signal interface for "Safe Torque Off" safety function ("Power Removal")

Fieldbus interface

The following fieldbuses can be connected to the fieldbus interface depending on the device version:

- CANopen (DS301 protocol)
- PROFIBUS DP-V0 (data format as per Profidrive V2.0 PPO Type 2)
- RS 485 (manufacturer-specific protocol)

The fieldbus interface is used to parameterise and control the Integrated Drive System.

In addition, the Integrated Drive System can be commissioned with a PC connected to the fieldbus interface and the PC commissioning software. This requires a compatible fieldbus converter, such as USB-CANopen, USB-RS 485, RS 232-RS 485 or USB-Profibus (see accessories).

24 V signal interface

Four 24 V signals are available, which can be used either as an input or an output.

The 24 V signals are available to the master controller via the fieldbus. They can also be used for predefined functions, such as for connection of limit switches and reference switches.

The 24 V power supply to the outputs is internal via the supply voltage of the Integrated Drive System.

Signal interface for "Safe Torque Off" safety function ("Power Removal")

The integrated "Safe Torque Off" safety function ("Power Removal") enables a stop of category 0 or 1 as per IEC/EN 60204-1 without external power contactors. The supply voltage does not have to be interrupted. This reduces the system costs and response times.

The "Safe Torque Off" safety function ("Power Removal") is activated via two redundant 24 V input signals (low active).

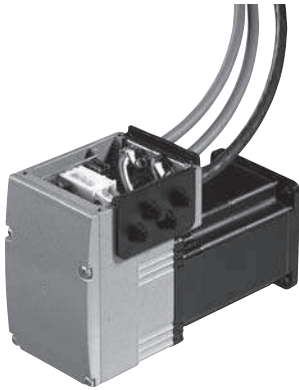

Integrated drive system with printed circuit board connectors

4

Connection technologies (continued)

Printed circuit board connector

Printed circuit board plug connectors are preferably used for cabling series machines with cable harnesses.

- Fieldbus and I/O signal connection with connector “Molex Micro Fit”
 - Power supply connection with “AMP Positive Lock” crimp contacts
- Two cable entries are required for cabling the Lexium integrated drives (see accessories, page 4/107).

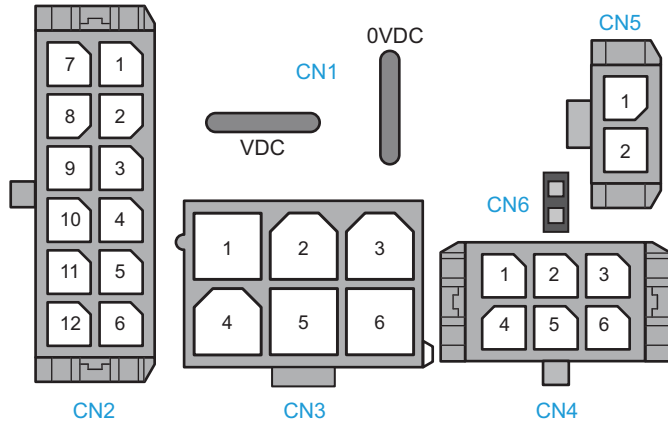

Printed circuit board connector, overview of connections

| Connection | Assignment |
|------------|---|
| CN1 | Supply voltage $\bar{\text{V}}$ |
| CN2 | For all IL●1: fieldbus interface for PROFIBUS DP For ILA1●57 only: interface for PROFIBUS DP and “Electronic Gear” operating mode (reference signal) |
| CN3 | Fieldbus interface for CANopen DS301 or RS 485 |
| CN4 | 24 V signal interface |
| CN5 | Interface for “Safe Torque Off” safety function (“Power Removal”) |
| CN6 | Jumper for disabling “Safe Torque Off” safety function (“Power Removal”) |

Industrial connectors (optional)

Lexium integrated drives with industrial connectors are preferably used in special machines and small series.

The device version with industrial connectors has a connector housing cover with two M12 circular connectors for the fieldbus connection and a Hirschmann STASEI 200 connector for connection of the power supply.

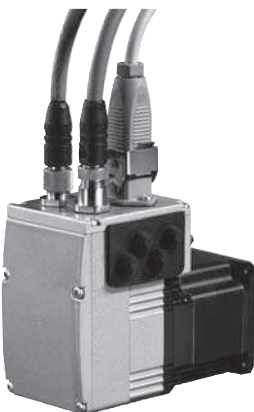

Integrated drive system with industrial connectors

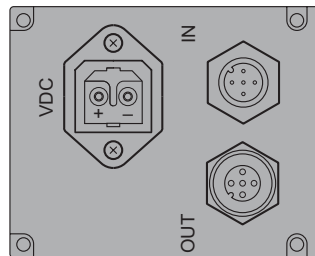

Industrial connector, overview of connections

Connection technologies (continued)

I/O signal inserts

One or two I/O signal inserts with industrial connectors can be ordered for connection of the I/O signals (see accessories, pages 4/109 and 4/110).

The 24 V power supply to the outputs is internal. Different I/O signal inserts are available for this purpose.

I/O signal insert without "Safe Torque Off" safety function ("Power Removal")

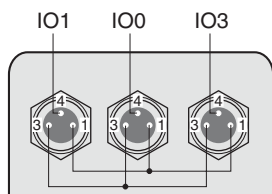

Inserts for three I/O signals

I/O signal inserts with "Safe Torque Off" safety function ("Power Removal")

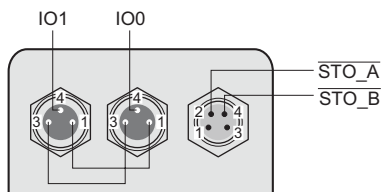

Insert for two I/O signals and STO signals for safety function

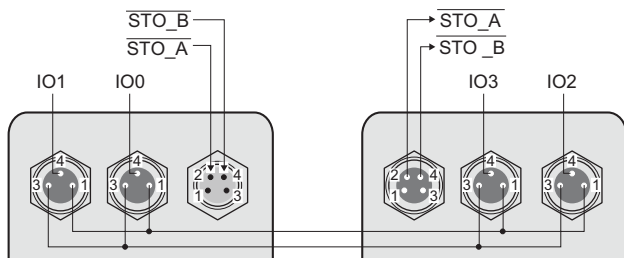

Inserts for four I/O signals and STO signals for safety function

Connection example I/O signal

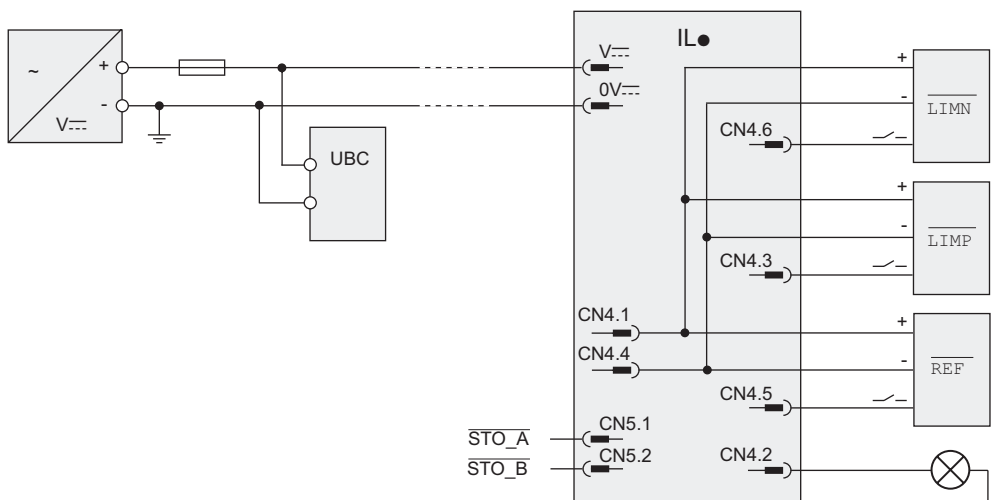

Connection example with four I/O signals

Configuration via parameter switches

The following settings can be made at the Integrated Drive System via parameter switches:

- PROFIBUS DP
 - Setting fieldbus address
 - Activating terminating resistor
- CANopen DS301 and RS 485
 - Setting fieldbus address
 - Setting baud rate
 - Activating terminating resistor
 - Setting pulse input for "electronic gear" operating mode (pulse/direction or A/B signals), only with ILA1●57 with singleturn encoder

Operating modes

Overview

The following operating modes can be set via the fieldbus:

- Electronic gear (only ILA1●57 with singleturn encoder)
 - Profile velocity
 - Jog
 - Profile position
 - Homing

Electronic gear (only ILA1●57 with singleturn encoder)

In "Electronic Gear" operating mode with singleturn encoder, the reference signals are supplied from an encoder (A/B signals) or a controller (pulse/direction signals) and a new position reference value is calculated using an adjustable gear ratio.

Reference value setting

The reference values are supplied as pulse/direction or A/B encoder signals (adjustable via parameter switch). In the case of ILA1●57 with PROFIBUS DP, only pulse/direction signals can be used as reference values.

Application example

Synchronisation of motion sequences, e.g. cutting material on a conveyor belt.

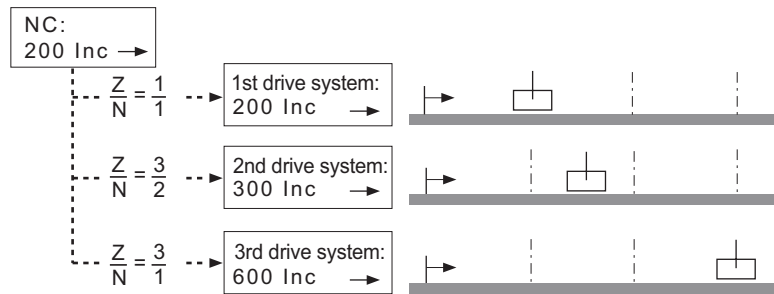

"Electronic Gear" operating mode

Profile velocity

In operating mode "Profile velocity", a reference speed for the motor is set and a movement without a target position is started. This speed is maintained until a different reference speed is specified or the operating mode is changed.

Reference value setting

The reference value is set via fieldbus or PC.

Application example

Application of paint in CD manufacture

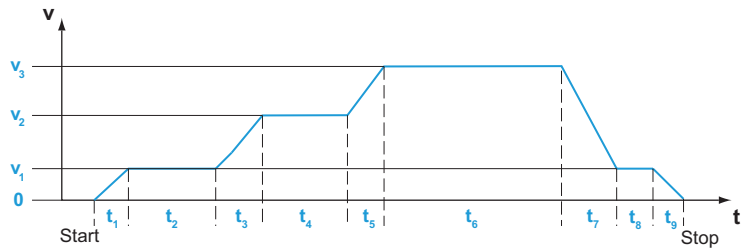

Profile velocity

- t_1, t_3, t_5 = acceleration
- t_2, t_4, t_6, t_8 = constant movement
- t_7, t_9 = braking

Jog mode

The motor moves by one distance unit or at constant speed in continuous operation. The value of the distance unit, the speed levels and the change-over time in continuous operation can be adjusted manually.

Reference value setting

The reference value is set via fieldbus or PC.

Application example

Setting up a machine during commissioning

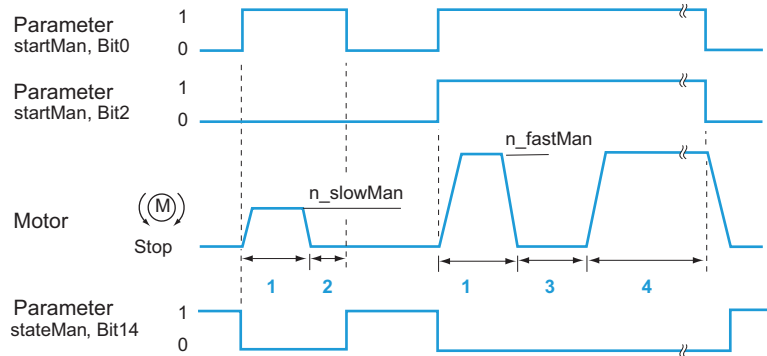

Jog, slow and fast

- 1 step_Man
- 2 $t < \text{time_Man}$
- 3 time_Man
- 4 Continuous operation

Profile position

In the operating mode "Profile Position", the motor is positioned from a point A to a point B with a positioning command.

Settings

The positioning path can be specified in two ways:

- Absolute positioning, reference point is the zero point of the axis
- Relative positioning, reference point is the current position of the motor

Reference value setting

The reference value is set via fieldbus or PC.

Application example

Pick-and-place with a linear robot

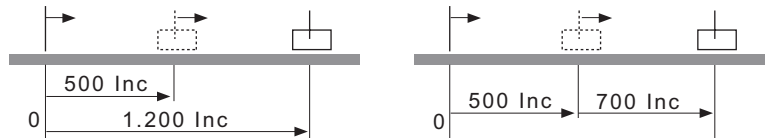

Operating mode "Profile Position", absolute and relative

Homing

There are two types of the "Homing" operating mode:

- Reference movement
 - Specifying the dimension reference by approach to a limit or reference switch
- Position setting
 - Specifying the position reference relative to the current motor position

Note: In the case of ILA1 with multiturn encoder, a valid actual motor position is available immediately after starting. Therefore, homing to external limit switches is not required.

Reference movement

During reference movement, the motor moves to a defined position on the axis. The position is defined by a mechanical switch:

- LIMP, LIMN limit switches
- REF reference switch

Types of reference movements

There are six standard reference movements:

- Movement to negative limit switch LIMN
- Movement to positive limit switch LIMP
- Movement to REF reference switch with first movement counterclockwise
- Movement to REF reference switch with first movement clockwise
- Reference movement to index pulse with clockwise or counterclockwise rotation (not with ILE1)
- Reference movement to block = mechanical stop (ILE1 only)

Example 1: reference movement to limit switch

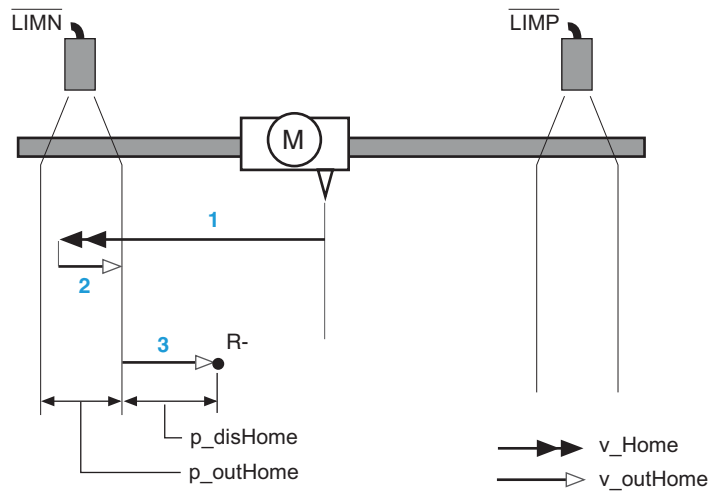

Operating mode "Homing", reference movement to limit switch

- 1 Movement to limit switch at search speed
- 2 Movement to switching edge at clearance speed
- 3 Movement to distance from switching edge at clearance speed

Example 2: position setting

Position setting can be used to execute a continuous motor movement without overtravelling the positioning limits.

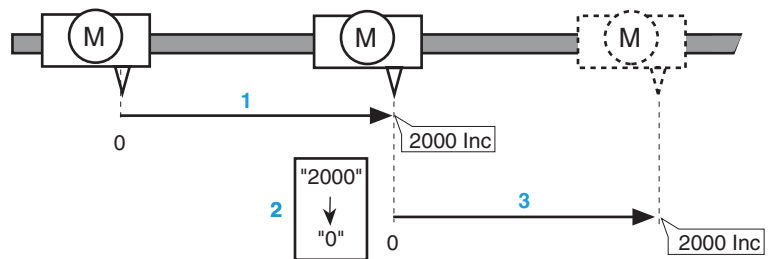

Positioning by 4000 increments with position setting

- 1 The motor is positioned 2000 increments.
- 2 The current motor position is set to position value 0 by position setting to 0 and the new zero point is defined at the same time.
- 3 The new target position is 2000 increments after triggering a new travel command by 2000 increments.

This procedure prevents overtravel of the absolute position limits during positioning, because the zero point is continuously made to follow.

Reference value setting

The reference value is set via fieldbus or PC.

Application example

Setting a reference before switching to "Profile Position" mode

Additional operating modes

Additional operating modes can be activated via fieldbus or PC:

- Reversing direction of rotation of motor
- Programming inputs/outputs.
- Setting motion profile via profile generator
- Triggering "Quick Stop" function
- Fast position capture via signal input (Capture)

"Safe Torque Off" ("Power Removal") safety function

The Lexium integrated drive integrates the "Safe Torque Off" ("Power Removal") safety function which prevents unintended restarting of the motor. The motor no longer produces any torque if the safety function is active.

This safety function:

- Complies with the machine safety standard ISO 13849-1, performance level "d" (PL d).
- Complies with the standard for functional safety IEC/EN 61508, SIL2 capability (safety control-signalling applied to processes and systems). The SIL (Safety Integrity Level) capability depends on the connection diagram for the servo drive and for the safety function. Failure to observe the setup recommendations could inhibit the SIL capability of the "Safe Torque Off" ("Power Removal") safety function.
- Complies with product standard IEC/EN 61800-5-2 "Adjustable speed electrical power drive systems – Part 5-2: Safety requirements – Functional" for both stop functions:
 - Safe Torque Off ("STO") corresponds to Category 0 stop according to IEC/EN 60204-1. Standstill by immediate power shutdown to the machine drive elements (i.e. an uncontrolled stop).
 - Safe Stop 1 ("SS1") corresponds to Category 1 stop according to IEC/EN 60204-1. A controlled stop in which the machine drive elements are retained to effect the standstill. The final shutdown is ensured by an external Emergency stop module with safe time delay, e.g. Preventa XPS-AV (1).

The "Safe Torque Off" ("Power Removal") safety function has a redundant electronic architecture (2) which is monitored continuously by a diagnostics function.

This PL d and SIL2 safety function is certified as conforming to these standards by the TÜV certification body in the context of a voluntary certification.

(1) Please refer to the "Safety functions and solutions using Preventa" catalogue.

(2) Redundant: Consists of mitigating the effects of the failure of one component by means of the correct operation of another, assuming that faults do not occur simultaneously on both.

Examples of applications of the safety function

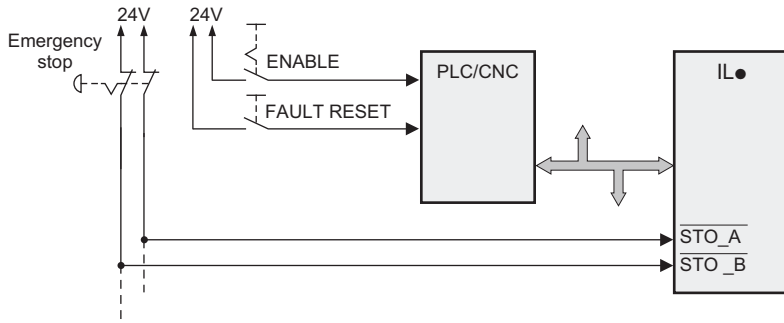

Example of Category 0 Stop

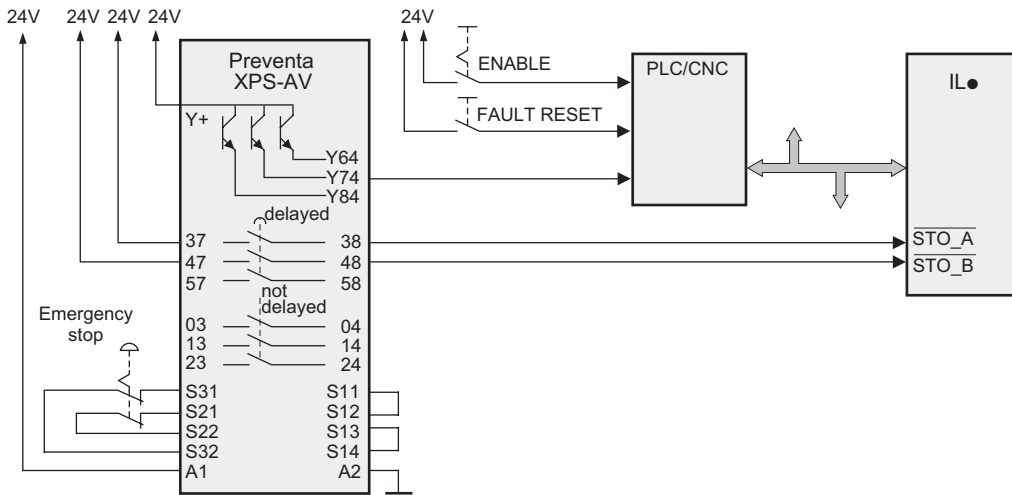

Example of Category 1 Stop