

Lexium integrated drives

IL●2 for DeviceNet, EtherCAT, Modbus TCP, Ethernet Powerlink

ILE2 with brushless DC motor

Description

ILE2 comprise control electronics with a fieldbus interface for DeviceNet, EtherCAT, Modbus TCP or Ethernet Powerlink and a brushless DC motor. ILE2 is optionally available with straight teeth gear or worm drive and printed circuit board connectors or industrial connectors.

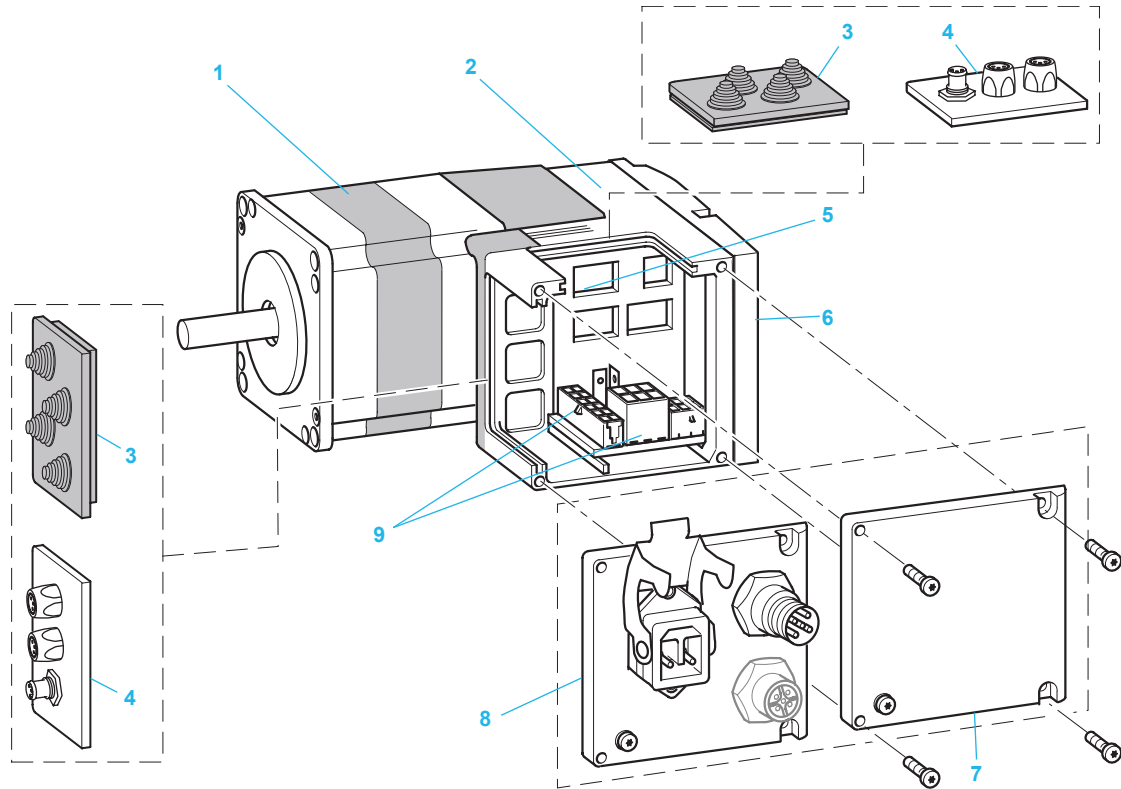

- 1 Brushless DC motor
- 2 Electronics housing
- 3 Insert cable entry (accessory)
- 4 I/O insert with industrial connectors (accessory)
- 5 Settings via parameter switches
- 6 Cover for electronics housing
- 7 Cover for Lexium integrated drives with option "PCB connector"
- 8 Cover for supply voltage --- V and fieldbus connection for Lexium integrated drives with option "industrial connector"
- 9 Electrical interfaces

Certifications		
Conformity to standards		Lexium integrated drives have been developed to comply with the stringent international standards and with the recommendations for adjustable speed power drive systems, specifically: IEC/EN 61800-3 (noise immunity to conducted and radiated high-frequency signals) and IEC/EN 50178 (resistance of devices to vibration).
	EMC immunity	EN 61800-3:2001, second environment
	Conducted and radiated EMC emissions	EN 61800-3:2001-02; IEC 61800-3, Ed.2 <ul style="list-style-type: none"> ■ Power supplies without external mains filter: <ul style="list-style-type: none"> □ C3 up to 10 m supply cable length ■ Power supplies with external mains filter: <ul style="list-style-type: none"> □ C2 up to 20 m supply cable length □ C3 up to 50 m supply cable length
CE marking		The Lexium integrated drives are CE marked in accordance with the European Machinery Directive (98/37/EEC) and the European EMC Directive (2004/108/EEC).
Product certifications		UL (USA), cUL (Canada)
		TÜV certification: Lexium integrated drives are TÜV-certified for device safety and medical devices. The certification includes: <ul style="list-style-type: none"> ■ Functional safety of electrical/electronic/programmable safety-related electronic systems (IEC 61508:2000; SIL 2) ■ Safety of machinery – functional safety of safety-related electrical and electronic and programmable electronic control systems (IEC 62061:2005; SILcl2) ■ Safety of machinery – safety-related parts of control systems – Part 1: General principles for design (ISO 13849-1:2006; PL d (Category 3))

Ambient conditions		
Ambient temperature (1)	°C	0 ... 55; power reduction by 2%/°C at 40 ... 55
Max. permissible temperature of the power amplifier	°C	105
Max. permissible temperature of the motor (2)	°C	110
Transport and storage temperature	°C	-25 ... +70
Installation height without power reduction	m	< 1000 m above mean sea level
Relative humidity	%	15 ... 85 (not condensing)
Vibration load during operation as per DIN EN 60068-2-6	Number of cycles	10
	Acceleration amplitude:	m/s ² 20
	Frequency range	Hz 10 ... 500
Continuous shocks as per DIN EN 60068-2-29	Number of shocks	1000
	Peak acceleration	m/s ² 150
Shaft wobble and perpendicularity		According to EN 50347 (IEC 60072-1)
Degree of protection as per DIN EN 60034-5		Total except shaft bushing IP54, shaft bushing IP41

Electrical data		
Supply voltage (CN1)		Corresponds to PELV according to DIN 19240, protected against reverse polarity
Supply voltage range (absolute limit values)	--- V	18 ... 55.2
Nominal supply voltage	--- V	24 / 48
Ripple at nominal voltage	V _{pp}	≤ 3.6
Max. continuous current consumption	A	5,5
Peak current consumption	A	7
Inrush current		Charging current for capacitor C=1500 µF
External fuse	A	16
Fieldbus interface (CN2)		
DeviceNet	Signal inputs/outputs	According to OVDA, galvanic isolation
	Transmission rate	kBaud 125 / 250 / 500
	Transmission protocol	DeviceNet Position Controller Profile
EtherCAT	Signal inputs/outputs	According to IEEE 802.3 standard, no galvanic isolation
	Transmission rate	MBit 100
	Transmission protocol	EtherCAT
Modbus TCP	Signal inputs/outputs	According to IEEE 802.3 standard, no galvanic isolation
	Transmission rate	MBit 10 / 100
	Transmission protocol	Modbus TCP
Ethernet Powerlink	Signal inputs/outputs	According to IEEE 802.3 standard, no galvanic isolation
	Transmission rate	MBit 100
	Transmission protocol	Ethernet Powerlink

(1) Limit values with flanged motor mounted on a steel plate 300 x 300 x 10 mm

(2) Measured at the surface

4

Electrical data		
RS 485 commissioning interface (CN3)		
RS 485	Signal inputs/outputs	According to RS 485, no galvanic isolation, 2-wire
	Transmission rate	kBaud 9.6 / 19.2 / 38.4
	Transmission protocol	Modbus TCP
24 V signal interface (CN4)		
24 V signal inputs		
Galvanically connected to 0VDC, protected against reverse polarity		
Logic 0 (U _{low})	V	-3 ... +4.5
Logic 1 (U _{high})	V	+15 ... +30
Input current (typical at 24 V)	mA	2
Debounce time LIO1 ... LIO4	ms	1.25 ... 1.5
24 V signal outputs		
Switching to plus, short-circuit protected, suitable for inductive load (1000 mH / 100 mA)		
Supply voltage range	V	23 ... 25
Max. switching current (total)	mA	200
Max. switching current per output	mA	100
The internal power supply unit is protected against: ■ Short circuit of the output voltage ■ Overload of output voltage (limited to 6 W output power)		

Interface for safety function "Safe Torque Off" ("Power Removal") (CN5)		
No galvanic isolation; corresponds to RS 485 standard		
Logic 0 (U _{low})	V	-3 ... +4.5
Logic 1 (U _{high})	V	+15 ... +30
Input current (typical at 24 V)	STO_A	mA ≤ 10
	STO_B	mA ≤ 3
Debounce time	ms	1
Response time (until shutdown of power amplifier)	ms	< 50
Max. Time offset until detection of signal differences between STO_A and STO_B	S	< 1

Safety function "Safe Torque Off" ("Power Removal")		
Protection	Of machine	"Safe Torque Off" safety function which forces stopping and/or prevents unintended restarting of the motor, conforming to standard ISO 13849-1, performance level "d" (PL d), and standard IEC/EN 61800-5-2
	Of the system process	"Safe Torque Off" safety function which forces stopping and/or prevents unintended restarting of the motor, conforming to standard IEC/EN 61508 level SIL2 and standard IEC/EN 61800-5-2

Mechanical data of ILE2 without gear					
Type of integrated drive		ILE2●661		ILE2●662	
Nominal supply voltage	V	24	48	24	48
Nominal current	A	6.8	3.8	9.5	7
Nominal speed of rotation	rpm	4800	6000	3100	5000
Nominal output power	W	131	163	162	262
Nominal torque	Nm	0.26		0.5	
Max. torque	Nm	0.43		0.8	
Max. current with power stage disabled	A	0.1			
Detent torque (at zero current)	Nm	0.08		0.106	
Moment of inertia	kg-cm²	0.17		0.34	
Max. speed of rotation	rpm	6500	7000	5000	7000
Positioning resolution per revolution	Inc.	12			
Accuracy of positioning sensor	°	±0.5			
Mass	kg	1.4		1.75	
Shaft load	Max. radial force (1)	N	80		
	Max. axial tensile force	N	30		
	Max. axial force pressure	N	30		
	Nominal bearing service life (2)	h	20000		

(1) Point of application of radial force: 12.5 mm distance to flange
 (2) Operating hours at a probability of failure of 10 %

Mechanical data of ILE2●661 with straight teeth gear

		G1		G2		G3		G4	
Ratio		18:1 (160:9)		38:1 (75:2)		54:1 (490:9)		115:1 (3675:32)	
Number of gear stages		3		3		4		4	
Nominal supply voltage	~ V	24	48	24	48	24	48	24	48
Nominal current	A	6.8	3.8	6.8	3.8	6.8	3.8	6.8	3.8
Nominal speed of rotation of motor	rpm	4000	5000	4000	5000	4000	5000	4000	5000
Nominal output speed of rotation	rpm	225	281	107	133	73	92	35	44
Nominal output torque	Nm	3.5		7,3		10		12	
Nominal output power	W	95	119	95	119	90	112	54	68
Max. current with power stage disabled	A	0.1							
Detent torque (at zero current)	Nm	1.42		3.00		4.36		9.19	
Moment of inertia output	kg·cm ²	48		211		441		1962	
Max. speed of rotation	rpm	281		133		92		44	
Positioning resolution of motor per revolution	Inc.	12							
Positioning accuracy motor	Inc.	±0.5							
Positioning resolution of output	°	1.667		0.8		0.55		0.26	
Torsional backlash	°	≤1							
Mass	kg	1.85							
Shaft load (short-term operation)	Max. radial force (1)	N		200					
	Max. axial force	N		80					
	Nominal bearing service life (2)	h		2500					
Shaft load (long-term operation)	Max. radial force (1)	N		200					
	Max. axial force	N		10					
	Nominal bearing service life (2)	h		15000	15000	15000 (3)	15000 (4)		

Mechanical data of ILE2●661 with worm gear

		G5		G6		G7		G8	
Ratio		24:1 (525:22)		54:1 (1715:32)		92:1 (735:5)		115:1 (3675:32)	
Number of gear stages		2		3		3		3	
Nominal supply voltage	~ V	24	48	24	48	24	48	24	48
Nominal current	A	6.8	3.8	6.8	2.7	6.8	2.6	6.8	2.9
Nominal speed of rotation of motor	rpm	4000	4000	4000	4000	4000	4000	4000	4000
Nominal output speed of rotation	rpm	168		75		44		35	
Nominal output torque	Nm	3.8		6.0		9.2		10.6	
Nominal output power	W	45	66	45	47	41	42	37	39
Max. current with power stage disabled	A	0.1							
Detent torque (at zero current)	Nm	2.9		6.5		12.3		16.7	
Moment of inertia output	kg·cm ²	90		430		1270		1980	
Max. speed of rotation	rpm	186		93		54		44	
Positioning resolution of motor per revolution	Inc.	12							
Positioning accuracy motor	Inc.	±1							
Positioning resolution of output	°	1.26		0.56		0.33		0.26	
Torsional backlash	°	≤ 1.5		≤ 1.0		≤ 1.0		≤ 1.0	
Mass	kg	2.3							
Shaft load	Max. radial force (1)	N		200					
	Max. axial force	N		80					
	Nominal bearing service life (2)	h		3000	6000	9000	9000		

(1) Point of application of radial force: 12.5 mm distance to flange
 (2) Operating hours at a probability of failure of 10%
 (3) With reduced nominal output torque = 6 Nm; 2500 h at maximum torque
 (4) With reduced nominal output torque = 8 Nm; 2500 h at maximum torque

Lexium integrated drives

IL●2 for DeviceNet, EtherCAT, Modbus TCP, Ethernet Powerlink
 ILE2 with brushless DC motor

Torque characteristics ILE2●66

ILE2●661 without gearing

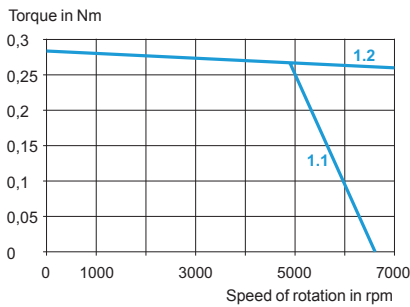

ILE2●661 with straight teeth gear G1

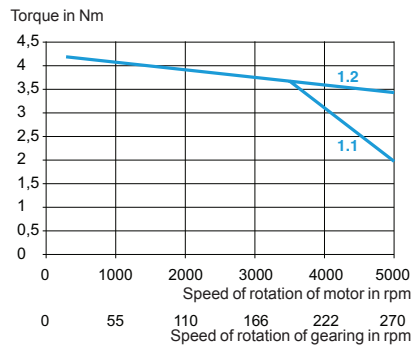

ILE2●661 with worm gear G5

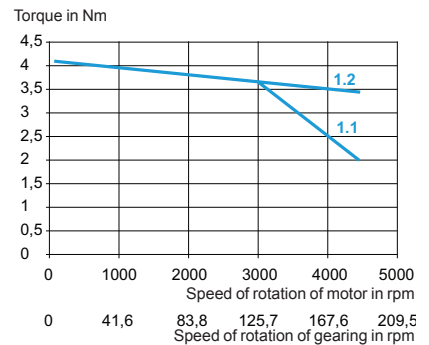

ILE2●662 without gearing

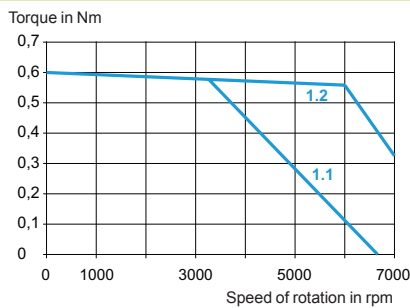

ILE2●661 with straight teeth gear G2

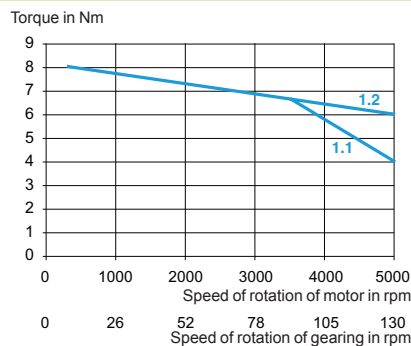

ILE2●661 with worm gear G6

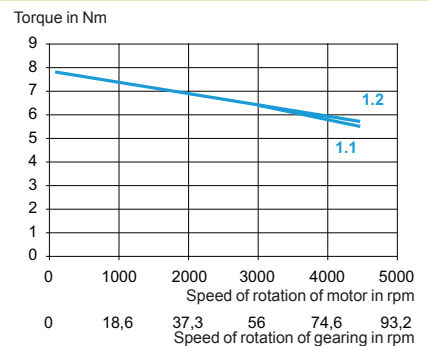

ILE2●661 with straight teeth gear G3

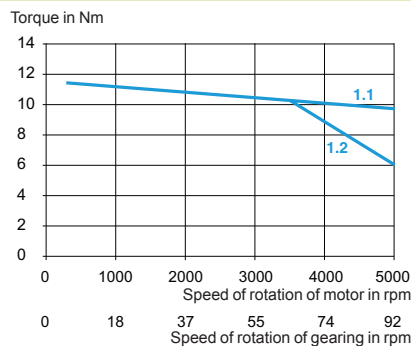

ILE2●661 with worm gear G7

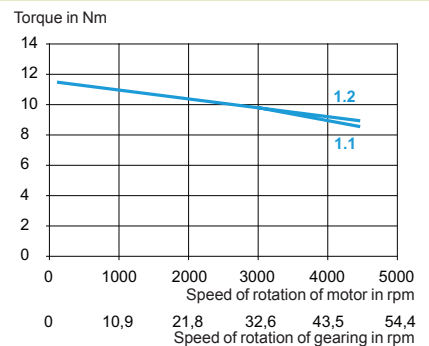

ILE2●661 with straight teeth gear G4

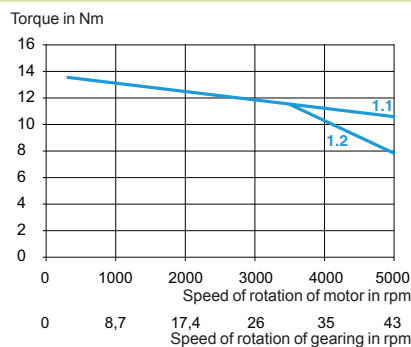

ILE2●661 with worm gear G8

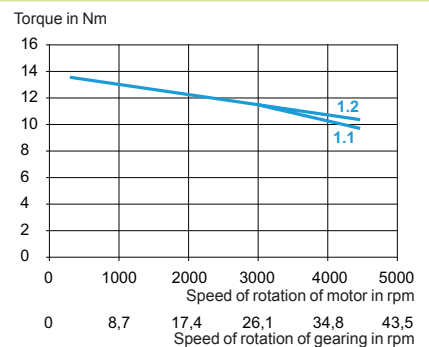

1.1 Max. torque at 24 V
 1.2 Max. torque at 48 V

Lexium integrated drives

IL●2 for DeviceNet, EtherCAT, Modbus TCP,
Ethernet Powerlink
ILE2 with brushless DC motor

References													
Example:	I	L	E	2	D	6	6	1	P	B	1	A	1
Motor type E = brushless DC motor	I	L	E	2	D	6	6	1	P	B	1	A	1
Supply voltage 2 = 24 ... 48 V	I	L	E	2	D	6	6	1	P	B	1	A	1
Communication interface D = DeviceNet E = EtherCAT P = Ethernet Powerlink T = Modbus TCP	I	L	E	2	D	6	6	1	P	B	1	A	1
Flange size 66 = 66 mm	I	L	E	2	D	6	6	1	P	B	1	A	1
Motor length ("L") (1) 1 = motor length ("L") 2 = motor length ("L")	I	L	E	2	D	6	6	1	P	B	1	A	1
Winding type P = medium speed of rotation, medium torque	I	L	E	2	D	6	6	1	P	B	1	A	1
Connection technology B = printed circuit board connector C = industrial connector	I	L	E	2	D	6	6	1	P	B	1	A	1
Measurement system 1 = BLDC encoder	I	L	E	2	D	6	6	1	P	B	1	A	1
Holding brake A = no holding brake	I	L	E	2	D	6	6	1	P	B	1	A	1
Gearing (2) (3) Straight teeth gear 1 = ratio 18:1 (160:9) 2 = ratio 38:1 (75:2) 3 = ratio 54:1 (490:9) 4 = ratio 115:1 (3675:32) Worm gear 5 = ratio 24:1 (525:22) 6 = ratio 54:1 (1715:32) 7 = ratio 92:1 (735:5) 8 = ratio 115:1 (3675:32)	I	L	E	2	D	6	6	1	P	B	1	A	1

(1) The motor length "L" depends on the mechanical characteristics, see pages 4/56, 4/57, 4/60 and 4/61.
 (2) Gearing only with ILE2●661.
 (3) Without gearing: leave out gearing identification in order code (specify 12 characters only).

ILE2 integrated drives without gearing

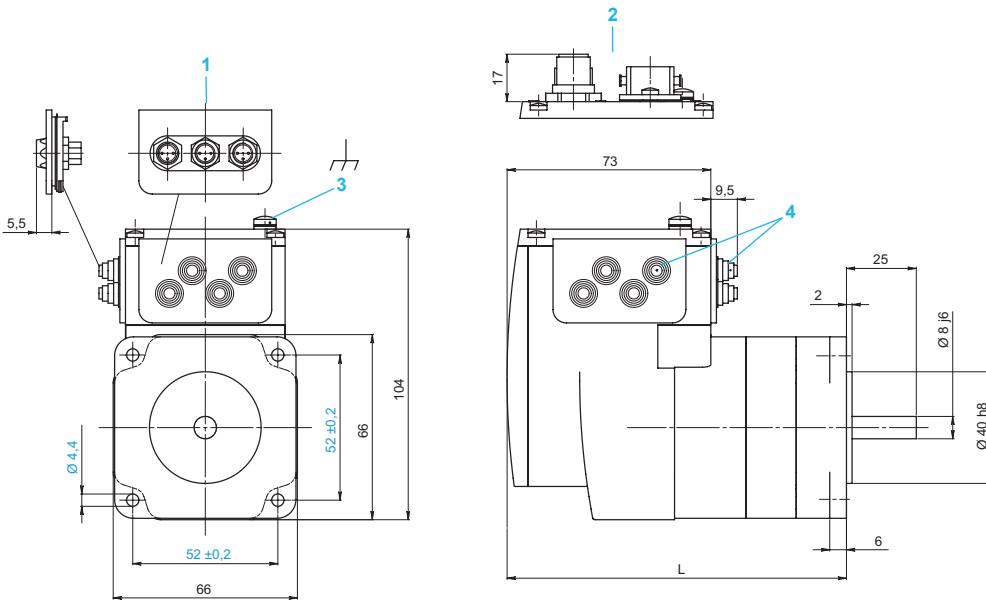

L

ILE2●661	122
ILE2●662	140

- 1 Accessories: I/O signal insert with industrial connectors
- 2 Option: industrial connectors
- 3 Earth (ground) terminal
- 4 Accessories: cable entries $\varnothing = 3 \dots 9$ mm

ILE2 integrated drives with straight teeth gear

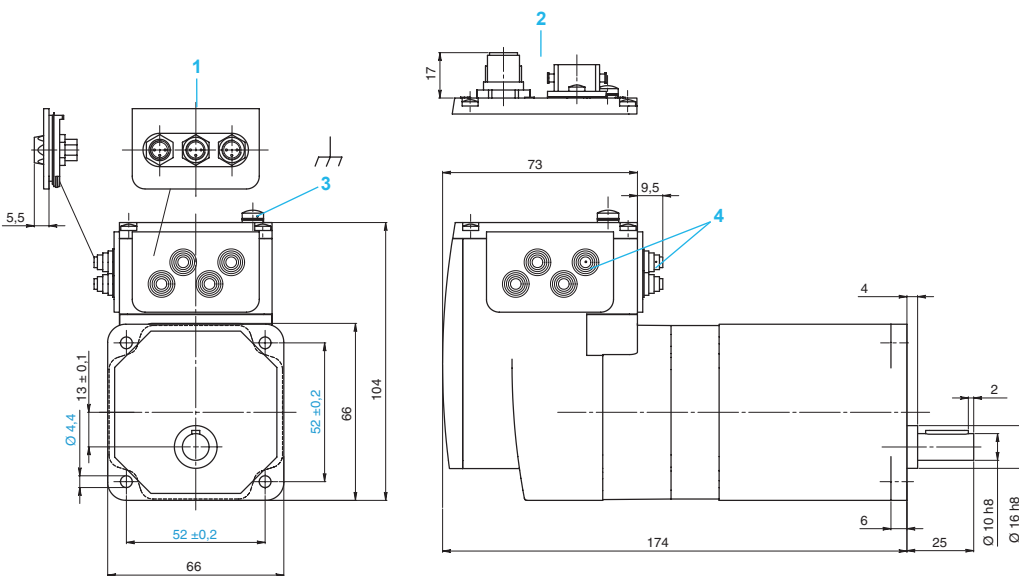

- 1 Accessories: I/O signal insert with industrial connectors
- 2 Option: industrial connectors
- 3 Earth (ground) terminal
- 4 Accessories: cable entries $\varnothing = 3 \dots 9$ mm

ILE2 integrated drives with worm gear

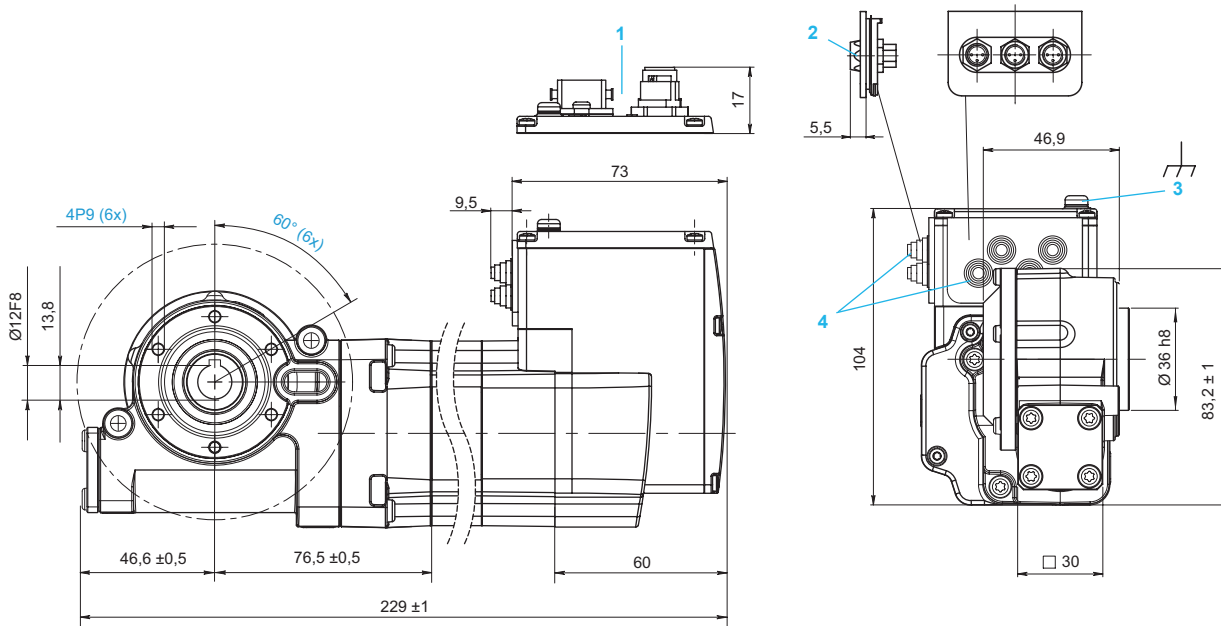

- 1 Accessories: I/O signal insert with industrial connectors
- 2 Option: industrial connectors
- 3 Earth (ground) terminal
- 4 Accessories: cable entries $\varnothing = 3 \dots 9$ mm