

Lifting Column DMD

12, 24 and 36 Vdc - load up to 6800 N



» Ordering Key - see page 69

» Glossary - see page 72

» Electric Wiring Diagram - see page 47

Standard Features and Benefits

- Designed for industrial use
- Rugged, robust and strong
- Self supporting column in extruded anodized aluminum
- Acme or ball screw drive
- High load torque capability
- Overload clutch for mid and end of stroke protection
- T-slot grooves along the entire profile
- Maintenance free

General Specifications

Parameter	DMD
Screw type	acme or ball
Internally restrained	yes
Manual override	no
Dynamic braking	no
Holding brake acme screw models ball screw models	no, self-locking yes
End of stroke protection	overload clutch
Mid stroke protection	overload clutch
Motor protection	auto reset thermal switch
Motor connection	cable
Motor connector	no
Certificates	CE
Options	potentiometer

Performance Specifications

Parameter		DMD
Maximum load, dynamic / static [N]		
DMD •• -05A5 (acme screw)		1100 / 11350
DMD •• -10A5 (acme screw)		2250 / 11350
DMD •• -20A5 (acme screw)		2250 / 11350
DMD •• -05B5 (ball screw)		2250 / 18000
DMD •• -10B5 (ball screw)		4500 / 18000
DMD •• -20B5 (ball screw)		4500 / 18000
DMD •• -21B5 (ball screw)		6800 / 18000
Maximum load torque, dynamic / static [Nm]		
acme screw models		565 / 565
ball screw models		710 / 710
Speed, at no load / at maximum load [mm/s]		
DMD •• -05A5 (acme screw)		54 / 32
DMD •• -10A5 (acme screw)		30 / 18
DMD •• -20A5 (acme screw)		15 / 12
DMD •• -05B5 (ball screw)		61 / 37
DMD •• -10B5 (ball screw)		30 / 19
DMD •• -20B5 (ball screw)		15 / 12
DMD •• -21B5 (ball screw)		15 / 11
Available input voltages [Vdc]		12, 24, 36
Standard stroke lengths [in]		4, 6, 8, 10, 12, 14, 16, 18, 20, 24
Operating temperature limits [°C]		-25 – +65
Full load duty cycle @ 25 °C [%]		25
End play, maximum [mm]		1,0
Restraining torque [Nm]		0
Lead cross section [mm ²]		2,5
Cable length [mm]		2000
Protection class		IP65

Compatible Controls

Control model	See page
DPDT switch	48
DPDT switch box	49
DCG-190	54
AC-063	50

Lifting Column DMD

12, 24 and 36 Vdc - load up to 6800 N

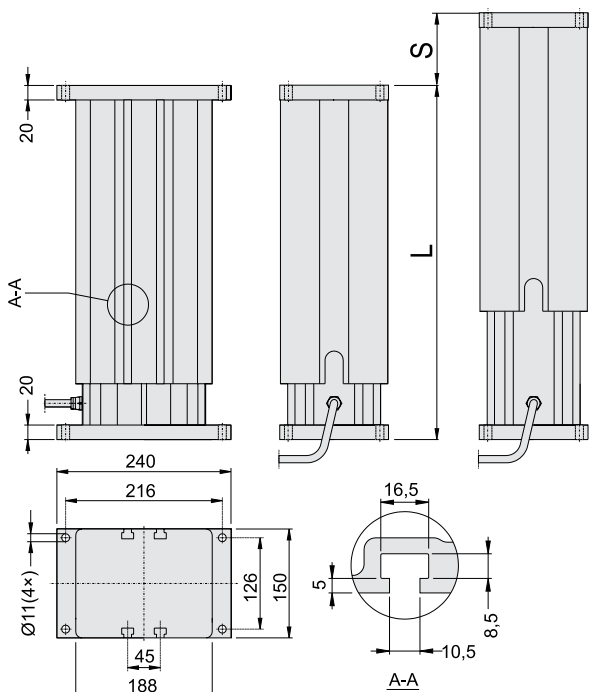

S: stroke L: retracted length

Stroke (S)	[inch (mm)]	4 (101,6)	6 (152,4)	8 (203,2)	10 (254,0)	12 (304,8)	14 (355,6)	16 (406,4)	18 (457,2)	20 (508,0)	24 (609,6)
Retracted length (L), acme screw models	[mm]	329,6	380,4	431,2	482,0	532,8	633,6	684,4	735,2	786,0	887,6
Retracted length (L), ball screw models	[mm]	369,6	420,4	471,2	522,0	572,8	673,6	724,4	775,2	826,0	927,6
Add on length for potentiometer*	[mm]	55,0	55,0	55,0	55,0	55,0	55,0	55,0	55,0	55,0	55,0
Weight, acme screw models	[kg]	18,7	20,2	21,6	23,1	24,6	27,3	28,7	30,2	31,7	34,6
Weight, ball screw models	[kg]	20,4	21,9	23,4	24,8	26,3	29,0	30,4	31,9	33,4	36,3
Add on weight for potentiometer*	[kg]	1,3	1,3	1,3	1,3	1,3	1,3	1,3	1,3	1,3	1,3

* Potentiometer is optional

Off Center Load Capacity

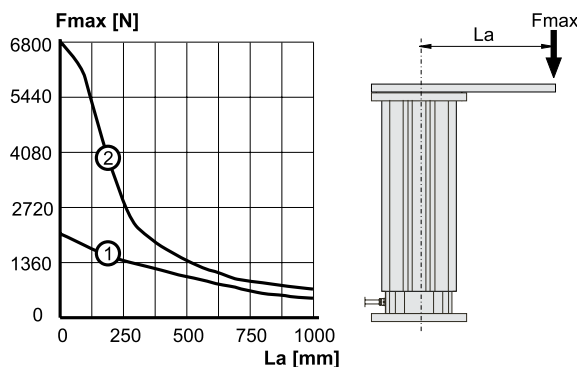

F_{max} : maximum load operated L_a : length of lever arm

1: acme screw models
2: ball screw models

Performance Diagrams

Speed and Current vs. Load - Chart 1

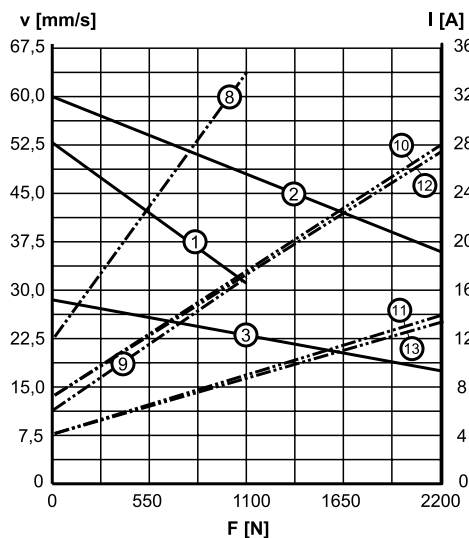

Speed and Current vs. Load - Chart 2

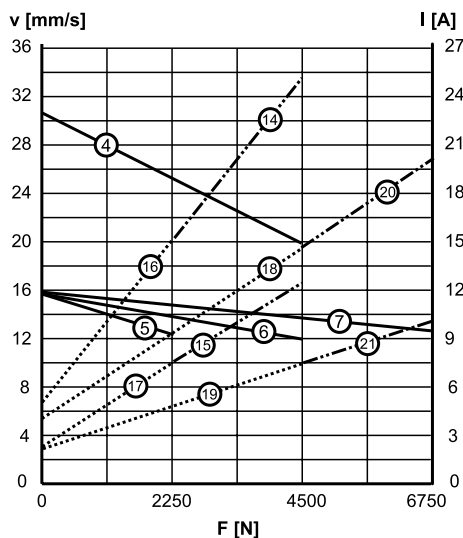

V: speed I: current F: load

- 1: speed DMD ••-05A5 - chart 1
- 2: speed DMD ••-05B5 - chart 1
- 3: speed DMD ••-10A5 - chart 1
- 4: speed DMD ••-10B5 - chart 2
- 5: speed DMD ••-20A5 - chart 2
- 6: speed DMD ••-20B5 - chart 2
- 7: speed DMD ••-21B5 - chart 2
- 8: current DMD12-05A5 - chart 1
- 9: current DMD24-05A5 - chart 1
- 10: current DMD12-05B5 - chart 1
- 11: current DMD24-05B5 - chart 1
- 12: current DMD12-10A5 - chart 1
- 13: current DMD24-10A5 - chart 1
- 14: current DMD12-10B5 - chart 2
- 15: current DMD24-10B5 - chart 2
- 16: current DMD12-20A5 - chart 2
- 17: current DMD24-20A5 - chart 2
- 18: current DMD12-20B5 - chart 2
- 19: current DMD24-20B5 - chart 2
- 20: current DMD12-21B5 - chart 2
- 21: current DMD24-21B5 - chart 2

Contact customer service for data on 36 Vdc models.

Lifting Column DMA

230 and 400 Vac - load up to 6800 N

» Ordering Key - see page 69

» Glossary - see page 72

» Electric Wiring Diagram - see page 47



Standard Features and Benefits

- Designed for industrial use
- Rugged, robust and strong
- Self supporting column in extruded anodized aluminum
- Acme or ball screw drive
- High load torque capability
- Overload clutch for mid and end of stroke protection
- T-slot grooves along the entire profile
- Maintenance free

General Specifications

Parameter	DMA
Screw type	acme or ball
Internally restrained	yes
Manual override	no
Dynamic braking	no
Holding brake acme screw models ball screw models	no, self-locking yes
End of stroke protection	overload clutch
Mid stroke protection	overload clutch
Motor protection	auto reset thermal switch
Motor connection	cable
Motor connector	no
Certificates	CE
Options	potentiometer

Performance Specifications

Parameter	DMA
Maximum load, dynamic / static [N] DMA22-05A5 (acme screw)* DMA •• -10A5 (acme screw) DMA •• -20A5 (acme screw) DMA •• -05B5 (ball screw) DMA •• -10B5 (ball screw) DMA •• -20B5 (ball screw) DMA •• -21B5 (ball screw)	1100 / 11350 2250 / 11350 2250 / 11350 2250 / 18000 4500 / 18000 4500 / 18000 6800 / 18000
Maximum load torque, dynamic / static [Nm] acme screw models ball screw models	565 / 565 710 / 710
Speed, at no load / at maximum load [mm/s] DMA22-05A5 (acme screw)* DMA •• -10A5 (acme screw) DMA •• -20A5 (acme screw) DMA •• -05B5 (ball screw) DMA •• -10B5 (ball screw) DMA •• -20B5 (ball screw) DMA •• -21B5 (ball screw)	48 / 38 30 / 18 15 / 12 61 / 37 30 / 19 15 / 12 15 / 11
Available input voltages [Vac] Single phase** Three phase	230 400
Input frequency [Hz] 1 × 230 Vac model 3 × 400 Vac model	50/60 50
Standard stroke lengths [in]	4, 6, 8, 10, 12, 14, 16, 18, 20, 24
Operating temperature limits [°C]	-25 – +65
Maximum on time [s]	45
Full load duty cycle @ 25 °C [%]	25
End play, maximum [mm]	1,0
Restraining torque [Nm]	0
Lead cross section [mm ²]	2,5
Cable length [mm]	2000
Protection class	IP45

* Not possible with 400 Vac input voltage

** 10 µF capacitor required to run the actuator, p/n 9200-448-003

Compatible Controls

Control model	See page
DPDT switch	48
DPDT switch box	49

Lifting Column DMA

230 and 400 Vac - load up to 6800 N

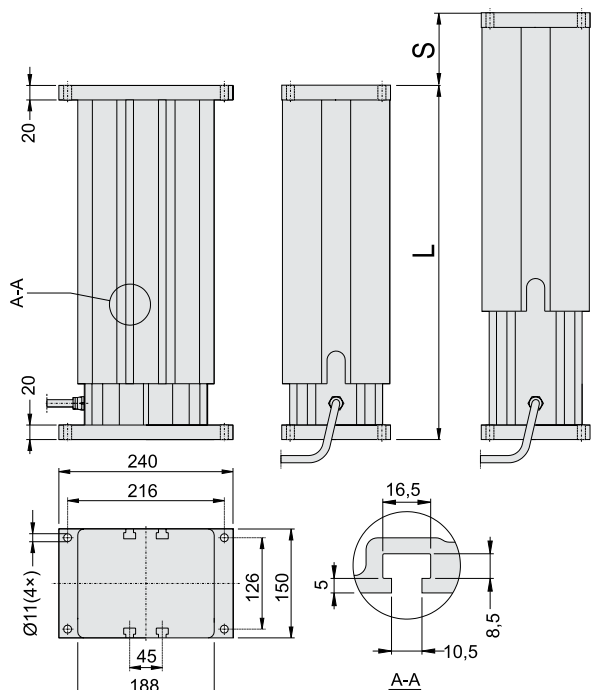

S: stroke L: retracted length

Off Center Load Capacity

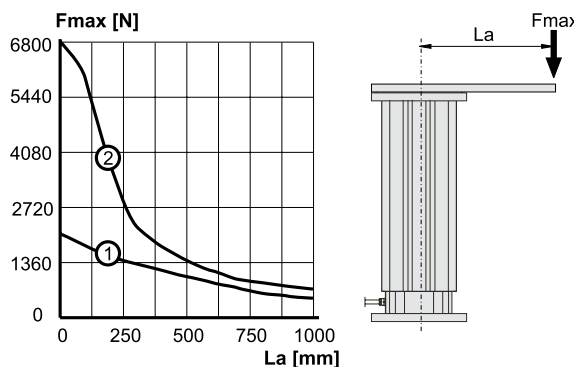

Fmax: maximum load operated La: length of lever arm

1: acme screw models
2: ball screw models

Stroke (S)	[inch (mm)]	4 (101,6)	6 (152,4)	8 (203,2)	10 (254,0)	12 (304,8)	14 (355,6)	16 (406,4)	18 (457,2)	20 (508,0)	24 (609,6)
Retracted length (L), acme screw models	[mm]	329,6	380,4	431,2	482,0	532,8	633,6	684,4	735,2	786,0	887,6
Retracted length (L), ball screw models	[mm]	369,6	420,4	471,2	522,0	572,8	673,6	724,4	775,2	826,0	927,6
Add on length for potentiometer*	[mm]	55,0	55,0	55,0	55,0	55,0	55,0	55,0	55,0	55,0	55,0
Weight, acme screw models	[kg]	20,9	22,4	23,8	25,3	26,8	29,5	30,9	32,4	33,9	36,8
Weight, ball screw models	[kg]	22,6	24,1	25,6	27,0	28,5	31,2	32,6	34,1	35,6	38,6
Add on weight for potentiometer*	[kg]	1,3	1,3	1,3	1,3	1,3	1,3	1,3	1,3	1,3	1,3

* Potentiometer is optional

Performance Diagrams

Speed and Current vs. Load - Chart 1

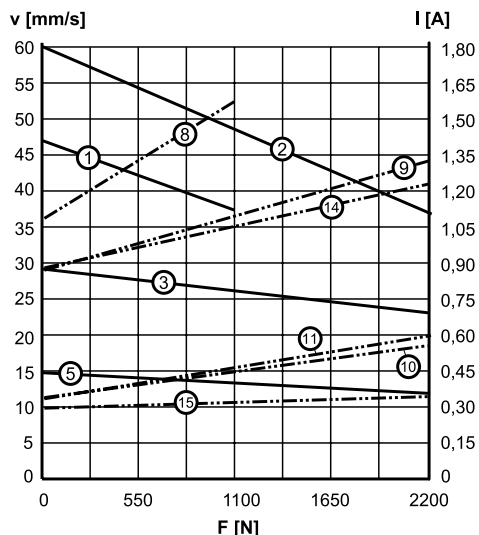

Speed and Current vs. Load - Chart 2

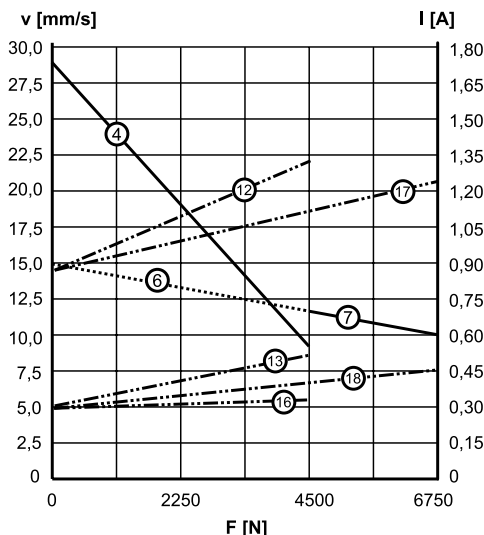

V: speed I: current F: load

- 1: speed DMA22-05A5 - chart 1
- 2: speed DMA 05B5 - chart 1
- 3: speed DMA 10A5 - chart 1
- 4: speed DMA 10B5 - chart 2
- 5: speed DMA 20A5 - chart 1
- 6: speed DMA 20B5 - chart 2
- 7: speed DMA 21B5 - chart 2
- 8: current DMA22-05A5 - chart 1
- 9: current DMA22-05B5 and DMA22-10A5 - chart 1
- 10: current DMA42-05B5 - chart 1
- 11: current DMA42-10A5 - chart 1
- 12: current DMA22-10B5 and DMA22-20B5 - chart 2
- 13: current DMA42-10B5 - chart 2
- 14: current DMA22-20A5 - chart 1
- 15: current DMA42-20A5 - chart 1
- 16: current DMA42-20B5 - chart 2
- 17: current DMA22-21B5 - chart 2
- 18: current DMA42-21B5 - chart 2

Ordering Keys

Lifting Columns

DMD			
1	2	3	4
DMD24 -	10B5 -	16	PO
1. Model and input voltage DMD12 - = DMD, 12 Vdc DMD24 - = DMD, 24 Vdc DMD36 - = DMD, 36 Vdc	2. Dynamic load capacity, screw type and maximum speed 05A5 = 1100 N, acme, 54 mm/s 10A5 = 2250 N, acme, 30 mm/s 20A5 = 2250 N, acme, 15 mm/s 05B5 = 2250 N, ball, 61 mm/s 10B5 = 4500 N, ball, 30 mm/s 20B5 = 4500 N, ball, 15 mm/s 21B5 = 6800 N, ball, 15 mm/s	3. Stroke 04 = 4 inch (101,6 mm) 06 = 6 inch (152,4 mm) 08 = 8 inch (203,2 mm) 10 = 10 inch (254,0 mm) 12 = 12 inch (304,8 mm) 14 = 14 inch (355,6 mm) 16 = 16 inch (406,4 mm) 18 = 18 inch (457,2 mm) 20 = 20 inch (508,0 mm) 24 = 24 inch (609,6 mm)	4. Options¹ PO = potentiometer ¹ Leave position blank for no option.

DMA			
1	2	3	4
DMA22 -	20A5 -	06	
1. Model and input voltage DMA22 - = DMA, 1 × 230 Vac DMA42 - = DMA, 3 × 400 Vac	2. Dynamic load capacity, screw type and maximum speed 05A5 = 1100 N, acme, 54 mm/s ¹ 10A5 = 2250 N, acme, 30 mm/s 20A5 = 2250 N, acme, 15 mm/s 05B5 = 2250 N, ball, 61 mm/s 10B5 = 4500 N, ball, 30 mm/s 20B5 = 4500 N, ball, 15 mm/s 21B5 = 6800 N, ball, 15 mm/s	3. Stroke 04 = 4 inch (101,6 mm) 06 = 6 inch (152,4 mm) 08 = 8 inch (203,2 mm) 10 = 10 inch (254,0 mm) 12 = 12 inch (304,8 mm) 14 = 14 inch (355,6 mm) 16 = 16 inch (406,4 mm) 18 = 18 inch (457,2 mm) 20 = 20 inch (508,0 mm) 24 = 24 inch (609,6 mm)	4. Options² PO = potentiometer ¹ 05A5 not possible with 400 Vac input voltage. ² Leave position blank for no option.